

Resource
Data Management

Intuitive Mercury Thermostat & Humidistat

Installation & User Guide
Revision 3.1



PR0440

Contents

The Mercury Intuitive Range	4
Types.....	4
Type 1: Triple thermostat with timer.....	4
Type 2: Temperature and Humidity thermostat with timer	4
Compatible Network Interfaces	4
Display Features.....	4
Display	5
Enter Button	5
Up Button	5
Down Button.....	5
# Button	5
Icons	5
Display Connection	5
Connections.....	6
Intuitive Mercury Controller	6
Ordering Information	6
Input / Output allocation table	7
Type 1 Triple Thermostat.....	7
Type 2 Thermostat/ Humidistat	7
Setting up the controller.....	7
Setup through the display buttons	7
Setup Function Menu	8
Recommended set-up method.....	8
RTC - Real time clock	8
Type - Set/view controller type	8
Unit - Set/view temperature unit and Probe type	8
PARA - Set/view parameters	9
Parameter Tables	9
Parameter Table for Type 1 - Triple Thermostat.....	9
Parameter Table for Type 2 - Temperature and Humidity Thermostat with timer....	11
Net - Network Configuration	13
Network Options.....	13
IP-L	13
IP-r.....	13
Bluetooth Network module.....	14
IO - Viewing Inputs & Outputs	14
Input / Output Table – Type 1 - Triple Thermostat.....	14
Input / Output Table - Type 2 - Temperature and Humidity Thermostat with timer	15
OFSt - Probe Offset.....	15
Display Messages	15
Network Alarms.....	15
Faults	16
GP Timer Set-up.....	16
Operation:.....	16
Type 1: Triple Thermostat	16
Type 2: Temp and Humidity Thermostat with timer.....	16
Frost Detect.....	17
Set point Adjustment from Display.....	17
Cooling Thermostat graph.....	17
Heating Thermostat graph	17
Specification	18
Installation	19
Mounting Instructions - Intuitive.....	20
Mounting Instructions - Display	20



Please ensure all power is switched off before installing or maintaining this product.

Cleaning	21
Disclaimer	21
Appendix 1 Comfort Index.....	21
Revision History	22



Please ensure all power is switched off before installing or maintaining this product.

The Mercury Intuitive Range

From Resource Data Management

For Version 3.0, applies only to products manufactured after August 2019.

Types

There are 2 types of controller embedded in the Humidistat controller:

Display value	Type
1	Triple Thermostat with Timer
2	Temp and Humidity Thermostat with timer

Type 1: Triple thermostat with timer

This controller has 3 thermostat functions. They can be independent, using a separate probe for each function, or the controller can be configured for a three stage thermostat using a single probe. There is a 7 day timer with 2 on and 2 off times per day. The humidity value for all options can be for monitoring or be used as part of the thermostat function (effective temperature). The set-point range can be limited to prevent the user increasing/ decreasing the temperature by too much.

Type 2: Temperature and Humidity thermostat with timer

This controller has a temperature thermostat function and a humidistat function using a humidity sensor. There is a 7 day timer with 2 on times and 2 off times per day.

Compatible Network Interfaces

The Intuitive Mercury Thermostat & Humidistat has a built-in Ethernet interface and is capable of connecting to a TCP/IP local area network.

Display Features

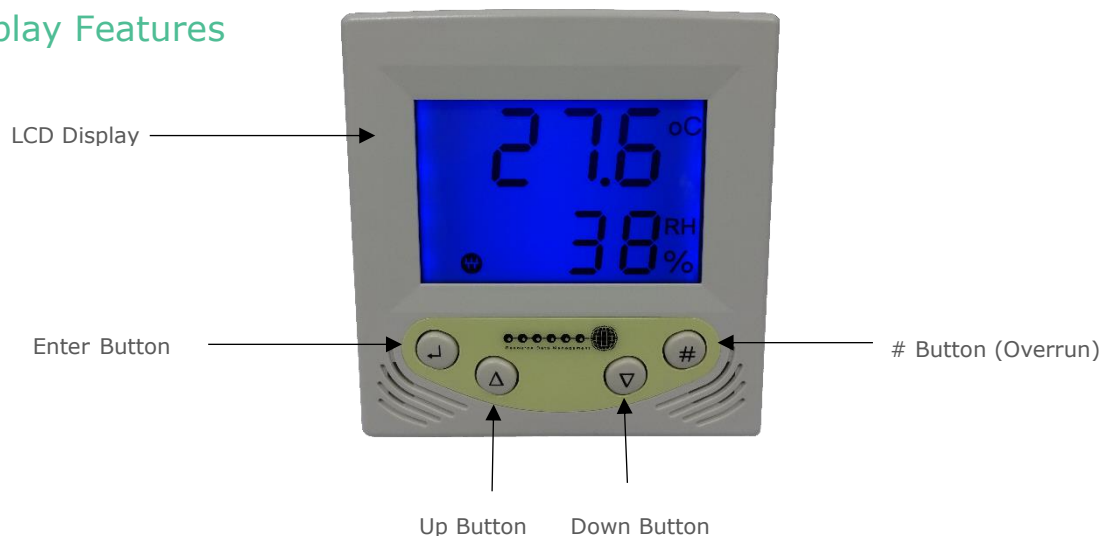

Note: The maximum cable length is 5 meters.



Please ensure all power is switched off before installing or maintaining this product.

Display

The display will show the current values of the temperature and humidity. The display has an integrated temperature probe and humidity sensor. The backlight will stay illuminated for 2 minutes after last user interaction.

Enter Button

Button used to enter values after a change.

Up Button

Normally the up button will increment the set point. When in the menu, the up button is used to scroll up through the menu items.

Down Button

Normally the down button will decrement the set point. When in the menu, the down button is used to scroll down through the menu items

Button

Overrun function. Use this button to provide up to 6 hours of 'on' time, if the timer is off, or if the timer is on, extend its time by up to 6 hours. The overrun function will switch off the amber LED if it's on, or keep it off for the extra hours. Press and hold the # button until 'run 0' appears. Use the up button to select between a run on of 1 to 6 hours. Press the enter button to confirm the desired run on hours.

Press the # button during an overrun period to cancel the overrun and turn the relay(s) off.

Icons

Network



- Off No network attached
- Flashing Attempting to Log on to network
- Steady On-line

Alarm



The alarm bell icon is used to indicate a probe fault or alarm.

Time



The defrost Icon indicates the current state of the Timer. If the icon is off, the Timer is in the 'on' state. If the icon is on, the Timer is in the 'off' state.

Display Connection

Controller	Display
SDO (Serial Data Out)	Data In
SCL (Serial Clock)	Clock
GND	GND
SDI (Serial Data In)	Data Out
+5V (Vdc)	Vdc



Please ensure all power is switched off before installing or maintaining this product.

Connections

Intuitive Mercury Controller

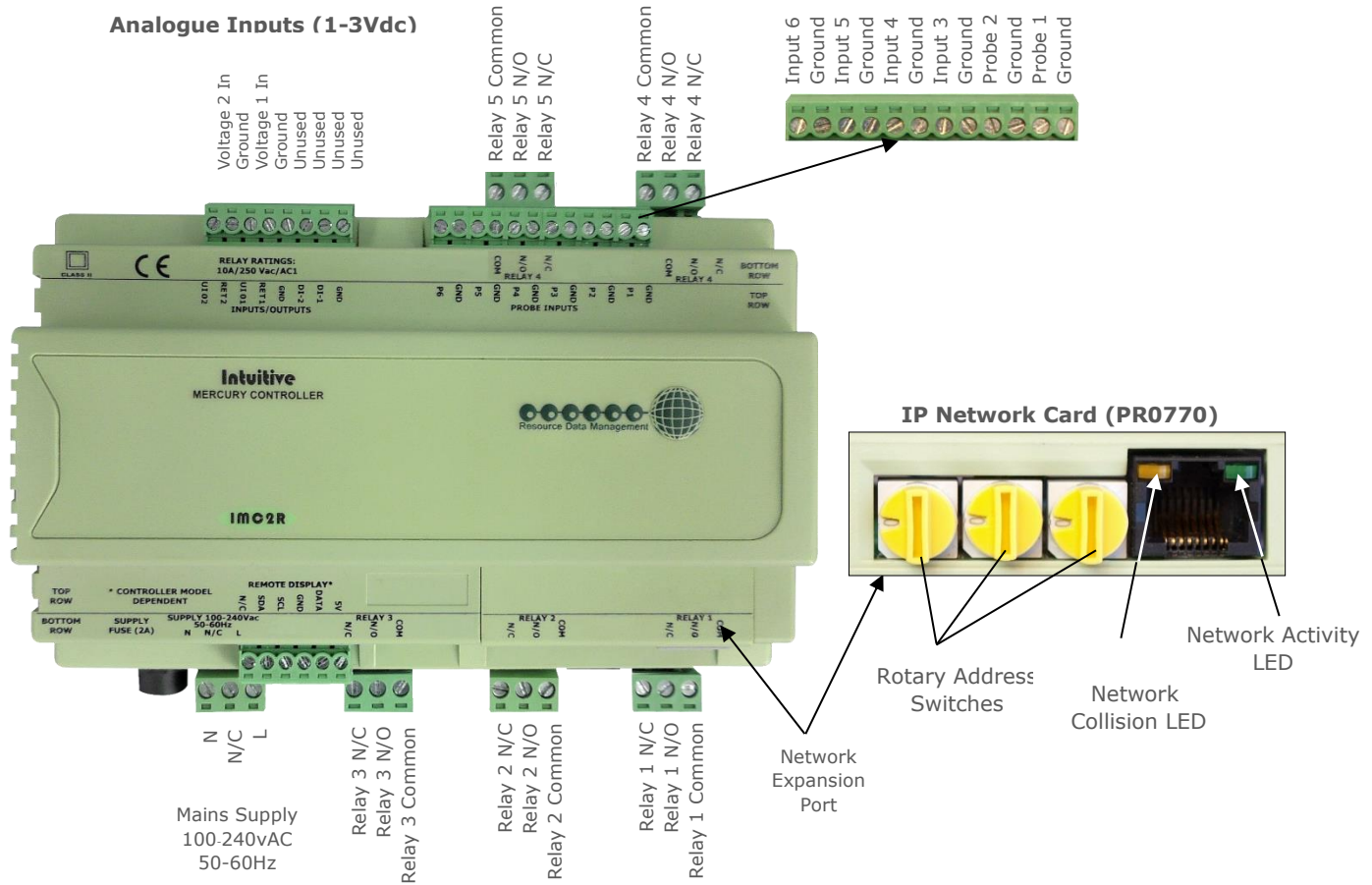

Note: N/C in supply connection is 'No Connection'.

No earth connection required.

All inputs and outputs are plug and socket. The supply voltage and each relay output have individual fuse protection.

Ordering Information

Description	Part Number
Intuitive 3 Relay Humidity Stat with Display & 5m Display Cable	PR0440
Intuitive 3 Relay Humidity Stat with Display & 5m Display Cable - Non Fused	PR0440 NF
Humidity / Temperature Display with 5m Display Cable	PR0445



Please ensure all power is switched off before installing or maintaining this product.

Input / Output allocation table

Type 1 Triple Thermostat

Input/output	Description	Alarm Action
Display Temperature	Fixed Sensor in the display	yes
Display Humidity	Fixed sensor in the display	yes
Voltage 1 Input	Humidity sensor	yes
Voltage 2 Input	Humidity sensor	yes
Probe Input 1	Temperature Probe	yes
Probe Input 2	Temperature Probe	yes
Probe Input 3	Temperature Probe	yes
Probe Input 4	Temperature Probe	yes
Relay 1	Stat A control	N/A
Relay 2	Stat B control	N/A
Relay 3	Stat C control	N/A
Relay 4	Timer Relay	N/A
Relay 5	Alarm Relay	N/A

Type 2 Thermostat / Humidistat

Input/output	Description	Alarm Action
Display Temperature	Fixed Sensor in the display	yes
Display Humidity	Fixed sensor in the display	yes
Voltage 1 Input	Humidity sensor	yes
Voltage 2 Input	Humidity sensor	yes
Probe Input 1	Temperature Probe	yes
Probe Input 2	Temperature Probe	yes
Probe Input 3	Temperature Probe	yes
Probe Input 4	Temperature Probe	yes
Relay 1	Thermostat control	N/A
Relay 2	Humidistat control	N/A
Relay 3	Not used	N/A
Relay 4	Timer relay	N/A
Relay 5	Alarm Relay	N/A

Note: This product has been designed to drive contactors with coil currents of less than 2 Amps at 230 Vac. It must **NOT** be used to switch the heaters directly unless they have an inductive load rating of less than 2A.

Setting up the controller

Access to the controller can be achieved through several methods

- Through the RDM Data Manager.
- Across an IP network or directly through the controllers built in IP interface (current controller IP address required)

Setup through the display buttons

To enter setup mode, hold the Enter and Down buttons together for approximately 3 seconds until the message "Ent" appears on the display. Now press the Enter button again to enter the function menu. IO will be displayed. Scroll up or down to go through the list.



Please ensure all power is switched off before installing or maintaining this product.

Setup Function Menu

Display	Option	Explained in Paragraph	Display	Option	Explained in Paragraph
IO	View Inputs / Outputs and States	Input / output table	nEt	Set/view network configuration	Network Configuration
PArA	Set/View Parameters	Set view parameters	SoFt	View software version	
Unit	Probe type and Celsius/Fahrenheit option	Set View Unit	OFSt	Probe Offset	Probe Offset
tyPE	Set/View Controller Type	Set/view controller type	ESC	Exit Setup mode	
rtc	Set/view Clock (rtc = Real Time Clock)	Real Time Clock			

Recommended set-up method

If you are not connecting to a network and want to set up the controller through the buttons we recommend you use the following order from the function menu.

RTC - Real time clock

(This will automatically synchronise on networked systems)

- Use the up or down buttons to scroll through the display until the display reads "rtc"
- Press enter. The display will show "t-1". press enter again
- Scroll hours up or down (0 – 23) press enter
- Use up button to select "t-2", press enter
- Scroll minutes up or down (0 – 59) press enter
- Repeat for t-3 (seconds 0 – 59)
- Repeat for t -4 (days up to 31)
- Repeat for t -5 (months up to 12)
- Repeat for t -6 (year up to 99)
- Use up button to display "ESC", press enter to display "rtc"

Controller time clock is now set

Type - Set/view controller type

- From the function menu scroll to select type, press enter
- Use the up/down buttons to scroll to configuration types 1 or 2
- Press enter.
- Scroll to select "ESC"
- Press enter

Controller type clock is now set

Unit - Set/view temperature unit and Probe type

Scroll through the function menu and select 'Unit'. Pressing enter, the current probe type will be displayed;

0 for PT1000 Celsius	10 for NTC2K25 Celsius
1 for PT1000 Fahrenheit	11 for NTC2K25 Fahrenheit
2 for NTC2K Celsius	12 for 5K Celsius
3 for NTC2K Fahrenheit	13 for 5K Fahrenheit
4 for 470R Celsius	14 for 6K Celsius
5 for 470R Fahrenheit	15 for 6K Fahrenheit
6 for 700R Celsius	16 for NTC10K Celsius
7 for 700R Fahrenheit	17 for NTC10K Fahrenheit
8 for 3K Celsius	18 for NTC10K(2) Celsius (USA NTC10K)
9 for 3K Fahrenheit	19 for NTC10K(2) Fahrenheit (USA NTC10K)

Use the up or down keys to select the desired units and press enter. This function is now complete



Please ensure all power is switched off before installing or maintaining this product.

PArA - Set/view parameters

(This can also be achieved at the network front end)

- From the function menu scroll to and select "PArA".
- Pressing the Enter button while "PArA" is displayed will enter the parameter menu. The first parameter option will be displayed as P-01. Pressing the Up or Down button will present the other parameter options P-02, P-03 etc. See the parameter list below to find what parameter number corresponds to the associated parameter.
- Pressing the Enter button will show the current value of the selected parameter. Press Up or Down to modify the value and press Enter again to save the value. The parameter list number will be displayed again. Two other options are present in the parameter menu – dFLt and ESC. Selecting ESC will exit setup mode. Selecting dFLt will reset all parameters back to the default values for the current controller type.

Parameter Tables

Parameter Table for Type 1 - Triple Thermostat

Number	Parameter	Range °C (°F)	Step	Units	Def. °C (°F)
P01	Stat A set point	-42 to 60 (-43 to 140)	0.1	°C (°F)	15 (59)
P02	Stat A diff	-42 to 60 (-43 to 140)	0.1	°C (°F)	5 (41)
P03	Stat A Input	0 = Off 1 = Display Probe 2 = Probe 1 3 = Probe 2 4 = Probe 3 5 = Probe 4	1		1
P04	Stat A type	0 = Cooling 1 = Heating	1		1
P05	Stat A min set	0 to 60 (32 to 140)	0.1	°C (°F)	5 (10)
P06	Stat A max set	0 to 60 (32 to 140)	0.1	°C (°F)	5 (10)
P07	Stat A Comfort Index	0 = No 1 = Display Sensor 2 = Sensor 1 3 = Sensor 2	1		0
P21	Stat B set point	-42 to 60 (-43 to 140)	0.1	°C (°F)	18 (65)
P22	Stat B diff	-42 to 60 (-43 to 140)	0.1	°C (°F)	5 (41)
P23	Stat B Input	0 = Off 1 = Display probe 2 = Probe 1 3 = Probe 2 4 = Probe 3 5 = Probe 4	1		1
P24	Stat B type	0 = Cooling 1 = Heating	1		1
P25	Stat B min set	0 to 60 (32 to 140)	0.1	°C (°F)	5 (10)
P26	Stat B max set	0 to 60 (32 to 140)	0.1	°C (°F)	5 (10)
P27	Stat B Comfort Index	0 = No 1 = Display Sensor 2 = Sensor 1 3 = Sensor 2	1		0
P40	Stat C set point	-42 to 60 (-43 to 140)	0.1	°C (°F)	20 (68)
P41	Stat C diff	-42 to 60 (-43 to 140)	0.1	°C (°F)	5 (41)
P43	Stat C Input	0 = Off 1 = Display probe 2 = Probe 1 3 = Probe 2 4 = Probe 3 5 = Probe 4	1		0
P44	Stat C type	0 = Cooling 1 = Heating	1		1



Please ensure all power is switched off before installing or maintaining this product.

Number	Parameter	Range °C (°F)	Step	Units	Def. °C (°F)
P45	Stat C min set	0 to 60 (32 to 140)	0.1	°C (°F)	5 (10)
P46	Stat C max set	0 to 60 (32 to 140)	0.1	°C (°F)	5 (10)
P47	Stat C Comfort Index	0 = No 1 = Display Sensor 2 = Sensor 1 3 = Sensor 2	1		0
P60	Display	0 = Cycle 1 = Stat A 2 = Stat B 3 = Stat C 4 = Stat A & Stat B 5 = Stat A & Stat C 6 = Stat B & Stat C	1		0
P61	Frost probe select	0 = Off 1 = Display probe 2 = Probe 1 3 = Probe 2 4 = Probe 3 5 = Probe 4	1		0
P62	Frost Detect	-59 to 128 (-74 to 262)	0.1	°C (°F)	0 (32)
P63	Frost Cut In	-42 to 60 (-43 to 140)	0.1	°C (°F)	10 (50)
P64	Display Offset	-10 to 10	0.1	°C (°F)	0 (32)
P10	Stat A High Alarm	-59 to 128 (-74 to 262)	0.1	°C (°F)	25 (77)
P11	Stat A Low Alarm	-59 to 128 (-74 to 262)	0.1	°C (°F)	-5 (23)
P12	Stat A Alarm Delay	00 to 99	1	mins	20
P30	Stat B High Alarm	-59 to 128 (-74 to 262)	0.1	°C (°F)	25 (77)
P31	Stat B Low Alarm	-59 to 128 (-74 to 262)	0.1	°C (°F)	-5 (23)
P32	Stat B Alarm Delay	00 to 99	1	mins	20
P50	Stat C High Alarm	-59 to 128 (-74 to 262)	0.1	°C (°F)	25 (77)
P51	Stat C Low Alarm	-59 to 128 (-74 to 262)	0.1	°C (°F)	-5 (23)
P52	Stat C Alarm Delay	00 to 99	1	mins	20
P70	Timer Mode	0 = local 1 = Remote 2 = Force Off 3 = Force On	1		0
P71	Sunday On Time 1	00:00 to 23:59	00:01	hr:min	08:00
P72	Sunday Off Time 1	00:00 to 23:59	00:01	hr:min	20:00
P73	Sunday On Time 2	00:00 to 23:59	00:01	hr:min	08:00
P74	Sunday Off Time 2	00:00 to 23:59	00:01	hr:min	20:00
P75	Monday On Time 1	00:00 to 23:59	00:01	hr:min	08:00
P76	Monday Off Time 1	00:00 to 23:59	00:01	hr:min	20:00
P77	Monday On Time 2	00:00 to 23:59	00:01	hr:min	08:00
P78	Monday Off Time 2	00:00 to 23:59	00:01	hr:min	20:00
P79	Tuesday On Time 1	00:00 to 23:59	00:01	hr:min	08:00
P80	Tuesday Off Time 1	00:00 to 23:59	00:01	hr:min	20:00
P81	Tuesday On Time 2	00:00 to 23:59	00:01	hr:min	08:00
P82	Tuesday Off Time 2	00:00 to 23:59	00:01	hr:min	20:00
P83	Wednesday On Time 1	00:00 to 23:59	00:01	hr:min	08:00
P84	Wednesday Off Time 1	00:00 to 23:59	00:01	hr:min	20:00
P85	Wednesday On Time 2	00:00 to 23:59	00:01	hr:min	08:00
P86	Wednesday Off Time 2	00:00 to 23:59	00:01	hr:min	20:00
P87	Thursday On Time 1	00:00 to 23:59	00:01	hr:min	08:00
P88	Thursday Off Time 1	00:00 to 23:59	00:01	hr:min	20:00
P89	Thursday On Time 2	00:00 to 23:59	00:01	hr:min	08:00
P90	Thursday Off Time 2	00:00 to 23:59	00:01	hr:min	20:00
P91	Friday On Time 1	00:00 to 23:59	00:01	hr:min	08:00
P92	Friday Off Time 1	00:00 to 23:59	00:01	hr:min	20:00



Please ensure all power is switched off before installing or maintaining this product.

Number	Parameter	Range °C (°F)	Step	Units	Def. °C (°F)
P93	Friday On Time 2	00:00 to 23:59	00:01	hr:min	08:00
P94	Friday Off Time 2	00:00 to 23:59	00:01	hr:min	20:00
P95	Saturday On Time 1	00:00 to 23:59	00:01	hr:min	08:00
P96	Saturday Off Time 1	00:00 to 23:59	00:01	hr:min	20:00
P97	Saturday On Time 2	00:00 to 23:59	00:01	hr:min	08:00
P98	Saturday Off Time 2	00:00 to 23:59	00:01	hr:min	20:00
dFLt	Restore defaults				

Parameter Table for Type 2 - Temperature and Humidity Thermostat with timer

Number	Parameter	Range °C (°F)	Step	Units	Def. °C (°F)
P01	Temp Stat set point	-42 to 60 (-43 to 140)	0.1	°C (°F)	15 (59)
P02	Temp Stat diff	-42 to 60 (-43 to 140)	0.1	°C (°F)	5 (41)
P03	Temp Stat Probe select	0 = None 1 = Display probe 2 = Probe 1 3 = Probe 2 4 = Probe 3 5 = Probe 4	1		1
P04	Temp Stat type	0 = Cooling 1 = Heating	1		1
P05	Temp Stat min set	0 to 60 (32 to 140)	0.1	°C (°F)	5 (10)
P06	Temp Stat max set	0 to 60 (32 to 140)	0.1	°C (°F)	5 (10)
P07	Stat Comfort Index	0 = None 1 = Display 2 = Sensor 1 3 = Sensor 2	1		0
P21	Humidity Stat set point	0 to 100	1	% rH	30
P22	Humidity Stat diff	0 to 10	1	% rH	5
P23	Humidity Stat Input select	0 = None 1 = Display sensor 2 = Remote sensor 1 3 = Remote Sensor 2	1		1
P24	Humidity Stat type	0 = Cooling 1 = Heating	1		1
P25	Humidity Stat min set	0 to 100	1	% rH	20
P26	Humidity Stat max set	0 to 100	1	% rH	40
P60	Display	0 = Cycle 1 = Temperature Stat 2 = Humidity Stat	1		2
P61	Frost probe select	0 = Off 1 = Display probe 2 = Probe 1 3 = Probe 2 4 = Probe 3 5 = Probe 4	1		0
P62	Frost Detect	-59 to 128 (-74 to 262)	0.1	°C (°F)	0 (32)
P63	Frost Cut In	-42 to 60 (-43 to 140)	0.1	°C (°F)	10 (50)
P64	Display Offset	-10 to 10	0.1	°C (°F)	0 (32)
P10	Temp Stat High Alarm	-59 to 128 (-74 to 262)	0.1	°C (°F)	25 (77)
P11	Temp Stat Low Alarm	-59 to 128 (-74 to 262)	0.1	°C (°F)	-5 (23)
P12	Temp Stat Alarm Delay	00 to 99	1	mins	20
P30	Humidity Stat High Alarm	0 to 100	1	% rH	50



Please ensure all power is switched off before installing or maintaining this product.

Number	Parameter	Range °C (°F)	Step	Units	Def. °C (°F)
P31	Humidity Stat Low Alarm	0 to 100	1	% rH	10
P32	Hum. Stat Alarm Delay	00 to 99	1	mins	20
P70	Timer Mode	0 = local 1 = Remote 2 = Force Off 3 = Force On	1		0
P71	Sunday On Time 1	00:00 to 23:59	00:01	hr:min	08:00
P72	Sunday Off Time 1	00:00 to 23:59	00:01	hr:min	20:00
P73	Sunday On Time 2	00:00 to 23:59	00:01	hr:min	08:00
P74	Sunday Off Time 2	00:00 to 23:59	00:01	hr:min	20:00
P75	Monday On Time 1	00:00 to 23:59	00:01	hr:min	08:00
P76	Monday Off Time 1	00:00 to 23:59	00:01	hr:min	20:00
P77	Monday On Time 2	00:00 to 23:59	00:01	hr:min	08:00
P78	Monday Off Time 2	00:00 to 23:59	00:01	hr:min	20:00
P79	Tuesday On Time 1	00:00 to 23:59	00:01	hr:min	08:00
P80	Tuesday Off Time 1	00:00 to 23:59	00:01	hr:min	20:00
P81	Tuesday On Time 2	00:00 to 23:59	00:01	hr:min	08:00
P82	Tuesday Off Time 2	00:00 to 23:59	00:01	hr:min	20:00
P83	Wednesday On Time 1	00:00 to 23:59	00:01	hr:min	08:00
P84	Wednesday Off Time 1	00:00 to 23:59	00:01	hr:min	20:00
P85	Wednesday On Time 2	00:00 to 23:59	00:01	hr:min	08:00
P86	Wednesday Off Time 2	00:00 to 23:59	00:01	hr:min	20:00
P87	Thursday On Time 1	00:00 to 23:59	00:01	hr:min	08:00
P88	Thursday Off Time 1	00:00 to 23:59	00:01	hr:min	20:00
P89	Thursday On Time 2	00:00 to 23:59	00:01	hr:min	08:00
P90	Thursday Off Time 2	00:00 to 23:59	00:01	hr:min	20:00
P91	Friday On Time 1	00:00 to 23:59	00:01	hr:min	08:00
P92	Friday Off Time 1	00:00 to 23:59	00:01	hr:min	20:00
P93	Friday On Time 2	00:00 to 23:59	00:01	hr:min	08:00
P94	Friday Off Time 2	00:00 to 23:59	00:01	hr:min	20:00
P95	Saturday On Time 1	00:00 to 23:59	00:01	hr:min	08:00
P96	Saturday Off Time 1	00:00 to 23:59	00:01	hr:min	20:00
P97	Saturday On Time 2	00:00 to 23:59	00:01	hr:min	08:00
P98	Saturday Off Time 2	00:00 to 23:59	00:01	hr:min	20:00
dFLt	Restore defaults				



Please ensure all power is switched off before installing or maintaining this product.

Net - Network Configuration

The Intuitive Mercury Thermostat & Humidistat comes as standard with a built-in Ethernet TCP/IP network interface.

Network Options

In an IP system there are two options;

- IP-L
- IP-r

IP-L allows the user to assign a fixed IP address to the controller. This address would be used when connecting the controller to a customer's local area network (LAN). This allows the customer to view each controller using a compatible web browser such as Google chrome.

IP-r allows the user to assign each controller on the system a unique 3 digit network identifier. The controllers have an auto-initialise function, which will automatically log the device onto the site network, using the 3 digit identifier, and the Intuitive is allocated a dynamic IP address by the system DHCP server (such as the RDM Data Manager).

IP-L

To configure the device for IP-L mode the controller should be powered off, all three rotary switches set to zero and the controller powered back on.

1. nEt - From the function menu, select nEt
 - Press enter and the display will show "IP-L", press enter once more
 - You can now set the address using the table below

Display	Option
IP-1	IP Address byte 1
IP-2	IP Address byte 2
IP-3	IP Address byte 3
IP-4	IP Address byte 4
nL	Network Mask Length
gt-1	Gateway Address byte 1
gt-2	Gateway Address byte 2
gt-3	Gateway Address byte 3
gt-4	Gateway Address byte 4
ESC	Exit network menu. N.B. this option must be selected to save any changes made in this menu

To ease setup, a single network mask length value is used. If the address has been specified with a network mask value in dotted IP format e.g. 255.255.255.0 then the table below gives the conversion:

Mask	Length	Mask	Length	Mask	Length
		255.255.254.0	23	255.254.0.0	15
255.255.255.252	30	255.255.252.0	22	255.252.0.0	14
255.255.255.248	29	255.255.248.0	21	255.248.0.0	13
255.255.255.240	28	255.255.240.0	20	255.240.0.0	12
255.255.255.224	27	255.255.224.0	19	255.224.0.0	11
255.255.255.192	26	255.255.192.0	18	255.192.0.0	10
255.255.255.128	25	255.255.128.0	17	255.128.0.0	09
255.255.255.0	24	255.255.0.0	16	255.0.0.0	08

IP-r

To configure the device for IP-r, set the rotary switches to give each controller on the network a unique identifier. The three rotary switches must be set when the controller is powered off; the controller should then be powered on and connected to the network.

2. nEt - From the function menu, select nEt
 - Press enter and the display will show "IP-r", press enter once more
 - You can now view the address given (view only) by the DHCP server



Please ensure all power is switched off before installing or maintaining this product.

Bluetooth Network module

Connecting a Bluetooth Network Module to the controller will update the screens available under the 'Net' menu. They are detailed below;

Display	Option
485t	1: 485 Genus Network (See RS485 module/ Intuitive Internal RS485 Network card) 2: Bluetooth
485A	Bluetooth device name. As it will appear on DMTouch's device list (RC00-0 – RC99-9)
nI d	Select Bluetooth Network ID (0 – 4)
gAdd	Shows underlying network address assigned to controller
rLog	Re-log the controller back onto the network
CLrA	Clear the address/ name from the controller
ESC	Exit network menu. Note: this option must be selected to save any changes made in this menu.

- Ensure the 485t is set to '2' (Bluetooth)
- Provide a unique device alias under the 485A menu (e.g. 01-5)
- Select the Network ID. Please see the Bluetooth wireless mesh setup guide for more details.
- Press the 'ESC' to save

The green network LED will flash to show it is attempting to log on and go solid when connected.

IO - Viewing Inputs & Outputs

Apart from setting up the controller, you can also view the status of the inputs, outputs and controller states. From the function menu, select "I/O" and press enter. You can now scroll through the IO table as set out below;

Input / Output Table – Type 1 - Triple Thermostat

Number	IO	Range oC (oF)	Step	Units
I-01	Stat A Ctrl Temp	-59.0 to 128.0°C (-74.2 to 262.4°F)	0.1	Deg
I-02	Stat B Ctrl Temp	-59.0 to 128.0°C (-74.2 to 262.4°F)	0.1	Deg
I-03	Stat C Ctrl Temp	-59.0 to 128.0°C (-74.2 to 262.4°F)	0.1	Deg
I-10	Display Temp	-59.0 to 128.0°C (-74.2 to 262.4°F)	0.1	Deg
I-11	Display Humidity	0 to 100%	1	rH
I-21	Stat A Temp	-59.0 to 128.0°C (-74.2 to 262.4°F)	0.1	Deg
I-22	Stat B Temp	-59.0 to 128.0°C (-74.2 to 262.4°F)	0.1	Deg
I-23	Stat C Temp	-59.0 to 128.0°C (-74.2 to 262.4°F)	0.1	Deg
I-24	Frost Probe Temp	-59.0 to 128.0°C (-74.2 to 262.4°F)	0.1	Deg
O-01	Relay 1	0 (Off), 1 (On)		
O-02	Relay 2	0 (Off), 1 (On)		
O-03	Relay 3	0 (Off), 1 (On)		
O-04	Relay 4	0 (Off), 1 (On)		
O-05	Relay 5	0 (Off), 1 (On)		
O-11	Timer State	0 (Off), 1 (On)		
O-22	Overrun	0 to 6	1	Hrs
O-33	Stat A Offset	0 to 60 (32 to 140)	0.1	Deg
O-34	Stat B Offset	0 to 60 (32 to 140)	0.1	Deg
O-34	Stat C Offset	0 to 60 (32 to 140)	0.1	Deg
S-01	Control State 1	0 (Off), 1 (Stabilise), 2 (Normal), 3 (Alarm)	1	
S-02	Control State 2	0 (Off), 1 (Stabilise), 2 (Normal), 3 (Alarm)	1	
S-03	Control State 3	0 (Off), 1 (Stabilise), 2 (Normal), 3 (Alarm)	1	



Please ensure all power is switched off before installing or maintaining this product.

Input / Output Table - Type 2 - Temperature and Humidity Thermostat with timer

Number	IO	Range oC (oF)	Step	Units
I-01	Stat Ctrl Temp	-59.0 to 128.0°C (-74.2 to 262.4°F)	0.1	Deg
I-02	Control Humidity	0 to 100%	1	rH
I-10	Display Temp	-59.0 to 128.0°C (-74.2 to 262.4°F)	0.1	Deg
I-11	Display Humidity	0 to 100%	1	rH
I-21	Stat Temp	-59.0 to 128.0°C (-74.2 to 262.4°F)	0.1	Deg
I-24	Frost Probe	-59.0 to 128.0°C (-74.2 to 262.4°F)	0.1	Deg
O-01	Relay 1	0 (Off), 1 (On)		
O-02	Relay 2	0 (Off), 1 (On)		
O-03	Relay 3	0 (Off), 1 (On)		
O-04	Relay 4	0 (Off), 1 (On)		
O-05	Relay 5	0 (Off), 1 (On)		
O-11	Timer State	0 (Off), 1 (On)		
O-22	Overrun	0 to 6	1	Hrs
O-33	Stat Offset	0 to 60 (32 to 140)	0.1	Deg
S-01	Control State 1	0 (Off), 1 (Stabilise), 2 (Normal), 3 (Alarm)	1	
S-02	Control State 2	0 (Off), 1 (Stabilise), 2 (Normal), 3 (Alarm)	1	

OFSt -Probe Offset

This feature allows each probe value to be modified by an "offset". Offset values are from -10°C (-18°F) to +10°C (+18°F) and on a channel basis. E.g. C-01 = Probe 1, C-02 = Probe 2 etc.

Display Messages

The following alarms and messages can appear on the controller display.

Display Message	System status
rhFt	Humidity sensor fault
Ft	Temperature probe fault

Network Alarms

The table below shows the text and associated type number that is sent to the system "front end". The type number is normally used to provide different alarm actions.

Alarm text	Type # (index)
Display Probe Fault	6
Display Sensor Fault	6
Stat A Probe Fault	6
Stat A Over Temperature	4
Stat A Under Temperature	5
Stat B Probe Fault	6
Stat B Over Temperature	4
Stat B Under Temperature	5
Stat C Probe Fault	6
Stat C Over Temperature	4
Stat C Under Temperature	5
Humidity Sensor Fault	6
High Humidity Alarm	8
Low Humidity Alarm	9



Please ensure all power is switched off before installing or maintaining this product.

Faults

If a fault is detected, the controller will indicate the fault on the display and the red alarm LED will come on. The alarm relay will also change states; Wired to the N/O and common contacts; if there are no alarms present this will 'make' a circuit. If there is an alarm present, the circuit will be broken. Note – temperature alarms will not be shown on the display.

GP Timer Set-up

It is possible to set the Control Stat timer for 'remote' operation (P70 = 1). A GP Timer must be set up from the Data Manager. For GP Timer set up, please refer to the Data Manager User guide found on the RDM website. For the GP timer channel to send on/off signals to the Humidistat, the following settings should be followed;

- Output Type – This should be set to "General"
- Output Mask – This should match the exact controller name as seen on the Data Manager's Device list
- Output Channel – Set this to "5". This will allow the GP Timer to control the state of the controller timer.

Operation:

Type 1: Triple Thermostat

This controller has 3 temperature thermostat functions, A, B and C. They can be used as independent thermostats by selecting a different input for each function. Alternatively, they can be used as a 2 or 3 stage thermostat by selecting the same input. Or they can be switched off.

All three thermostat functions have their own cut in and associated diff which can be set for cooling mode (diff is below the set-point) or heating mode (diff is above the set-point).

Thermostat A switches relay 1, thermostat B switches relay 2, and thermostat C switches relay 3. If the comfort index is enabled, the control temp is offset by a value according to the humidity value ([see appendix 1: Humidity/ temperature chart](#)). The Display temperature is also similarly adjusted.

To change a set point value, press the up and down button together for a short time (2 seconds); the display will show thermostat A's set-point (such as "15.0"), press enter to accept the adjustment and display thermostat B's set-point (such as "20:0"), repeating, moves through the set-points A, B and C. Note that the alarm levels will also change by the same value as the set point is changed.

High and Low alarm limits can be set for each thermostat. When the unit is in any alarm state, the Alarm relay (No 5) will be activated.

The controller has a built in 2-on/ 2-off, seven day timer. The controller will continue to display outside of the set times, but the control relays will not function. When 'in hours' the Timer Relay (No 4) will be active, 'out of hours' it will be inactive, also the amber LED indicates when outside of the set times (illuminated for out of hours).

Type 2: Temp and Humidity Thermostat with timer

This controller has 2 control functions; a temperature thermostat that switches relay 1, and a humidistat that switches relay 2. Both stat functions have their own diff, and can be set for cooling mode (diff is below the set-point) or heating mode (diff is above the set-point).

If the Comfort Index is enabled, the control temp is offset by a value according to the humidity value ([see appendix 1: Humidity/ temperature chart](#)). The Display temperature is also similarly adjusted.

High and Low alarm limits can be set for each thermostat. When the unit is in any alarm state, the Alarm relay (No 5) will be activated.

Set points can be changed in the same manner as described in the above paragraph.

The controller has a built in 2-on/ 2-off, seven day timer. The controller will continue to display outside of the set times, but the control relays will not function. When 'in hours' the Timer Relay (No 4) will be active, 'out of



Please ensure all power is switched off before installing or maintaining this product.

hours' it will be inactive, also the amber LED indicates when outside of the set times (illuminated for out of hours).

Frost Detect

Frost detect is included in both type 1 and type 2 controllers. Frost Detect works when the timer is off, and the frost probe reaches the frost detect value (P62). In the state of 'frost detected' the thermostats (all three if configured) will operate to the frost cut-in (P63) and use the configured dif values (P02, P22, P41) until the frost detect value (+2 deg dif) is exceeded.

NB - If the same probe is used for both the thermostat and frost detect, 'hunting' may occur around the frost detect point. It is better to use separate probes.

Set point Adjustment from Display

On the display panel, holding both the 'up' and 'down' buttons will enter into a menu allowing the adjustment of the current set points. Within the parameters, the limitations allowed on these adjustments can be modified (P-05, 06, 25, 26, 45, 46). As default, the min and max values allowed to increment the set points are -5.0 (-10 degF) and +5.0 (+10 degF) respectively.

NB - the offsets changed on the display panel will be shown as outputs on the device both through the controller's and Data Manager's web page.

Cooling Thermostat graph

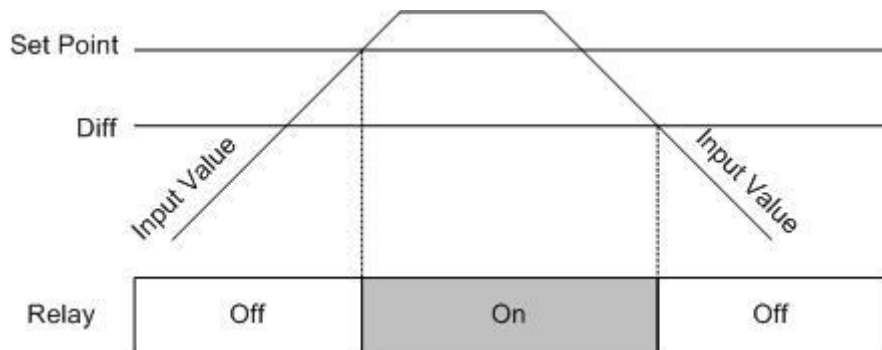

Heating Thermostat graph

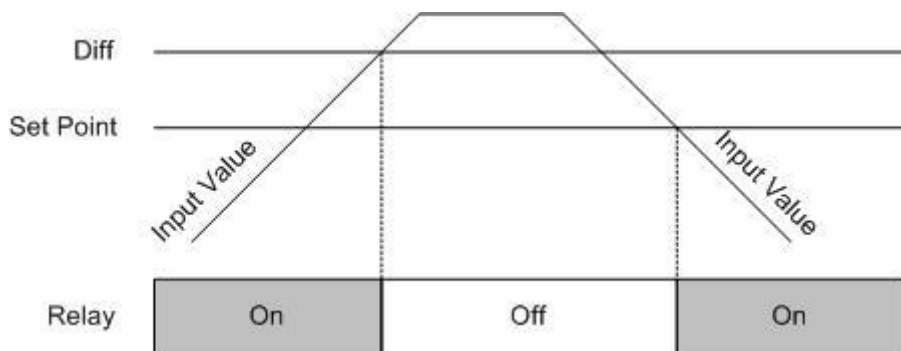

Please ensure all power is switched off before installing or maintaining this product.

Specification

Power Requirements	
Supply Voltage Range	100 – 240 Vac \pm 10%
Supply Frequency	50 – 60 Hz
Typical Supply Current	250mA
Maximum Supply Current	2 Amps
General	
Operating Temperature Range	-10°C to +60°C
Storage Temperature Range	-20°C to +65°C
Environmental	Indoor use at altitudes up to 2000m, pollution degree 1, installation category II. Voltage fluctuations not to exceed \pm 10% of nominal voltage.
Size	157mm (W) x 67mm (H) x 120 (D)
Weight	500 grams
Safety	EN61010
EMC	EN61326-1 : 2013
Class 2 Insulation	No protective Earth is required and none should be fitted
Supply Fuse	The controller has a built in fuse. Fuse type 2A 240Vac Anti-surge (T) HRC conforming to IEC60127, 32 x 6.3mm
MCB	2A, 240 VAC Type C conforming to BS EN 60898 (Note: controller has integral 2A fuse)
Relay Output Fuse	10A 240Vac Anti-surge (T) HRC conforming to IEC60127, 32 x 6.3mm
Comms	IP Network
Relay Specification	
Relays Exclusive Common	
Max current	10A Resistive ($\text{Cos}\phi = 1$) 2A Inductive ($\text{Cos}\phi = 0.4$)
Max voltage	250Vac. 30V dc
Relay Fuse	10A 240Vac Anti-surge (T) HRC conforming to IEC60127, 32 x 6.3mm
Relay Life Expectancy	For trim heater control applications (inductive load) a maximum switchable current of 2A is allowed during operation. This will provide a relay life expectancy greater than 5 years. If the current switched is more than 2A the relay life expectancy will be below 5 years and the controller warranty will become invalid. Warning if the full current of 10A is switched the relay life expectancy is less than 6 months.
Safety	Conforms to EN60730-1 based on UL 60950-1; UL 62368-1 as referenced to IEC60730-1
Inputs	
Probe Inputs	3.01K Ohms - 0V Return
1-3 Vdc Input	This is for use with a 3rd party Humidity sensor (Farnell Part 2070548 or equivalent). Connect sensor which provides a 1 to 3 Vdc signal, a 5V supply is provided to feed the sensor. 1V equates to 0% rH and 3V equates to 100% rH.
Display Sensor Accuracy (PR0445)	
Temperature Range	+5°C to +50°C Accuracy +/- 0.4 Degrees Celsius
Humidity Range	20% to 80% Accuracy +/- 3% rH



Please ensure all power is switched off before installing or maintaining this product.

Installation

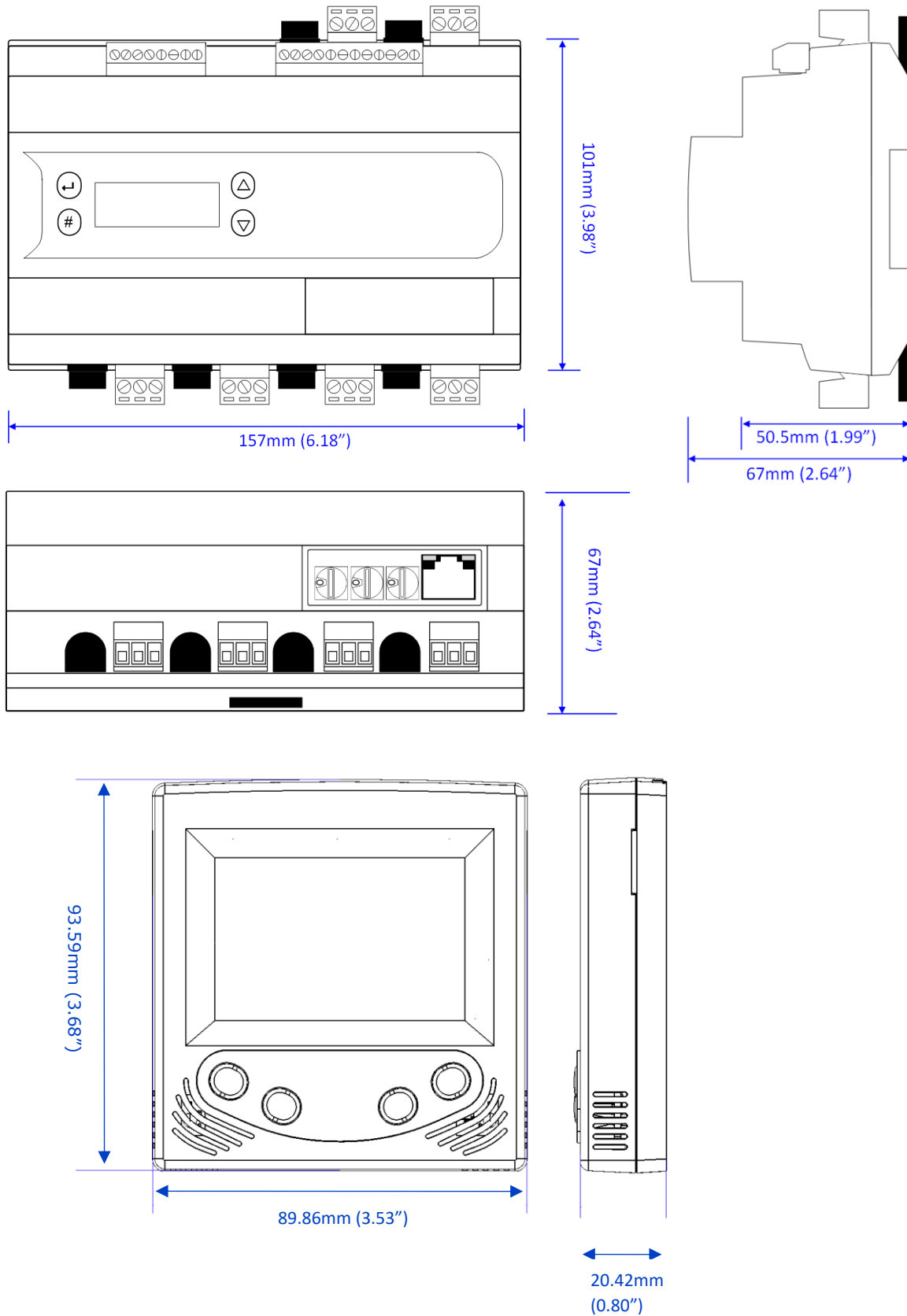

The display is supplied with a mounting bracket. The bracket is removed from the display by removing the two screws on the underside of the display and sliding the bracket downwards and then away from the display.



Please ensure all power is switched off before installing or maintaining this product.

Mounting Instructions - Intuitive

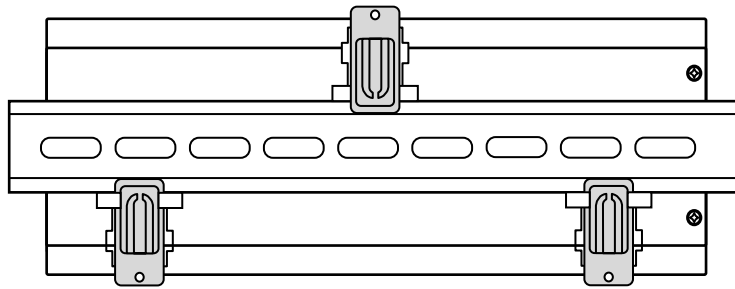

Three clips fix the Intuitive Mercury securely to DIN rail. Pull each clip until it “clicks” to remove the controller. Each clip has a mounting hole to provide an alternative fixing mechanism to DIN mounting.

The Humidistat Display is designed to fix on to a single socket pattress, either wall or flush mount.

Mounting Instructions - Display

The screen display is supplied with a mounting bracket. The bracket is removed from the display by removing the two screws on the underside of the display and sliding the bracket downwards and then away from the display. The mounting plate can then be fitted to the desired surface using the mounting holes shown below. Two of the mounting holes match the position of the threaded inserts on a standard UK pattress box, providing another mounting option.

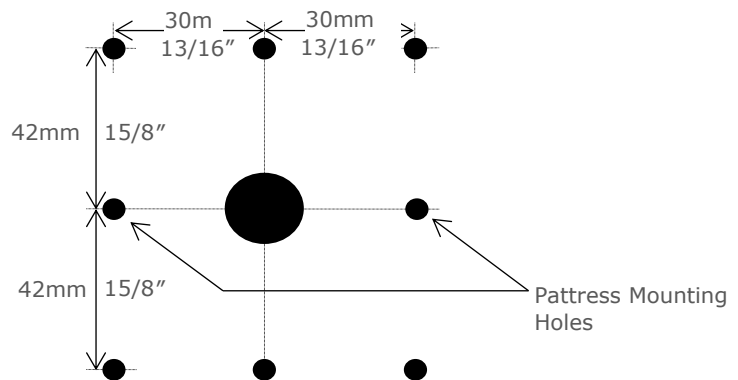

Fitting the Display to the Mounting Bracket

Care should be taken with regards to plug orientation when re-connecting.

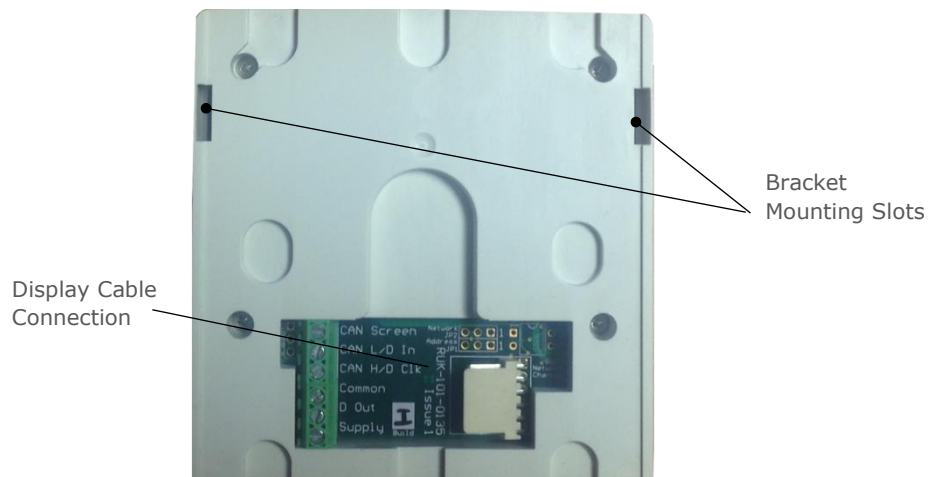

The display should be positioned on the bracket so that the two mounting lugs on the bracket locate in the two slots in the back of the display. The display is then moved down so that the two screw holes at the bottom of the bracket meet up with the two threaded inserts at the bottom of the display. The two mounted screws are then fitted to secure the display onto the bracket.



Please ensure all power is switched off before installing or maintaining this product.

Cleaning

Do not wet the controller when cleaning. Clean the front by wiping with slightly dampened lint free cloth.

Disclaimer

The specifications of the product detailed in this document may change without notice. RDM Ltd shall not be liable for errors or omissions, for incidental or consequential damages, directly or indirectly, in connection with the furnishing, performance or misuse of this product or document.

Appendix 1 Comfort Index

Apparent Temperature for Values of Room Temperature and Relative Humidity (Shown in Degree F)

	0%	5%	10%	15%	20%	25%	30%	35%	40%	45%	50%	55%	60%	65%	70%	75%	80%
115	117.1	118.0	119.0	119.9	120.8	121.6	122.5	123.5	124.4								
110	111.1	112.0	113.0	113.9	114.8	115.6	116.5	117.5	118.4	119.3	120.1						
105	105.1	106.0	107.0	107.9	108.8	109.6	110.5	111.5	112.4	113.3	114.1	115.0	116.0				
100	99.2	100.1	101.0	101.9	102.8	103.7	104.6	105.5	106.4	107.3	108.2	109.1	110.0	110.9	111.8		
95	93.1	94.0	95.0	95.9	96.8	97.6	98.5	99.5	100.4	101.3	102.1	103.0	104.0	104.9	105.8	106.6	107.5
90	87.1	88.0	89.0	89.8	90.7	91.6	92.5	93.4	94.3	95.2	96.1	97.0	97.9	98.8	99.7	100.6	101.5
85	81.1	82.0	83.0	83.9	84.8	85.6	86.5	87.5	88.4	89.3	90.1	91.0	92.0	92.9	93.8	94.6	95.5
80	75.1	76.0	77.0	77.9	78.8	79.6	80.5	81.5	82.4	83.3	84.1	85.0	86.0	86.9	87.8	88.6	89.5
75	69.2	70.1	71.0	71.9	72.8	73.7	74.6	75.5	76.4	77.3	78.2	79.1	80.0	80.9	81.8	82.7	83.5
70	63.1	64.0	65.0	65.8	66.7	67.6	68.5	69.5	70.3	71.2	72.1	73.0	74.0	74.8	75.7	76.6	77.5

Apparent Temperature for Values of Room Temperature and Relative Humidity (Shown in Degree C)

	0%	5%	10%	15%	20%	25%	30%	35%	40%	45%	50%	55%	60%	65%	70%	75%	80%
46.1	47.3	47.8	48.3	48.8	49.3	49.8	50.3	50.8	51.3								
43.3	43.9	44.4	44.9	45.1	45.9	46.4	46.9	47.4	47.9	48.4	48.9						
40.6	40.7	41.2	41.7	42.2	42.7	43.2	43.7	44.2	44.7	45.2	45.7	46.2	46.7				
37.8	37.3	37.8	38.3	38.8	39.3	39.8	40.3	40.8	41.3	41.8	42.3	42.8	43.3	43.8	44.3		
35.0	34.0	34.5	35.0	35.5	36.0	36.5	37.0	37.5	38.0	38.5	39.0	39.5	40.0	40.5	41.0	41.5	42.0
32.2	30.6	31.1	31.6	32.1	32.6	33.1	33.6	34.1	34.6	35.1	35.6	36.1	36.6	37.1	37.6	38.1	38.6
29.4	27.2	27.7	28.2	28.7	29.2	29.7	30.2	30.7	31.2	31.7	32.2	32.7	33.2	33.7	34.2	34.7	35.2
26.7	24.0	24.5	25.0	25.5	26.0	26.5	27.0	27.5	28.0	28.5	29.0	29.5	30.0	30.5	31.0	31.5	32.0
23.9	20.6	21.1	21.6	22.1	22.6	23.1	23.6	24.1	24.6	25.1	25.6	26.1	26.6	27.1	27.6	28.1	28.6
21.1	17.3	17.8	18.3	18.8	19.3	19.8	20.3	20.8	21.3	21.8	22.3	22.8	23.3	23.8	24.3	24.8	25.3



Please ensure all power is switched off before installing or maintaining this product.

Revision History

Revision	Date	Changes
2.0	11/07/13	First Release. Note document revision matches controller application software revision.
2.0a	05/01/15	Operating temperature range increased
2.0b	30/03/15	Update of USA address
2.0c	01/06/15	EMC standard updated.
2.1	08/03/18	New Display support added.
2.1a	13/03/18	New Documentation format.
3.1	15/12/20	New Intuitive Mercury Hardware, Bluetooth support added.



Please ensure all power is switched off before installing or maintaining this product.

Group Offices

RDM Group Head Office
80 Johnstone Avenue
Hillington Industrial
Estate
Glasgow
G52 4NZ
United Kingdom
+44 (0)141 810 2828
support@resourcedm.com

RDM USA
9441 Science Center Drive
New Hope
Minneapolis
MN 55428
United States
+1 612 354 3923
usasupport@resourcedm.com

RDM Asia
Sky Park at One City
Jalan USJ 25/1
47650 Subang Jaya
Selangor
Malaysia
+603 5022 3188
asiatech@resourcedm.com



Visit www.resourcedm.com/support for more information on RDM solutions, additional product documentation and software downloads.

While every effort is made to ensure the information given within this document is accurate, Resource Data Management Ltd shall not be liable for errors or omissions, for incidental or consequential damages, directly or indirectly, in connection with the furnishing, performance or misuse of this product or document. All specifications are subject to change without notice.

See www.resourcedm.com for terms and conditions of sales.

Copyright © Resource Data Management