

**Intuitive**

**PR0650-TDB-ENG  
PR0650D-TDB-ENG**

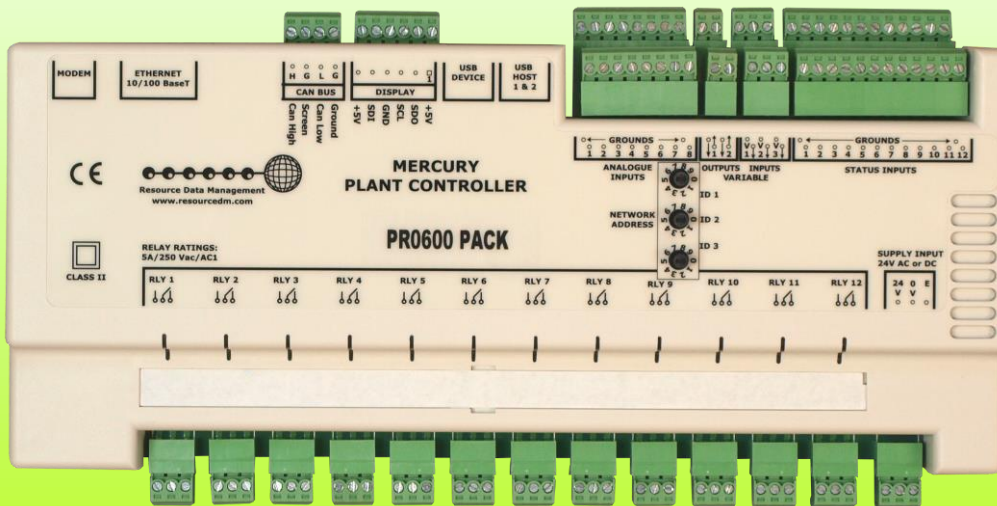

**Plant**

**PR0600-TDB-ENG**

# Intuitive and Plant EMS Controller Installation & User Guide

Resource Data Management Ltd

80 Johnstone Avenue, Hillington Industrial Estate,  
Glasgow, Scotland G52 4NZ UK

☎ +44(0)141 810 2828

✉ [support@resourcedm.com](mailto:support@resourcedm.com)

✉ [sales@resourcedm.com](mailto:sales@resourcedm.com)

Switchboard

Technical Support

Sales Enquiries



**Table of Contents:**

**THE INTUITIVE AND MERCURY RANGE ..... 3**

**Description ..... 3**

**Configuration ..... 3**

**Integral Display (PR0650D-TDB-ENG) ..... 3**

    Section 1 Display ..... 3

    Section 2 Display ..... 3

    Front Panel Remote Display Buttons ..... 3

**Mercury Plant Controller I/O Connections ..... 4**

**Mercury Plant Controller I/O Connections ..... 4**

    Mercury Plant Controller Variable Analogue Input / Output Connections ..... 4

**Intuitive Plant Controller I/O Connections ..... 5**

    Intuitive Plant Controller, Input / Output Connections ..... 6

**Networks ..... 6**

**I/O Screen Shot: - ..... 7**

**Functional description of Inputs ..... 8**

**Parameters: Screen Shot ..... 9**

    Parameters Description ..... 9

    Setting Up ..... 11

**Specification ..... 12**

    Power requirements: ..... 12

    General ..... 12

    Inputs ..... 12

    Relay Ratings, Mercury Plant Controller ..... 12

    Relay Ratings, Intuitive Plant Controller ..... 12

    Fuse Ratings, Intuitive Plant Controller ..... 12

**Installation: ..... 13**

    Mounting on to a DIN rail, Mercury Plant Controller ..... 13

    Mounting on to a DIN rail, Intuitive Plant Controller ..... 14

    Clearances: ..... 14

    Cleaning: ..... 14

**APPENDIX 1 SETTING LOCAL GP TIMERS ..... 15**

    GP Channels page ..... 15

    GP Channel as a Master ..... 16

    GP Channel as a Slave ..... 16

**APPENDIX 2 REMOTE DATA MANAGER GP TIMERS ..... 17**

**Disclaimer ..... 17**

**APPENDIX 3 – SUPPLY & STATUS INPUT WIRING ..... 18**

**REVISION HISTORY ..... 19**



Ensure that all power is switched off before installing or maintaining this product

## The Intuitive and Mercury Range

### From Resource Data Management

This documentation refers to the controllers Mercury Plant Controller and Intuitive Plant Controller

#### Description

This controller is intended for Co-op installations for energy saving. It has twelve relay channels which switch various functions around the store. It is intended to be used in conjunction with a Data Manager, but can operate as a “stand-alone” controller.

Intuitive / Plant Controller Descriptions	Part Number
Intuitive Controller with Pack application (No Internal Display)	PR0650-TDB-ENG
Intuitive Controller with Pack application (Internal Display)	PR0650D-TDB-ENG
Plant Controller with Pack Application	PR0600-TDB_ENG

#### Configuration

The controller has a pre-defined TDB program embedded, no further programming other than parameter settings are necessary, other than setting up the internal GP Timers (for stand-alone and backup use) and the Data Manager GP timers when in a networked store.

#### Integral Display (PR0650D-TDB-ENG)

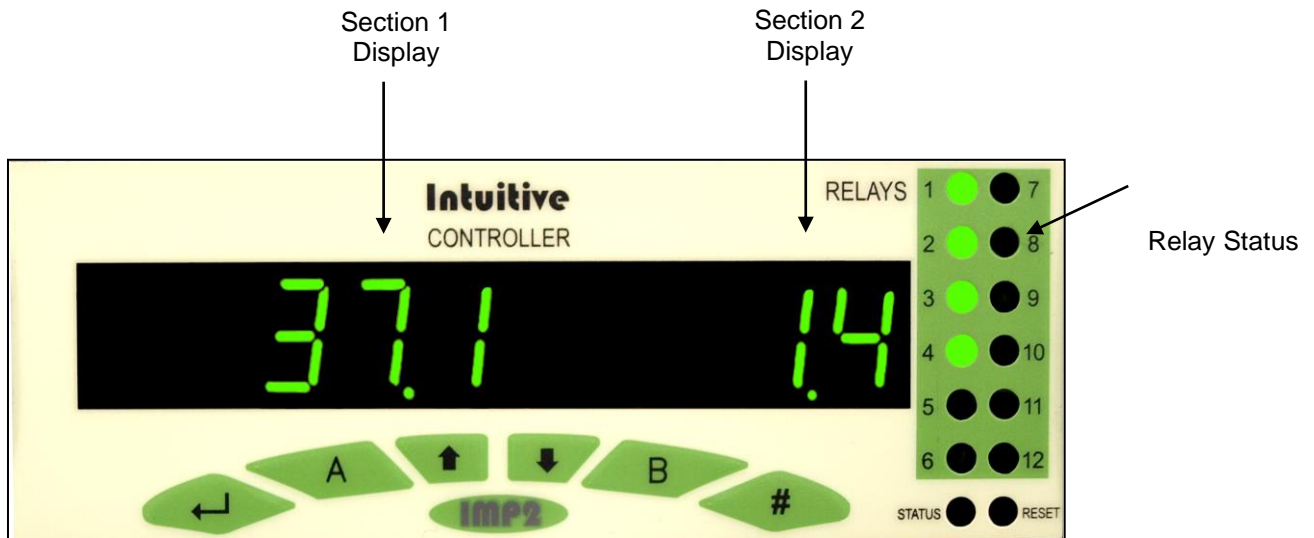

All buttons are inoperable for this controller

#### Section 1 Display

Section 1 displays the “Store Average Temperature”

#### Section 2 Display

Section 2 displays the “Outside Ambient Temperature”

#### Front Panel Remote Display Buttons

All buttons are inoperable.



Ensure that all power is switched off before installing or maintaining this product

## Mercury Plant Controller I/O Connections

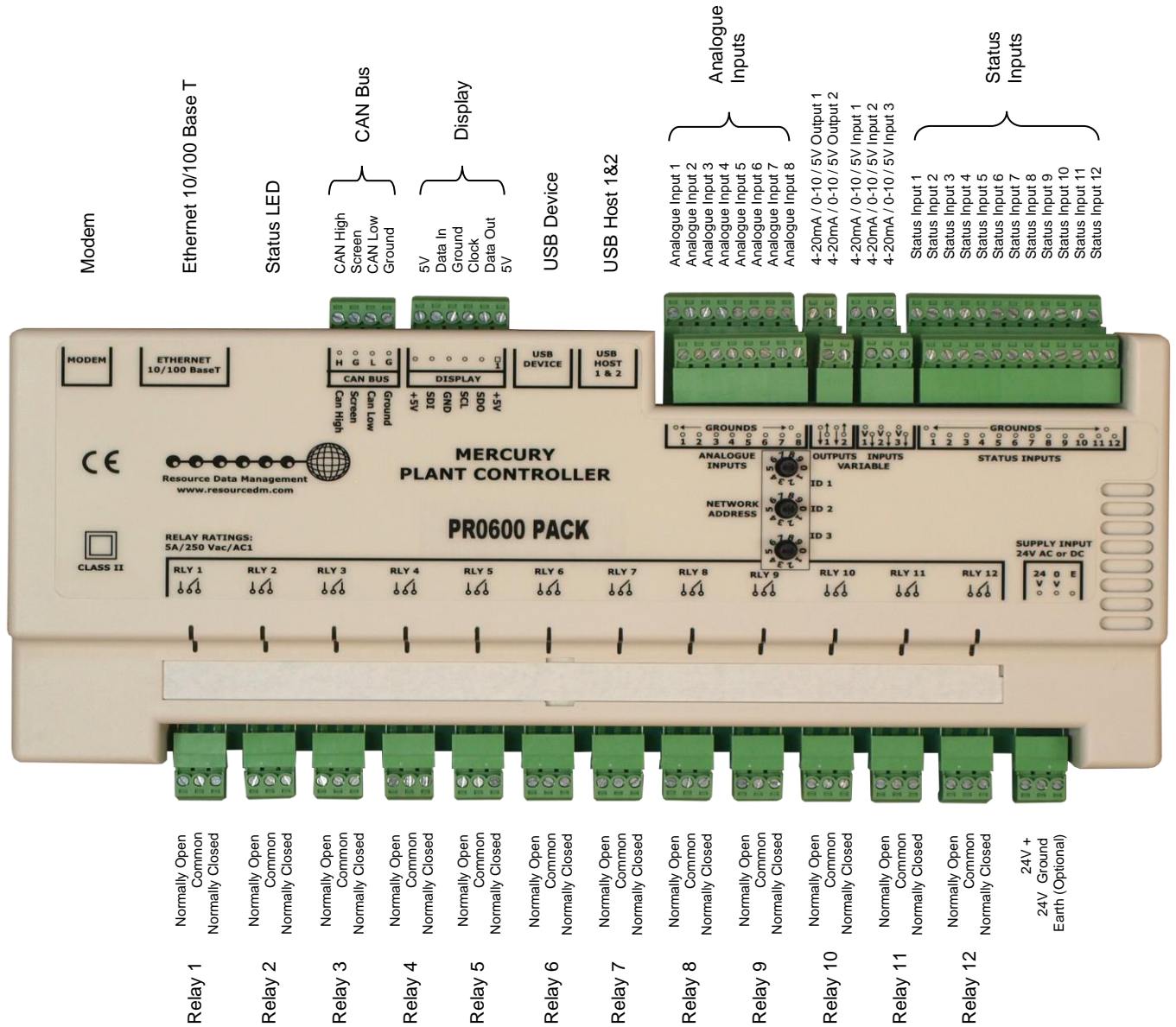

## Mercury Plant Controller Variable Analogue Input / Output Connections

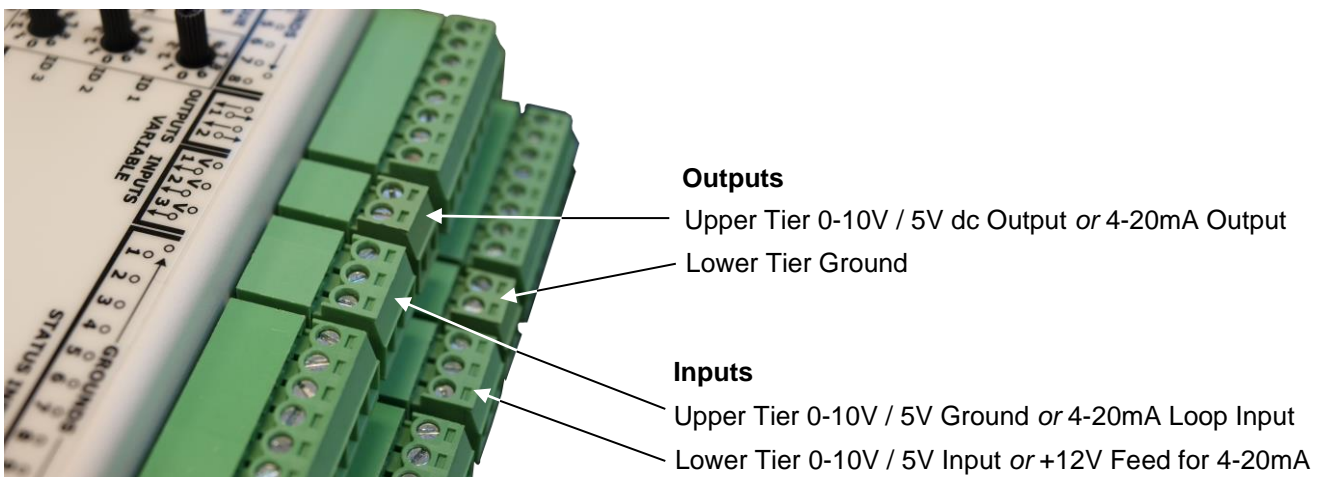

Ensure that all power is switched off before installing or maintaining this product

## Intuitive Plant Controller I/O Connections

Bottom Row Connections

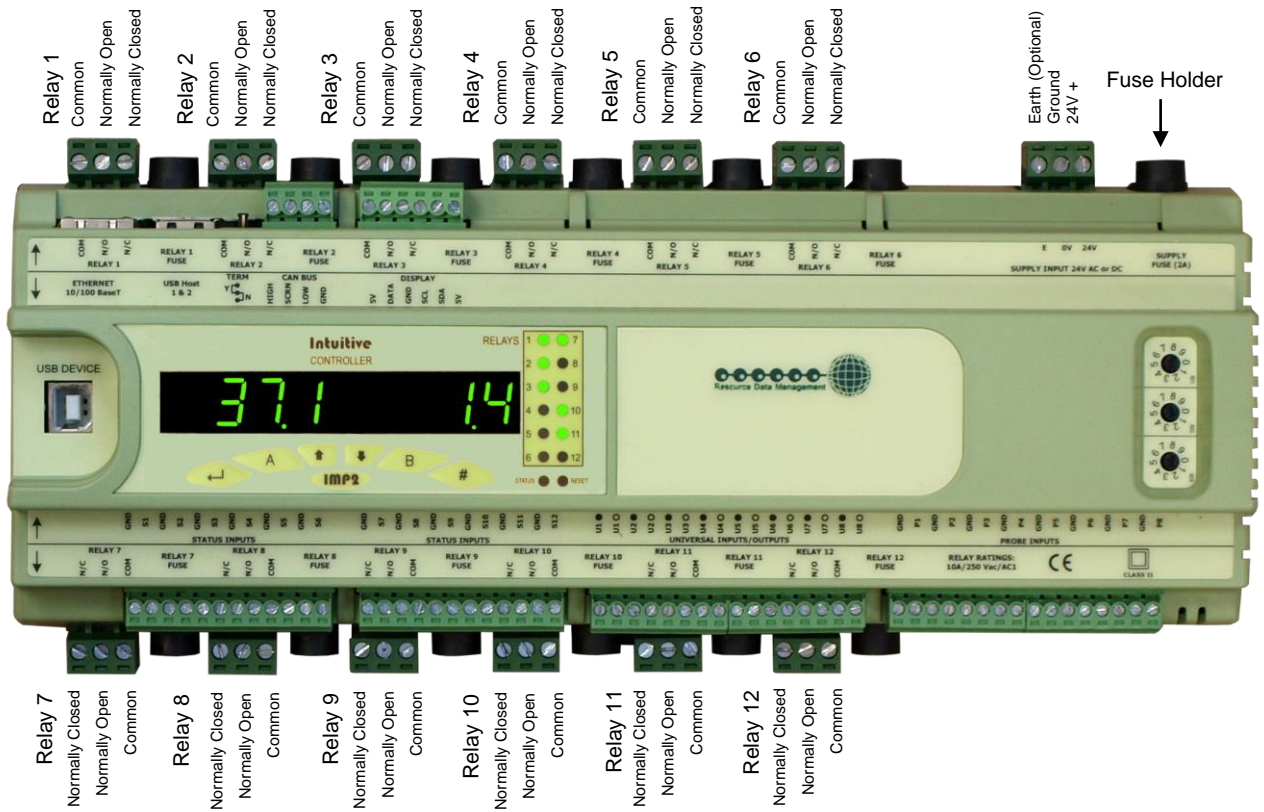

Top Row Connections

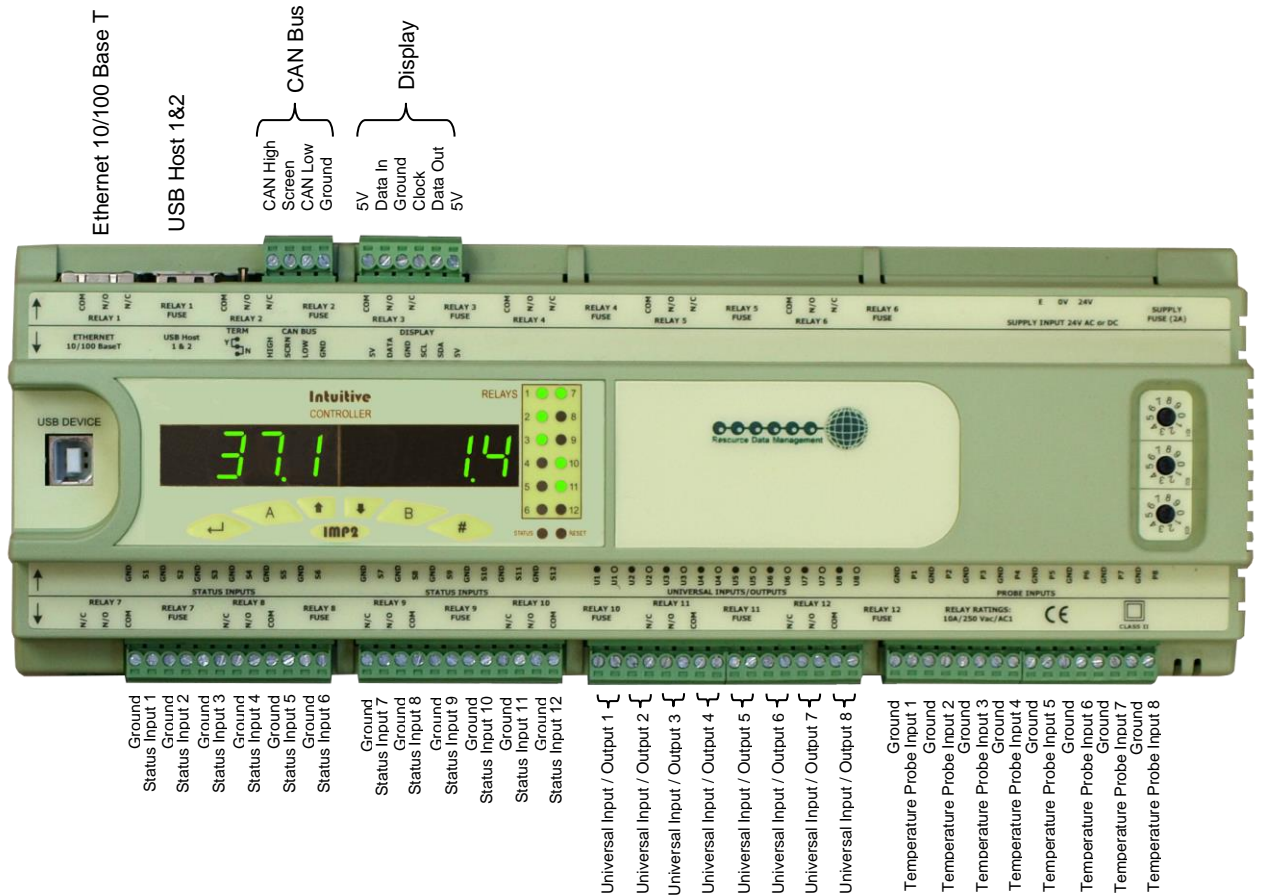

Ensure that all power is switched off before installing or maintaining this product

## Intuitive Plant Controller, Input / Output Connections

All Types	Description	Comments
Status Input 1	Alarm System	0 Volt return (N/C)
Status Input 2	Intruder Loop	0 Volt return (N/C)
Status Input 3	Override (Panel point)	0 Volt return (N/O)
Status Input 4	Override (Entry point)	0 Volt return (N/O)
Status Input 5	Car Park Override	0 Volt return (N/O)
Status Input 6	Data Manager Alarm	0 Volt return (N/O)
Status Input 7	Not Used	
Status Input 8	Not Used	
Status Input 9	Not Used	
Status Input 10	Not Used	
Status Input 11	Not Used	
Status Input 12	Not Used	
Analogue/Temperature Input 1	Internal Temperature probe	PT1000 Type
Analogue/Temperature 2	Internal Temperature probe	PT1000 Type
Analogue/Temperature 3	External Temperature probe	PT1000 Type
Analogue/Temperature 4	Internal Temperature probe for AC2	PT1000 Type
Analogue/Temperature 5	Not Used	
Analogue/Temperature 6	Not Used	
Analogue/Temperature 7	Not Used	
Analogue/Temperature 8	Not Used	(short circuit forces test mode)
4-20mA Input/Universal 1	Light Sensor 1	Outside for car park lights
4-20mA Input/Universal 2	Light Sensor 2	Internal light sensor for Chan12
4-20mA Input/Universal 3	Not Used	
4-20mA Output 1/Universal 4	Not Used	
4-20mA Output 2/Universal 5	Not Used	
Relay 1	Stage 1 Lights	Volt Free <b>See note 1</b>
Relay 2	Stage 2 Lights	Volt Free
Relay 3	Feature Lights	Volt Free
Relay 4	Signage Lights	Volt Free
Relay 5	Car park/Perimeter Lights	Volt Free
Relay 6	AC 1	Volt Free
Relay 7	AC 2	Volt Free
Relay 8	Heating System	Volt Free
Relay 9	Over-door Heater	Volt Free
Relay 10	BWS Lights	Volt Free
Relay 11	Soft Drinks Lights	Volt Free
Relay 12	Lighting channel with Photocell control OR Alarm	Volt Free

**Note 1:** All circuits use the N/C contact to switch a contactor coil, the contactor will use a N/C circuit to switch the function. Thus when the controller relay is energised the circuit function is off.

### Networks

The controller has a built-in Ethernet network interface that allows for connection to an RDM Data Manager system without the need for an extra communications module. Set the 3 rotary switches to the desired unique network ID.

If a PC connection to the controller is required (for viewing in a stand-alone system or before the controller is connected to a network; carry USB to PC connection procedures. (User guide for this operation can be found on the RDM website)



Ensure that all power is switched off before installing or maintaining this product

**I/O Screen Shot: -**

The following illustration shows the I/O (Control Summary) page of the controller when directly connected to a PC: -

Input	Value	Unit	Output	Value	Unit
Burglar Alarm System	Off		Stage 1 Lights	On	
Intruder loop: On=OK	On		Stage 2 Lights	On	
Panel Override Switch	Off		Feature Lights	On	
Entry Point Override Switch	Off		Sign Lights	Off	
Store Average Temperature	-1.5	Deg. C	Car Park Lights	Off	
External Ambient Temperature	???	Deg. C	Air Con Stage 1	Off	
AC 2 Temperature	-1.3	Deg. C	Air Con Stage 2	Off	
Internal Photocell	???	Lux	Heating	On	
Car Park Override	Off		Overdoor Heaters	On	
Car Park Photocell	???	Lux	BWS Areas	Off	
			Soft Drinks	Off	
			Chan 12	Off	
			AC1 Day stat	Off	
			AC1 Night stat	Off	
			Store Probe Fail	Off	
			Full Override	Off	
			Security Override	Off	
			DM Timer for Stage 2 Lights	Off	
			DM Timer for Signage Lighting	Off	
			DM Timer for Car park Lights	Off	
			DM Timer for Heating Control	Off	
			DM Timer for BWS Area	Off	
			DM Timer for AC2	Off	
			DM Timer for Feature Lighting	Off	
			DM Timer for Softdrinks Area	Off	
			DM Timer for Relay 12	Off	
			DM Timer for Frost Stat	Off	
			DM Timer for Season Change	Off	
			Test Mode	Off	
			AHU Day Stat	On	
			AHU Night Stat	Off	

State	Value
Version	PR0600 V6.0
Panel Status	Trading
Season	Winter
Heating Channel	AHU
Shop Floor Probes Used	Probe 1
Stage 2 Timer	Local On
Signage Timer	Local Off
Car Park Timer	Local Off
Heating Timer	Local Off
BWS Timer	Local Off
AC2 Timer	Local Off
Feature Timer	Local On
Softdrinks Timer	Local Off
R12 Timer	Local Off
Frost Stat Timer	Local Off



Ensure that all power is switched off before installing or maintaining this product

## Functional description of Inputs

Input	Name	Electrical	Description of Operation
Status 1	Alarm System	0Volt return	This is an input from the alarm security panel, normally when the security panel is armed (out of hours) the 0Volt return is present (On). When the alarm panel is deactivated by the security code, this input becomes open (Off) When the input is off, the stage 1 lights (relay1) are turned on and this input is used to enable the other functions in the controller. When the alarm panel is activated (by the security code) the input is returned (0Volt loop = on) and all functions are disabled apart from the stage 1 lights where there is a preset delay before they go off. This input basically is the "Store Occupied" signal.
Status 2	Intruder loop	0Volt return	This is an input from the alarm security panel, it is normally closed except when there is an Intruder Alert from the panel. When this input goes open, the stage 1 lights come on immediately, stage 2 lights come on after a short delay, car park lights come on after a short delay. When the loop is returned, (Loop = on) stage 1 lights, stage 2 lights and car park lights go off. The car park lights operation also depends on the Lux sensor, if the lux sensor is showing daylight, the car park lights will not come on, if the lux sensor is in the night zone, then the operation is as described above.
Status 3	Panel Override	0Volt return	This input is normally open, where it has no effect. When the input is closed (0Volt loop = on) all the controller functions are turned on. The car park lights will follow the lux sensor output. The Ac1 and Ac2 outputs will be permanently enabled whilst this input is active. (bypasses the temperature probe set-points.) This will only override off channels to on, it will not override on channels to off. Override period is fixed at 2 hours with a 5 minute warning before the override elapses.
Status 4	Entry point override	0Volt return	Operation is the exactly same as the Panel Override input
Status 5	Car Park Override	0Volt return	Only enabled when the store is unoccupied, this input will force the car park lights on for the duration of the parameter "Override On Period"
Status 6	Data manager Alarm	0Volt return	This input should be connected to an Alarm Relay on the Data Manager. When the store is unoccupied, a signal on this input will bring the car park lights on after the "Car Park Delay after Alarm" period has elapsed. The lights will stay on for the "Override On Period" and then go off.
mA input 1	Car-park light sensor	4-20mA loop	This input is used (when the timer is on) to switch the car park channel on and off according to light level. There is also an option to use this input in conjunction with the signage channel.
mA input 2	Internal light sensor	4-20mA loop	This input is used (when the timer is on) to switch the internal light channel (relay 12) on and off according to light level.
Analogue 1	Internal probe 1	PT1000	This input in conjunction with internal probe 2 is used to determine when the AC1 output is switched on. There are 2 x day set-points (min/max) and 2 out of hours set-points (min/max). The internal program uses which ever probe has the highest value to control the AC1 output. If the temperature is inside the min/max limits, the AC output will be off, if the temperature is outside of the min/max limits, the AC output will be on. Note: if both probe 1 and probe 2 are switched off by their parameters, the AC1 channel will follow the timing of stage 2 or if AC1 has been selected "by heating" the channel will follow the heating timer. This is not its normal operation, normal operation is by the use of a least 1 probe. If no probes are fitted, AC1 will not be on during the night and may result in high ambient temperatures within the store.
Analogue 2	Internal probe 2	PT1000	Operation is as above
Analogue 3	External probe	PT1000	Not used
Analogue 4	Internal Probe for AC2	PT1000	This input is used for the thermostat function of AC2, if the probe is switched off, the AC2 channel will follow the AC2 timer.
Analogue 8	Test Mode	Ov Return	Connect an 0V return to this input to force the controller into "Test" mode. Refer to the T-600 maintenance manual for the test instructions.



Ensure that all power is switched off before installing or maintaining this product

## Parameters: Screen Shot

Parameter	Value	Unit	Parameter	Value	Unit
Lights Stage 1 Off Delay	05:00	min:sec	Car Park Setpoint	300.0	Lux
Car Park Sensor Diff	150.0	Lux	AC 1 Day High Setting	23.0	Deg. C
AC 1 Day Low Setting	20.0	Deg. C	AC 1 Night High Setting	23.0	Deg. C
AC 1 Night Low Setting	20.0	Deg. C	AC2 High Setting	23.0	Deg. C
AC2 Low Setting	20.0	Deg. C	Internal Photocell Setpoint	300.0	Lux
Internal Sensor Diff	150.0	Lux	Air Curtain Uses Heatpump	Off	
RLY12 Internal Lights Option	Off		Shopfloor Probe 1	On	
Shopfloor Probe 2	Off		External Probe	Off	
AC 2 Probe	Off		Car Park Photocell	Off	
Signage uses Car Park Photocell	Off		Internal Photocell	Off	
AC 1 uses Heating Times	Off		Car Park Override On Period	01:00	hrs:min
Probe 1 Cal Value	0.0	Deg. C	Probe 2 Cal Value	0.0	Deg. C
AC2 Probe Cal Value	0.0	Deg. C	External probe Cal Value	0.0	Deg. C
24-7 Trading	Off		Frost Stat Setpoint	3.0	Deg. C
Heating Channel controls AHU	On		Divorce Feature Channel	Off	
Divorce Softdrinks Channel	Off		Divorce Relay12	Off	
AC1 Cools Only	On		Disable Season Change	Off	
Advance Season	Off				

## Parameters Description

Parameter	Description	Range	Units	Default	Comment
Lights Stage 1 Off Delay	Keeps stage 1 lights on after the panel input changes to loop on (unoccupied)	0 - 15	Mins	5	
<del>Car park - Perimeter Off delay</del>	<del>Keeps the car park lights on for this duration after either the timer goes off or the store becomes unoccupied</del>	<del>0 - 15</del>	<del>Mins</del>	<del>5</del>	This is now a fixed 5 minute period, and works only when the store becomes unoccupied
Car Park setpoint	Light level when the car park lights go off.	0 - 1400	Lux	300	Detects when its light
Car Park Sensor Diff	Diff below the set-point for the light sensor	0 - 300	Lux	150	Detects when its dark
AC 1 Day High Setting	AC1 turns on above this value during the occupied period	21 - 27	°C	23	
AC 1 Day Low Setting	AC1 turns on below this value during the occupied period	15 - 23	°C	20	
Parameters cont....					
AC 1 Night High Setting	AC1 turns on above this value during the unoccupied period	18 - 27	°C	23	
AC 1 Night High Setting	AC1 turns on below this value during the unoccupied period	10 - 23	°C	20	
AC 2 High Setting	AC 2 turns on above this setting	18 - 25	°C	23	
AC 2 Low Setting	AC 2 turns on below this setting	15 - 21	°C	20	



Ensure that all power is switched off before installing or maintaining this product

AC Stage 2 Override Delay	Delay time before the override starts	0-3	mins	4	
Internal Photocell Setpoint	Set point for the internal photocell	0 - 1400	Lux	300	Detects when its light
Internal Sensor Diff	Diff below the set-point for the light sensor	0 - 300	Lux	150	Detects when its dark
Air Curtain uses Heatpump	Links the channel to the internal thermostat function	On - Off		Off	
RLY 12 Internal Lights Option	Relay 12 mode, lights with internal photocell or Alarm relay	On - Off		Off	On = Lights Off = Alarm
Shop-floor Probe 1	Selects the probe	On - Off		Off	
Shop-floor Probe 2	Selects the probe	On - Off		Off	
External probe	Selects the probe	On - Off		Off	
AC 2 Probe	Selects the probe	On - Off		Off	
Car Park Photocell	Selects the photocell	On - Off		Off	
Signage uses car park sensor	Selects the car park sensor to control the signage channel	On - Off		Off	
Internal Photocell	Selects the photocell	On - Off		Off	
AC 1 uses Heating times	This allows the AC relay to be controlled via the heating timer	On - Off		Off	Allows AC 1 to come on before occupancy
Car Park Delay after Alarm	Sets the delay, after receiving a Data Manager Alarm input, before the car park lights come on	00:00-04:00	Hrs:Mins	00:45	
Car park Override On period	Sets the period for the car park lights on after receiving a Data Manager Alarm or a car park override input.	00:00 - 05:00	Hrs:Mins	01:00	
Probe 1 Cal Value	Allows for calibration of the probe	-10 to +10	°C	0	
Probe 2 Cal Value	Allows for calibration of the probe	-10 to +10	°C	0	
AC2 Probe Cal Value	Allows for calibration of the probe	-10 to +10	°C	0	
External probe Cal Value	Allows for calibration of the probe	-10 to +10	°C	0	
24-7 Trading	Setting Yes, inhibits the "Unoccupied Signal Not Used" Alarm	Yes No		No	
Frost Stat Setpoint	Setting for the heating channel to come on if outside of its timer	-10 to +10	°C	3	
Heating Channel Controls AHU	If set to on, the heating channel is used to switch an AHU, the setpoints for the AHU are the same as the AC1 settings				
Divorce Feature Channel	Allows the channel timer to be used outside of stage 1 and stage 2	Yes No		No	
Divorce Softdrinks Channel	Allows the channel timer to be used outside of stage 1 and stage 2	Yes No		No	Divorce Softdrinks
Divorce Relay 12	Allows the channel timer to be used outside of stage 1 and stage 2	Yes No		No	
AC1 Cools Only	Stops AC1 coming on when below the lower setpoint	Yes No		No	
Disable season Change	Stops the summer season disabling the feature channel	Yes No		No	
Advance Season	Use this to set the correct season	Yes No		No	



Ensure that all power is switched off before installing or maintaining this product

## Setting Up

This controller has to be “set-up” to function correctly, follow the set-up procedures below: -

1. Connect the controller to a PC using the USB cable.
2. Set up the local GP timers; see appendix 1
3. Set the parameters to the required settings according to the store type and installation
4. Log it on to the Data Manager
5. Setup the Data Manager GP timers; see appendix 2
6. Calibrate the probes



Ensure that all power is switched off before installing or maintaining this product

## Specification

### Power requirements:

Supply Voltage Range:	24 Vac $\pm 10\%$ or 24 Vdc $\pm 10\%$
Supply Frequency:	50 – 60 Hz $\pm 10\%$
Maximum supply current:	<1 Amp
Typical supply current:	0.3 Amp
Class 2 Insulation:	<b>No</b> protective Earth is required. A functional earth can be connected if the equipment is located in an electrically noisy environment.

**Note : The use of centre tapped to earth transformers is not allowed.  
This is to prevent damage to the transformer and/or controller.**

The host equipment must provide adequate protection against contact to hazardous live parts.

**RDM advise the use of a suitable external over-current protection device on the Mercury Plant Controller.**

Warranty may be invalidated due to excess current being unlimited if there are no fuses/circuit breakers installed

### General

Operating temperature range:	-10°C to +60°C
Operating Humidity:	80% maximum
Storage temperature range:	-20°C to +65°C
Environmental:	Indoor use at altitudes up to 2000m, Pollution Degree 1, Installation Category II.
	Voltage fluctuations not to exceed $\pm 10\%$ of nominal voltage
Size:	Mercury Plant Controller 270mm (L) x 115mm (W) x 50mm (H) Intuitive Plant Controller 280mm (L) x 122mm (W) x 67mm (H)
Weight:	Mercury Plant Controller 700 Grams Intuitive Plant Controller 750 Grams
Safety:	EN61010
EMC:	EN61326; 1997 +Amdt. A1; 1998
Ventilation:	There is no requirement for forced cooling ventilation

### Inputs

**Probe Input type** See [Set/change Units](#) for probe types

**Digital Input type** The preferred option is a 0 volt return through a volt free relay or 24 Vac referenced to the supply voltage. If a 24Vac signal is being sourced from the Plant controller power supply then **do not** ground the Digital Input common rail, this is grounded internally.

**Comms:** Ethernet

**4-20mA** 4-20mA current loop, use the 12 Vdc output to feed the device.

**Analogue Outputs** 0 to 10 Volts DC or 0/4-20mA, Selected in the Front Panel Menu.  
A 50mA fuse is recommended for each Analogue output.

The 4-20mA output will not operate correctly if the target device input impedance is > 75 $\Omega$

The 0-10V output will not operate correctly if the target device input impedance is < 10K $\Omega$

### Relay Ratings, Mercury Plant Controller

5A/250 Vac/AC1 (Resistive load)  
5A/30 Vdc (Resistive load)  
2A/250 Vac  $\cos\phi=0.3$  on N/O contact (Inductive Load)

### Relay Ratings, Intuitive Plant Controller

10A/250 Vac/AC1 (Resistive load)  
10A/30 Vdc (Resistive load)  
5A/250 Vac  $\cos\phi=0.4$

### Fuse Ratings, Intuitive Plant Controller

Relay Fuses 10A Antisurge HRC, 32 x 6.3mm  
Supply Fuse 2A Antisurge HRC, 32 x 6.3mm



Ensure that all power is switched off before installing or maintaining this product

## Software, Software drivers and software features and function licenses

RDM product Software Licences and drivers are non-transferable. They are purchased with hardware or separately and once added to hardware for use on that hardware only. If hardware is returned and deemed out of warranty all software driver licences terminate with the hardware.

### Installation:

#### Mounting on to a DIN rail, Mercury Plant Controller

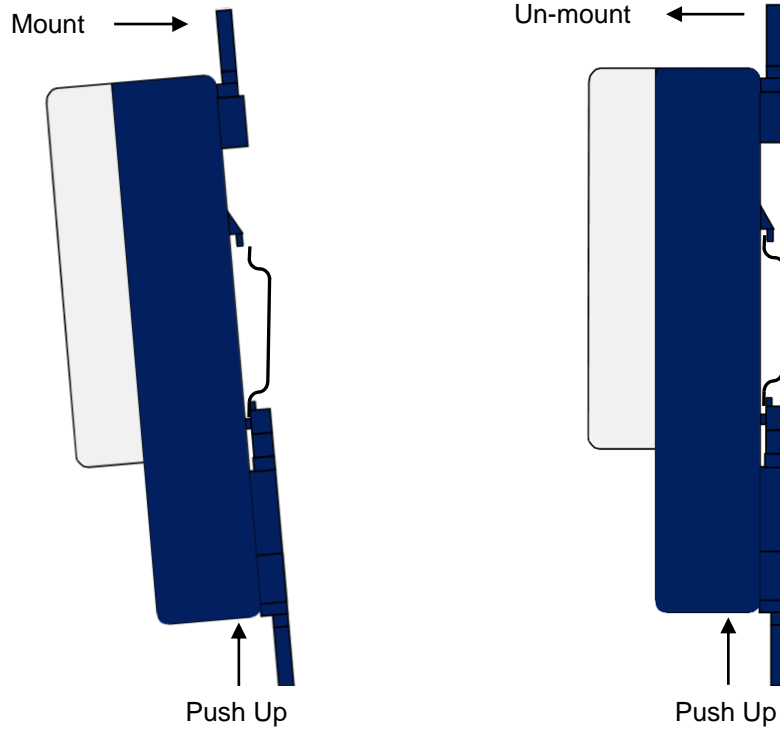

Ensure that all power is switched off before installing or maintaining this product

## Mounting on a DIN rail, Intuitive Plant Controller

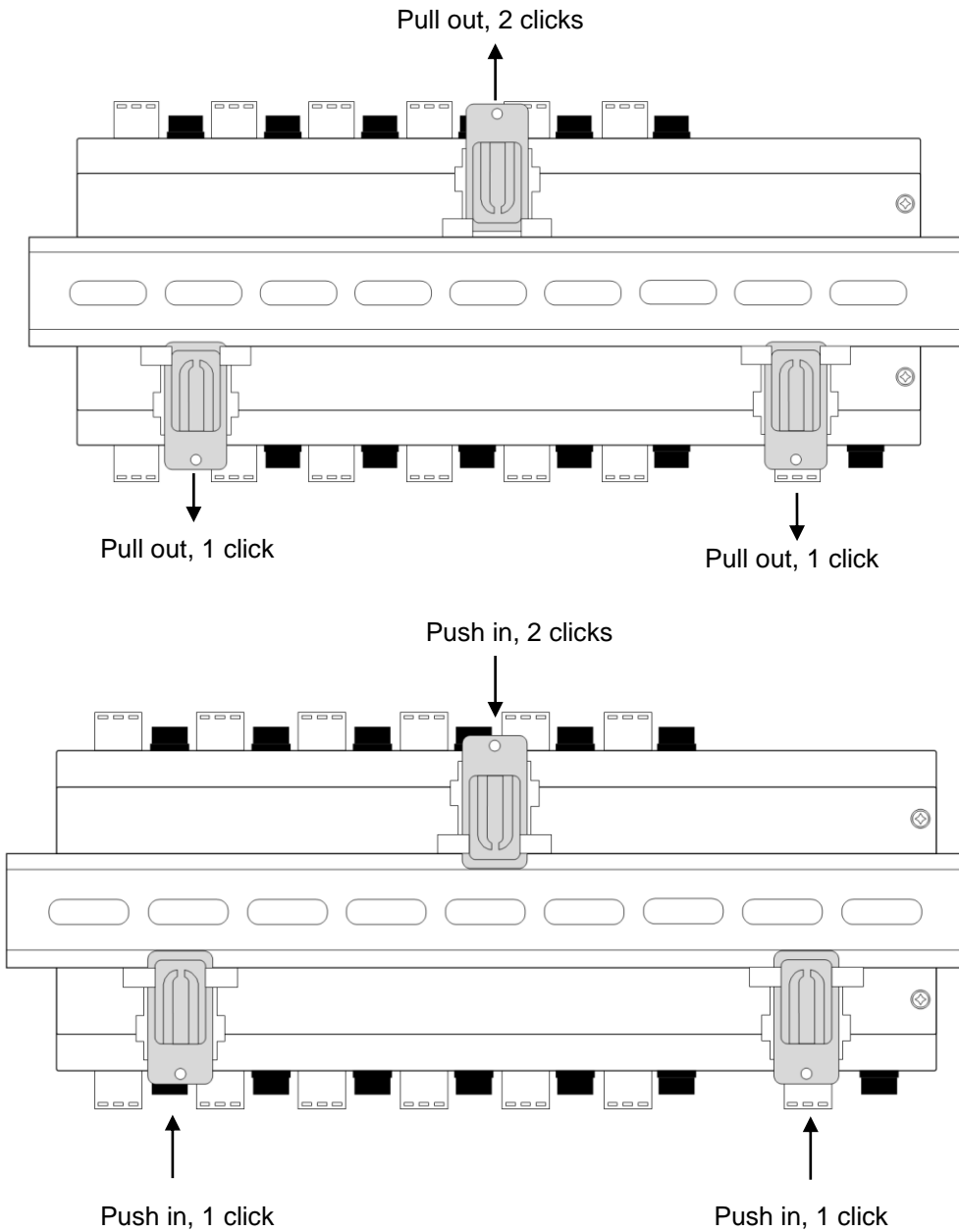

The Intuitive plant controller has three DIN rail mounting feet which can slide in and out to three different positions, sliding into each position is accompanied by a “click” which locks the foot into that position. To install the controller onto a DIN mounting rail, from the fully pushed in position slide the top mounting foot out by 2 clicks so that the foot is clear of the DIN rail channel. Slide the bottom two feet out by one click so that they are protruding slightly into the DIN rail channel. The controller can now be inserted onto the DIN rail by inserting the bottom lip of the DIN rail behind the two bottom mounting feet

The controller can now be pushed flat onto the DIN rail and the top foot pushed in 2 clicks to hold the controller in place. Finally, push the bottom two feet in by one click to secure the controller.

The mounting feet also have M3 holes for direct mounting where DIN rail is not being used.

### Clearances:

The controller must have 10mm clearance above the top and 15mm clearance from the sides. Clearance at the front and rear is dependent on the site wiring. There is no requirement for forced cooling ventilation

### Cleaning:

Do not wet the controller when cleaning. Clean the front by wiping with a slightly dampened lint free cloth.

**Please note: The specifications of the product detailed on this set up guide may change without notice. RDM Ltd shall not be liable for errors or for incidental or consequential damages, directly or indirectly, in connection with the furnishing, performance or misuse of this product or document.**



Ensure that all power is switched off before installing or maintaining this product

## Appendix 1 Setting Local GP Timers

The following local GP Timers within the PR0600-TDB-ENG must be set: -

GP Timer Channel 2	Store Trading Times
GP Timer Channel 3	Signage Lighting Times
GP Timer Channel 4	Car Park Lights Times
GP Timer Channel 5	Heating Times
GP Timer Channel 6	BWS area Lights Times
GP Timer Channel 7	AC 2 Times
GP Timer Channel 8	Feature Lights
GP Timer Channel 9	Softdrinks
GP Timer Channel 10	Relay 12
GP Timer Channel 11	Frost Stat
GP Timer Channel 12	Season Change

Note: Normally channel 2 timer will be set as a “master channel” with the other channels as “slaves”

To set the channels times, click the “Add Schedule” button and follow the wizard.

Channels (relays) that do not have a dedicated Timer will follow the “Store Trading Times” GP Timer Channel 2

Below are screen shots of the PR0600-TDB\_ENG GP timer pages when viewed from a PC connection: -

### GP Channels page

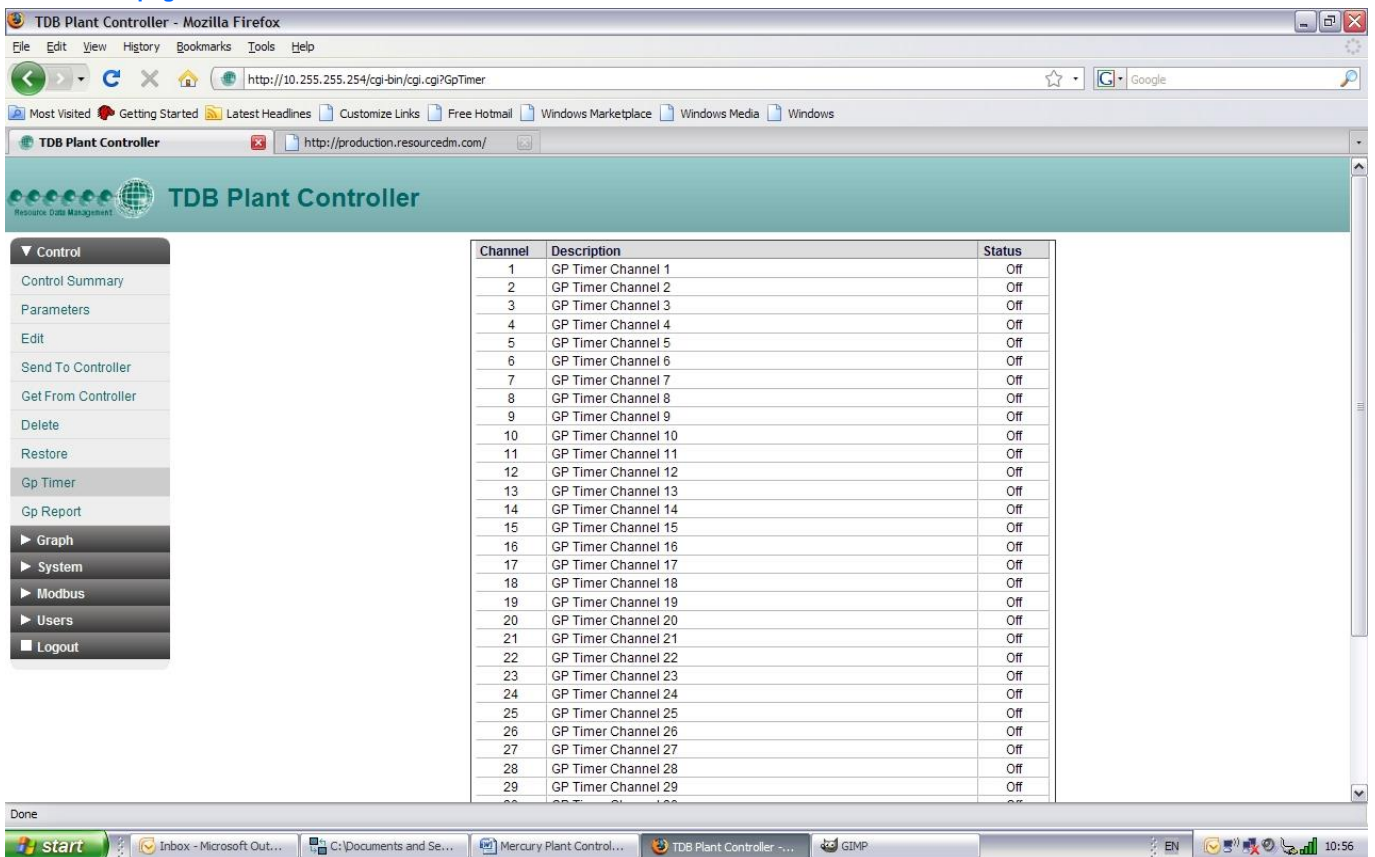

Ensure that all power is switched off before installing or maintaining this product

## GP Channel as a Master

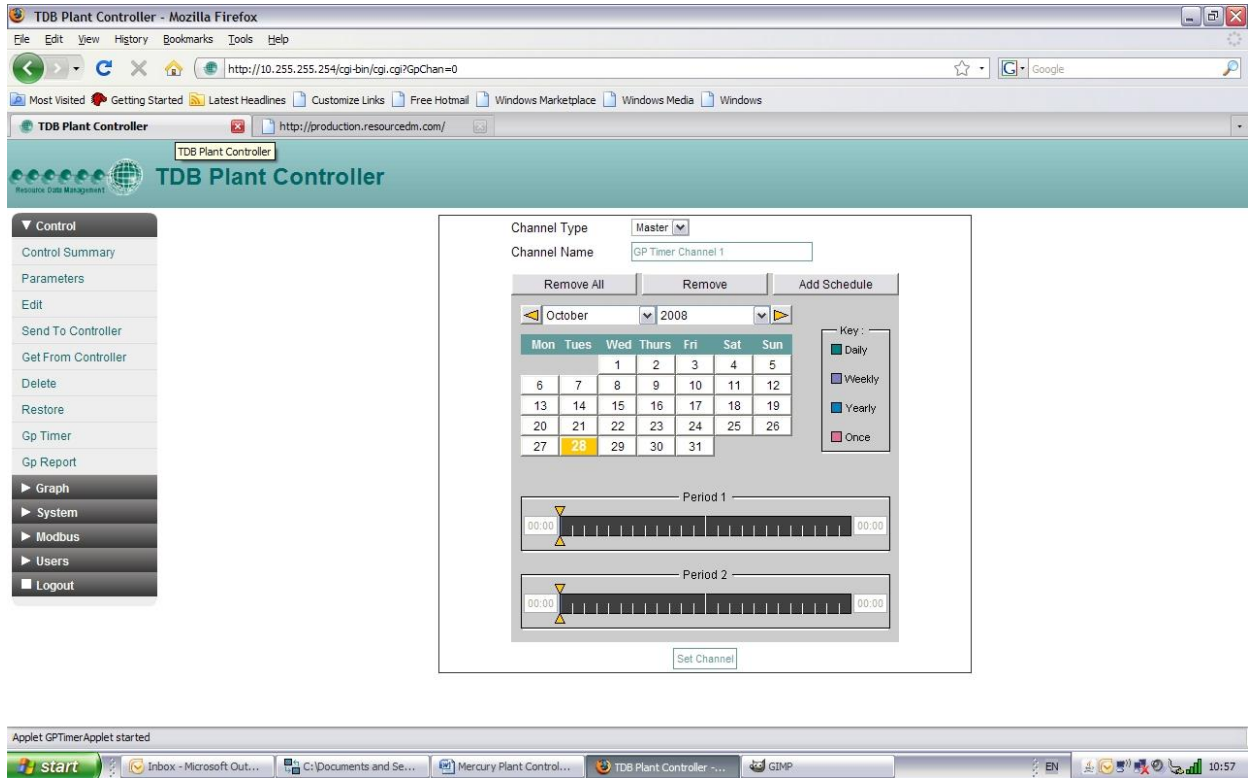

The screenshot shows the TDB Plant Controller web interface in Mozilla Firefox. The main content area displays the configuration for a GP Channel as a Master. The Channel Type is set to 'Master' and the Channel Name is 'GP Timer Channel 1'. There are buttons for 'Remove All', 'Remove', and 'Add Schedule'. A calendar for October 2008 is shown with a key for scheduling: Daily (dark blue), Weekly (light blue), Yearly (medium blue), and Once (red). Below the calendar are two time period sliders, 'Period 1' and 'Period 2', both set to 00:00. A 'Set Channel' button is at the bottom.

Applet GPTimerApplet started

## GP Channel as a Slave

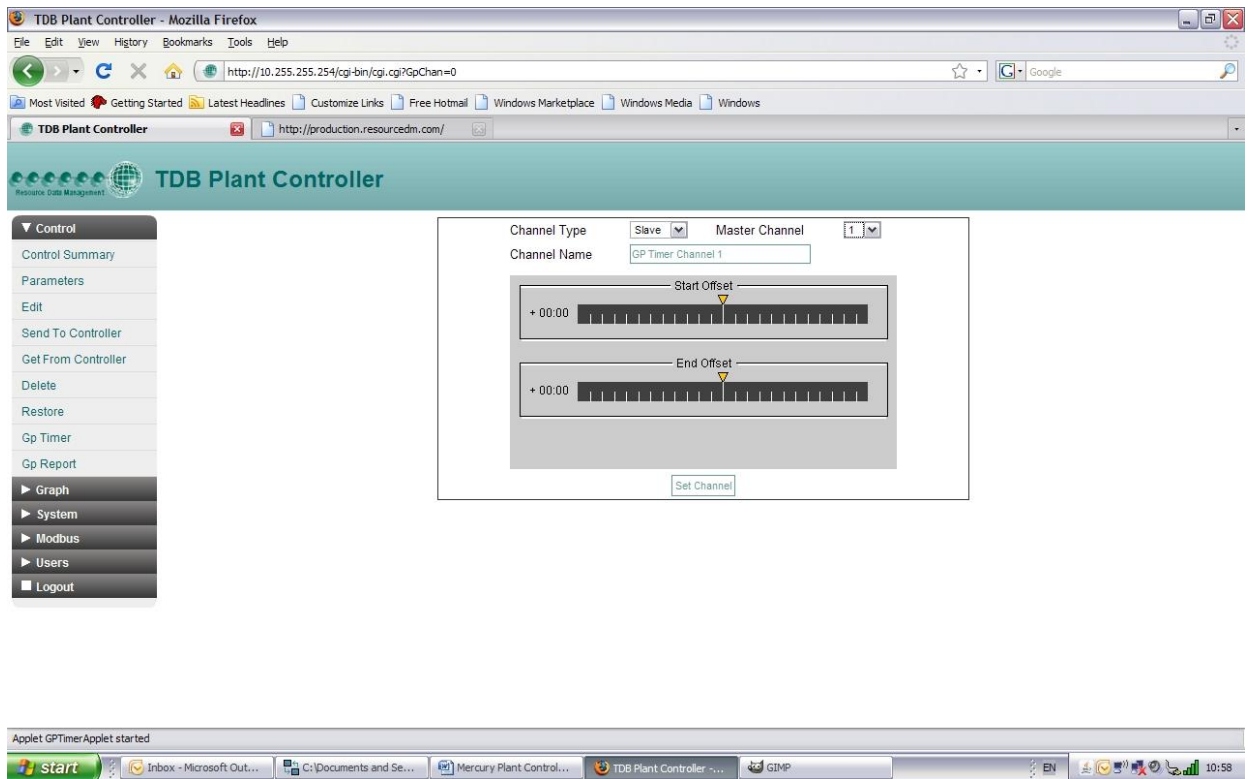

The screenshot shows the TDB Plant Controller web interface in Mozilla Firefox. The main content area displays the configuration for a GP Channel as a Slave. The Channel Type is set to 'Slave' and the Master Channel is '1'. The Channel Name is 'GP Timer Channel 1'. There are two time offset sliders, 'Start Offset' and 'End Offset', both set to + 00:00. A 'Set Channel' button is at the bottom.

Applet GPTimerApplet started



Ensure that all power is switched off before installing or maintaining this product

## Appendix 2 Remote Data Manager GP Timers

The following remote GP timers within the Data Manager must be set: -

General Note; -

The Output Type must be set to "General"

The Output Mask set to the controller name (T-600, is generally used)

The Output Channel set to the number indicated below: -

GP Timer Channel 17	Store Trading Times	Output Channel 17
GP Timer Channel 18	Signage Lights Times	Output Channel 18
GP Timer Channel 19	Car park Lights Times	Output Channel 19
GP Timer Channel 20	Heating Times	Output Channel 20
GP Timer Channel 21	BWS Area Lights Times	Output Channel 21
GP Timer Channel 22	AC 2 Times	Output Channel 22
GP Timer Channel 23	Feature Lights	Output Channel 23
GP Timer Channel 24	Softdrinks Area	Output Channel 24
GP Timer Channel 25	Relay 12	Output Channel 25
GP Timer Channel 27	Frost Stat	Output Channel 26
GP Timer Channel 28	Season Change	Output Channel 27

Note that any GP channel can be used, the important data is the controller name and the output channel number.

Follow the guidelines in the Data Manager User guide to set up GP timer channels.

### Disclaimer

The specifications of the product detailed in this document may change without notice. RDM Ltd shall not be liable for errors or omissions, for incidental or consequential damages, directly or indirectly, in connection with the furnishing, performance or misuse of this product or document.



Ensure that all power is switched off before installing or maintaining this product

## Appendix 3 – Supply & Status Input Wiring

Appendix four applies to the current version of the Plant controller hardware.

- Method 1. Not Valid for this controller
- Method 2. Uses a 0V return (from the status connector) to the status signal input.
- Method 3. Not valid for this controller

All transformers that have a connection to the Plant Controller must have their primaries connected to the same phase. Transformer should have fuse fitted in line with 24V input as per diagram.

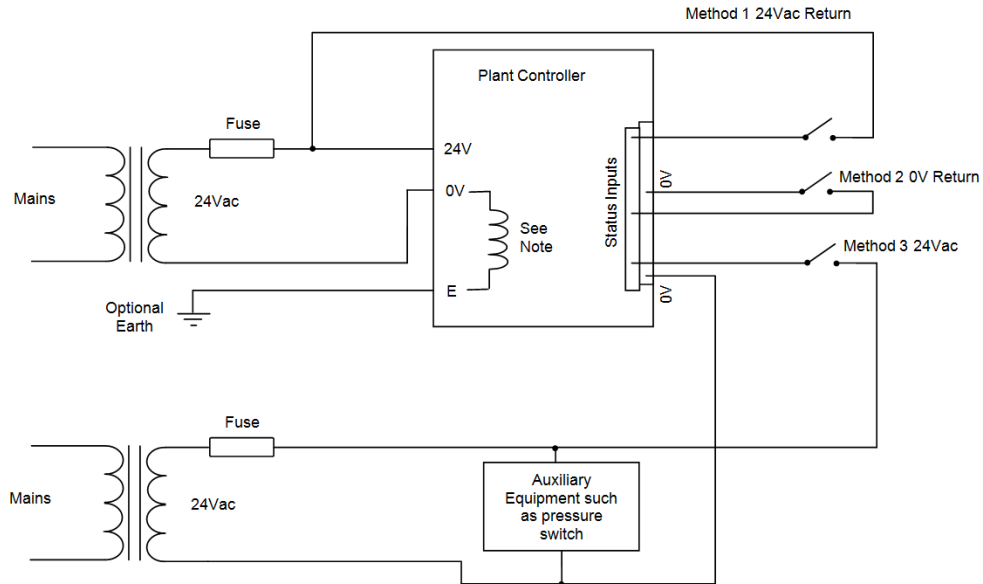

Note: For older versions of hardware (Software V1.6 or earlier). Please see separate data sheet.

**The use of centre tapped to earth transformers is not allowed. This is to prevent damage to the transformer and/or controller**



Ensure that all power is switched off before installing or maintaining this product

## Revision History

Revision	Date	Author	Changes
1.0	11/08/2008	NJ	1 <sup>st</sup> Issue
1.1	28/10/2008	NJ	Appendix 2 and 3 added, parameter changes made
1.2	30/10/2008	NJ	GP channel outputs corrected from 12 – 16 to 17 - 21
1.3	04/12/2008	NJ	Light sensor parameters changed from % to Lux. Additional info added for the GP timers. Sensors diff changed to lux.
1.4	14/04/2009	NJ	AC Low operational limits changed to 18 – 23, new parameter added to allow the signage channel to use the car park sensor.
1.5	28/04/2009	NJ	Car park channel now switches on without stage 1
1.6	13/05/2009	NJ	Car Park now has an override input and will also respond to a Data Manager Alarm input. Both new options are only active when the store is unoccupied.
1.7	22/06/2009	NJ	Added an optional thermostat function to the over-door channel
1.8	25/06/2009	NJ	AC night default temps changed to be the same as day settings
1.9	24/08/2009	NJ	AC 2 now has its own GP timer and thermostat function (using probe 4), it no longer follows AC 1. Heating output no longer requires stage 1 to be on to run (allows the heating to come on before occupancy)
5.0	14/10/2009	NJ	Harmonised the software revision with the document revision (5.0). Added a probe calibration parameter to all 4 probes. Removed the USB to PC connection guide section (this can now be found in a separate document on the RDM website)
5.5	04/12/2009	NJ	Alarm added to detect "Unoccupied not used", Inhibit added if the store trades 24-7. Feature timer and softdrinks timer added Local GP 8 & 9, remote 23 & 24. Photo sensor zero level changed to 3.5 mA (after testing an actual sensor)
5.7A	24/05/2010	NJ	Softdrinks and Feature channels have a parameter to divorce from stage 1&2 (switches purely on times). Software Version is now indicated on the "values" page. Thermostat function added to the heating channel. Improved description of AC1 probe use.
5-7-3	15/07/2010	NJ	New parameter added to allow the car park auto off feature to be inhibited; this allows the channel to respond to the timer only.
5-7-4	03/11/2010	NJ	Added a frost stat and timer to the heating channel, added an example of a Data Manager GP timer set-up. Timer state table now shows remote/local and on/off. Added a divorce feature to the Relay 12 channel. AC1 thermostat now uses the average of Probe 1 and 2 and not the max. Alarm time for "unoccupied not used" increased to 1 hour.
6-0	04/10/2011	NJ	Summer/Winter Seasons added to disable the feature channel during the summer. Heating channel change to have an "AHU" option. AC1 change to allow for "cooling only" Heating channel thermostat removed, linked to AC1. Operational flow diagrams removed from document. Document style change to new Intuitive type.
6.0A	16/02/2012	EM	Current Issue
6.0B	06/01/2015	SG	Operating temperature range updated.



Ensure that all power is switched off before installing or maintaining this product