



Mercury
PR0710-IOR



Intuitive
PR0750-IOR

Mercury 2 & Intuitive Mercury I/O Module Installation & User Guide

Resource Data Management

UK OFFICE

Resource Data Management Ltd
80 Johnstone Avenue,
Hillington Industrial Estate,
Glasgow, Scotland, G52 4NZ, UK
☎ +44(0)141 810 2828
✉ sales@resourcedm.com

US OFFICE

Resource Data Management Inc
100 North Sixth Street,
Suite 820C,
Minneapolis, MN 55403, USA
☎ Tel +1 612 354 2923
☎ Fax +1 612 208 0922
✉ usasales@resourcedm.com

Table of Contents:

THE MERCURY & INTUITIVE I/O MODULE..... 3

Description 3

 Variants 3

Configuration 3

Compatible Network Interfaces 3

Front Display Features 4

Connections 4

Mercury Mk2 4

Intuitive Mercury Controller Intuitive Mercury Network Expansion Options 5

Input and Output Allocation Tables 5

 Input / Output allocation table 5

 Switched Resistor Values 5

Setting up the controller 6

 Setup through front buttons 6

 Setup Function Menu 6

Recommended set-up method 6

 rtc. Real time clock (This will automatically synchronise on network systems) 6

 PArA. Set/view parameters (This can be achieved at the network front end) 6

 Unit. Set/view temperature unit and Probe type 6

 Probe Types 7

Parameter Tables 7

Network Configuration 7

 IP Futura module / Intuitive Internal IP Network card 7

Mercury Switch 8

Normal Operation 8

Viewing 9

Input / Output Table 9

 Remote commands 9

 Probe Offset 9

Specification 10

 Power requirements 10

 General 10

 Relay Specification 10

 Inputs 11

Switched Resistor Example Wiring 11

Installation 11

Dimensions 11

 Fixing 11

Dimensions 12

 Intuitive Mercury Mounting Instructions 12

 Cleaning 12

Disclaimer 12

REVISION HISTORY..... 13



Ensure that all power is switched off before installing or maintaining this product

The Mercury & Intuitive I/O Module

From Resource Data Management

Description

The Mercury 2 & intuitive Mercury Monitor is intended for use with the Data Builder Program to access networked I/O. There is no functional program inside the I/O module, its inputs and outputs are all available to be used as remote I/O by the Data Builder running on a Data manager (See Controller Editor in appendix 1).

Each input has to be locally configured before use, see parameter table for set-up options.
When an input is configured for probe use, a switched resistor can be used as a digital switch on that channel.

The Intuitive Mercury range is designed to be used in a control panel or electrical tray. This range has the same features as the Mercury Mk2 controller with additional benefits such as higher rated relays each protected by an integral fuse and fuse protection for the incoming power supply and all connections are plug in socket. .

The monitor supports the following probe types, PT1000, NTC470R, NTC700R, NTC2k, NTC2k25, NTC3k, NTC5k, NTC6k or NTC10K.

Variants

Description	Part Number
Mercury Mk2, I/O Module	PR0710-IOR
Intuitive Mercury, I/O Module	PR0750-IOR

Configuration

The controller is delivered pre-configured with all 6 input channels configured as PT1000 probes.

Compatible Network Interfaces

The Mercury and Intuitive Mercury I/O module requires connection to a TCP/IP local area network in order to communicate with the Data Manager. To connect to a network you must add the correct communications module. Connecting to any of these communication modules will automatically be detected on power up and will affect the set up screens available to you.

Description	Part Number
IP Futura (Single Mercury to IP Interface)	PR0016
Mercury IP Switch (IP support for 10 controllers)	PR0018
Mercury IP Switch with Pressure/Humidity Inputs	PR0018-PHI

The Intuitive Mercury Controller is supplied as standard with an internal RS232 network card, this allows connection to any of the above external network interfaces. Alternatively, an internal network card can be supplied factory fitted as an option or purchased separately as an interface kit.

Description	Part Number
Intuitive Internal IP Network Card Interface Kit	PR0770



Ensure that all power is switched off before installing or maintaining this product

Front Display Features

LED's: -

Valve (Not Used)

Fans (Not Used)

Lights (Not Used)

Defrost

On-Line

- Off No network attached
- Flashing Attempting to Log on to network
- Steady On-line

Service (Not Used)

Alarm

HACCP (Not Used)



Keys

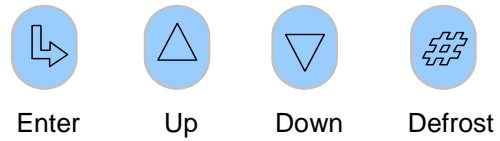

Note: Function keys illuminate when pressed, illumination is turned off 20 seconds after the key is used. Press and hold the defrost button to force a manual defrost

Main Display



4 character LED display, used to display time and status messages.

Note the Intuitive Mercury display is Green in colour when lit.

Connections

Mercury Mk2

Input and Output connections are made to the back of the controller, the RS232 communication port is on the side. The diagram shows the connection detail. Inputs and outputs are assigned according to the chosen configuration. See [Input/Output](#) tables for further details on connections.



Do not connect an earth.

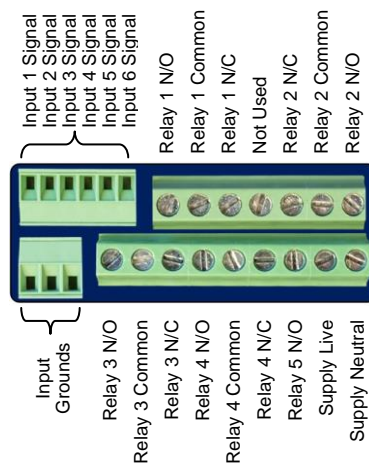

Ensure that all power is switched off before installing or maintaining this product

Intuitive Mercury Controller

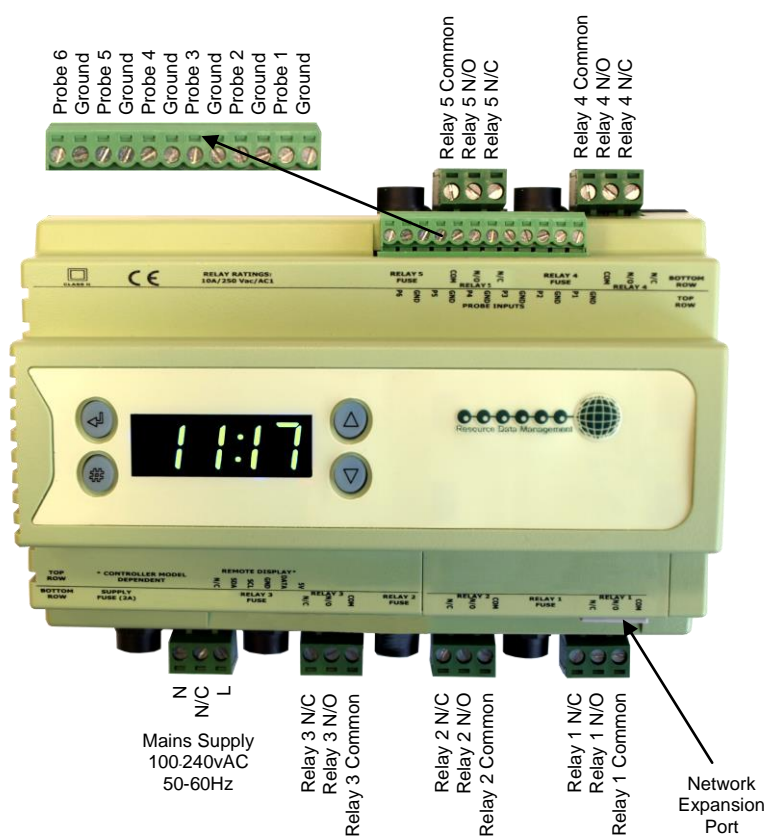

Intuitive Mercury Network Expansion Options

RS232 Network Card (Default)

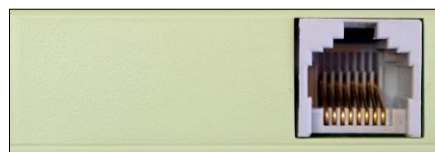

The Intuitive Mercury is supplied with an RS232 Network Card fitted as standard. Some example optional network cards are shown below

IP Network Card (PR0770)



Rotary Address Switches, Network Collision LED, Network Activity LED

All inputs and outputs are plug and socket. The supply voltage and relay outputs have individual fuse protection.

Input and Output Allocation Tables

The following tables indicate; on a controller type basis, the functions of the inputs and outputs. Also shown are the defrost inputs that are derived by switching in a fixed value resistor across the input.

Input / Output allocation table

	Description	Alarm Action	Switch Function (resistor*)
Probe 1	Probe 1 or Plant Fault	Probe 1	Yes, when in probe mode
Probe 2	Probe 2 or Plant Fault	Probe 2	Yes, when in probe mode
Probe 3	Probe 3 or Plant Fault	Probe 3	Yes, when in probe mode
Probe 4	Probe 4 or Plant Fault	Probe 4	Yes, when in probe mode
Probe 5	Probe 5 or Plant Fault	Probe 5	Yes, when in probe mode
Probe 6	Probe 6 or Plant Fault	Probe 6	Yes, when in probe mode
Relay 1	Relay with Common, N/O & N/C	N/A	N/A
Relay 2	Relay with Common, N/O & N/C	N/A	N/A
Relay 3	Relay with Common, N/O & N/C	N/A	N/A
Relay 4	Relay with Common, N/O & N/C	N/A	N/A
Relay 5	Relay with Common, N/O & N/C Intuitive model only	N/A	N/A
Relay 5	N/O relay (outputs the supply voltage) Mercury Mk2 Model Only	N/A	N/A

- PT1000 temperature range is -42°C to +128°C

Switched Resistor Values

For PT1000 probes, use 820 Ohm switched resistors
 For NTC470R and NTC700R probes, switch resistor features are not available
 For NTC 2k, NTC2k25, NTC3K use 590 Ohm switched resistors
 For NTC5k, NTC6k and NTC10K Use 2k7 Ohm switched resistors
 The resistors used must have a tolerance of 1% or better and the resistor must have a power rating of 0.25W. For improved accuracy whilst using switched resistors RDM recommend resistors with 0.1% accuracy are used.

Relays 1 to 4 : (Software) Outputs shows Off = Relay Energised
 Relay 5 : (Software) Outputs shows Off = Relay De-Energised

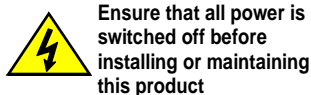

Setting up the controller

Access to the controller can be achieved several ways

- Through the front mounted buttons
- Direct access by PC or palm top into the rear comms port. This requires a software package available on the RDM website
- Through the RDM Data Manager.
- Across an IP network. (Current controller IP address required)

Setup through front buttons



To enter setup mode, hold the Enter and Down buttons together for approximately 3 seconds until the message “Ent” appears on the display. Now press the Enter button again to enter the function menu. IO will be displayed. Scroll up or down to go through the list.

Setup Function Menu

Display	Option	Explained in Paragraph	Display	Option	Explained in Paragraph
IO	View Inputs / Outputs and States	Input / output table	nEt	Set/view network configuration	Network Configuration
PArA	Set/View Parameters	Set view parameters	SoFt	View software version	
Unit	Probe type and Celsius/Fahrenheit option	Set View Unit	OFSt	Probe Offset	Probe Offset
Rtc	Set/view Clock (rtc = Real Time Clock)	Real Time Clock	ESC	Exit Setup mode	

Recommended set-up method

If you are not connecting to a network and want to set up the controller through the buttons we recommend you use the following order from the function menu.

rtc. Real time clock (This will automatically synchronise on network systems)

- Use the up or down buttons to scroll through the display until the display reads “rtc”
- Press enter. The display will show “t-1”. press enter again
- Scroll hours up or down (0 – 23) press enter
- Use up button to select “t-2”, press enter
- Scroll minutes up or down (0 – 59) press enter
- Repeat for t-3 (seconds 0 – 59)
- Repeat for t -4 (Days up to 31)
- Repeat for t -5 (months up to 12)
- Repeat for t -6 (Year up to 99)
- Use up button to display “ESC”, press enter to display “rtc”

Time clock is now set

PArA. Set/view parameters (This can be achieved at the network front end)

- From the function menu scroll to select PArA
- Pressing Enter while PArA is displayed will enter the parameter menu. The first parameter option will be displayed as P-01. Pressing the Up or Down button will present the other parameter options P-11, P-21 etc. See the parameter list below to find what parameter number corresponds to which actual parameter. Pressing the Enter button will show the current value of the selected parameter. Press Up or Down to modify the value and press Enter again to save the value. The parameter list number will be displayed again. Two other options are present in the parameter menu – dFLt and ESC. Selecting ESC will exit setup mode. Selecting dFLt will reset all parameters back to the default values for the current type of controller.

Unit. Set/view temperature unit and Probe type

From the function menu scroll to select Unit
Press enter and the value will be displayed: -



Ensure that all power is switched off before installing or maintaining this product

Probe Types

- | | | |
|-------------------------|---------------------------|--------------------------|
| 0 for PT1000 Celsius | 6 for 700R Celsius | 12 for 5K Celsius |
| 1 for PT1000 Fahrenheit | 7 for 700R Fahrenheit | 13 for 5K Fahrenheit |
| 2 for NTC2K Celsius | 8 for 3K Celsius | 14 for 6K Celsius |
| 3 for NTC2K Fahrenheit | 9 for 3K Fahrenheit | 15 for 6K Fahrenheit |
| 4 for 470R Celsius | 10 for NTC2K25 Celsius | 16 for NTC10K Celsius |
| 5 for 470R Fahrenheit | 11 for NTC2K25 Fahrenheit | 17 for NTC10K Fahrenheit |

Use the up or down keys to select the units and press enter.

This function is now complete

Parameter Tables

Number	Parameter	Range °C (°F)	Step	Units	Default
P-01	Input Type Channel 1	0 = Probe 1 = Plant N/C 2 = Plant N/O	1	Degrees N/A N/A	0
P-11	Input Type Channel 1	0 = Probe 1 = Plant N/C 2 = Plant N/O	1	Degrees N/A N/A	0
P-21	Input Type Channel 1	0 = Probe 1 = Plant N/C 2 = Plant N/O	1	Degrees N/A N/A	0
P-31	Input Type Channel 1	0 = Probe 1 = Plant N/C 2 = Plant N/O	1	Degrees N/A N/A	0
P-41	Input Type Channel 1	0 = Probe 1 = Plant N/C 2 = Plant N/O	1	Degrees N/A N/A	0
P-51	Input Type Channel 1	0 = Probe 1 = Plant N/C 2 = Plant N/O	1	Degrees N/A N/A	0

Network Configuration

The final section to setup is the network address. In all instances, this must be done before the controller is plugged into the site network. The controllers have an auto-initialise function, which will automatically log the device onto the site network. If the wrong address has been entered onto the network, you will have to reset the controller address by setting the address to 00-0, and then re-enter the correct address. (You may have to deregister the wrong address from the home system as well).

When logging a Mercury or Intuitive Mercury with an RS232 interface onto a network you must first connect the controller to a communications module, this is either an IP Futura or Mercury Switch. When using an Intuitive Mercury controller, the controller has to have the correct network card fitted (see “compatible network interfaces”). For connection to a Mercury Switch (Hub) or an external network interface, the standard fitment RS232 network card is utilized.

IP Futura module / Intuitive Internal IP Network card

In an IP system there are two options,

- IP-L
- IP-r

IP-L allows you to fix an IP address into the controller, which you would use when you are connecting the controllers onto a customer’s local area network. This would allow the customer to view each controller using Internet Explorer

IP-r allows you to give each controller on the system a unique number. This number is then allocated a dynamic IP address by the system DHCP server (such as the RDM Data Manager or Data Director)

IP-L

To configure the communication module or network card for IP-L, set all three rotary switches to zero. The module should then be connected to the controller. In the case of an Intuitive Mercury controller where the network card is already fitted, the controller should be powered off, all three rotary switches set to zero and the controller powered on.

1. nEt. From the function menu you can now select nEt
 - Press enter and the display will show “IP-L”, press enter



Ensure that all power is switched off before installing or maintaining this product

- You can now set the address using the table below

Display	Option
IP-1	IP Address byte 1
IP-2	IP Address byte 2
IP-3	IP Address byte 3
IP-4	IP Address byte 4
nL	Network Mask Length
gt-1	Gateway Address byte 1
gt-2	Gateway Address byte 2
gt-3	Gateway Address byte 3
gt-4	Gateway Address byte 4
ESC	Exit network menu. N.B. this option must be selected to save any changes made in this menu

IP-r

To configure the communication module for IP-r, set the three rotary switches to give each controller a unique identifier. The module should then be connected to the controller and the network. In the case of an Intuitive Mercury controller where the network card is already fitted, the three rotary switches must be set when the controller is powered off, the controller should then be powered on to connect to the network.

- nEt. From the function menu you can now select nEt
 - Press enter and the display will show "IP-r", press enter
 - You can now view only the address given by the DHCP server

To ease setup, a single network mask length value is used. If the address has been specified with a network mask value in dotted IP format e.g. 255.255.255.0 then the table below gives the conversion:

Mask	Length	Mask	Length	Mask	Length
		255.255.254.0	23	255.254.0.0	15
255.255.255.252	30	255.255.252.0	22	255.252.0.0	14
255.255.255.248	29	255.255.248.0	21	255.248.0.0	13
255.255.255.240	28	255.255.240.0	20	255.240.0.0	12
255.255.255.224	27	255.255.224.0	19	255.224.0.0	11
255.255.255.192	26	255.255.192.0	18	255.192.0.0	10
255.255.255.128	25	255.255.128.0	17	255.128.0.0	09
255.255.255.0	24	255.255.0.0	16	255.0.0.0	08

Mercury Switch

Please refer to the Mercury Switch user guide, which can be obtained from the RDM website, for information regarding connecting a controller to a network.

Normal Operation

During normal operation, the controller will display the current time, if there are no alarms and no defrost actions. If the Monitor is on a network and on-line, the green network LED will be on.



The Network green LED flashes if the controller goes off-line or loses its given address.



Ensure that all power is switched off before installing or maintaining this product

Viewing

Apart from setting up the controller, you can also view the status of the inputs and outputs and controller states. From the function menu, select "I/O", press enter. You can now scroll through the IO table as set out below.

Input / Output Table

Number	IO	Range
I-01	Input 1	
I-02	Input 2	
I-03	Input 3	
I-04	Input 4	
I-05	Input 5	
O-01	Relay 1	0 = off, 1 = on
O-02	Relay 2	0 = off, 1 = on
O-03	Relay 3	0 = off, 1 = on
O-04	Relay 4	0 = off, 1 = on
O-05	Relay 5	0 = off, 1 = on

Remote commands

Values for analogue input block values:

Probe 1 *returns probe 1 value*
 Probe 2 *returns probe 2 value*
 Probe 3 *returns probe 3 value*
 Probe 4 *returns probe 4 value*
 Probe 5 *returns probe 5 value*
 Probe 6 *returns probe 6 value*

Values for Digital Input (Plant) fault values:

Plant 1 *returns Plant 1 status*
 Plant 2 *returns Plant 2 status*
 Plant 3 *returns Plant 3 status*
 Plant 4 *returns Plant 4 status*
 Plant 5 *returns Plant 5 status*
 Plant 6 *returns Plant 6 status*

Values for digital input (switch) values:

Switch 1 *returns Switch 1 status*
 Switch 2 *returns Switch 2 status*
 Switch 3 *returns Switch 3 status*
 Switch 4 *returns Switch 4 status*
 Switch 5 *returns Switch 5 status*
 Switch 6 *returns Switch 6 status*

Send values to "Control State"

0 for Normal
 1 for Amber (defrost) LED
 2 for Red (alarm) LED
 3 for Amber and Red LED's on

Values for Digital Output values *

Remote Relay 1 *controls relay 1*
 Remote Relay 2 *controls relay 2*
 Remote Relay 3 *controls relay 3*
 Remote Relay 4 *controls relay 4*
 Remote Relay 5 *controls relay 5*

* Note: Relays 1, 2, 3 & 4 are energised when software state for that relay shows off.
 Relays 5 is not energised when software state for that relay shows off.

Probe Offset

This feature allows each probe value to be modified by an "offset". Offset values are from -10°C (-18°F) to +10°C (+18°F) and on a channel basis. Example C1 = Probe 1.



Ensure that all power is switched off before installing or maintaining this product

Specification

	Mercury Mk2 Controller PR0710-IOR	Intuitive Mercury controller PR0750-IOR
Power requirements		
Supply Voltage Range	100 - 240 Vac $\pm 10\%$	100 - 240 Vac $\pm 10\%$
Supply Frequency	50 - 60 Hz	50 - 60 Hz
Maximum supply current	5.2 Amps (when relay 5 is fully loaded)	2 Amps
Typical supply current	<1 Amp	<1 Amp
General		
Operating temperature range	+5°C to +50°C	-10°C to +60°C
Storage temperature range	-20°C to +65°C	-20°C to +65°C
Environmental	Indoor use at altitudes up to 2000m, pollution degree 1, installation category II. Voltage fluctuations not to exceed $\pm 10\%$ of nominal voltage.	Indoor use at altitudes up to 2000m, pollution degree 1, installation category II. Voltage fluctuations not to exceed $\pm 10\%$ of nominal voltage.
Size	78mm (W) x 36mm (H) x 110mm (D)	157mm (W) x 67mm (H) x 120 (D)
Approx Weight	170 grams	500 grams
Safety	EN61010	EN61010
EMC	EN61326; 1997 +Amdt. A1; 1998	EN61326; 1997 +Amdt. A1; 1998
Ventilation	There is no requirement for forced cooling ventilation	There is no requirement for forced cooling ventilation
Class 2 Insulation	No protective Earth is required and none should be fitted	No protective Earth is required and none should be fitted
Supply Fuse	The host equipment must provide a suitable external over-current protection device such as: - Fuse: 6.3A 240 Vac Antisurge (T) HRC conforming to IEC 60127	Built in fuse holder, fuse 2A 240Vac Antisurge (T) HRC conforming to IEC60127, 32 x 6.3mm
Or MCB	6A, 240 VAC Type C conforming to BS EN 60898	2A, 240 VAC Type C conforming to BS EN 60898 (Note: controller has integral 2A fuse)
Relay Fuse	Not Fitted	10A 240Vac Antisurge (T) HRC conforming to IEC60127, 32 x 6.3mm
Relay Specification		
Relays 1-4 Mechanical Type (M) Exclusive common		
Max current	6A Resistive (Cos ϕ = 1) 2A Inductive (Cos ϕ = 0.4)	.10A Resistive (Cos ϕ = 1) 3A Inductive (Cos ϕ = 0.4)
Max voltage	250Vac, 30V dc	250Vac, 30V dc
Relay Fuse	N/A	10A 240Vac Antisurge (T) HRC conforming to IEC60127, 32 x 6.3mm
Relay 5 Mechanical Type (M) Common connected to supply live		Relay 5 Mechanical Type (M) Exclusive common
Max current	3A (non inductive), COS ϕ =0.4 2A (inductive load) 200,000 operations	10A Resistive (Cos ϕ = 1) 3A Inductive (Cos ϕ = 0.4)
Max voltage	250Vac (Internal supply)	250Vac, 30V dc (external supply)
	For compliance with the LVD, relays 3, 4 and 5 commons must be at the same potential as the supply voltage	All relays are independent and can operate at different potentials to the supply voltage.



Warning: Relay 5 output has hazardous voltages (Supply input voltage potential)
This does not apply to the Intuitive Mercury controller



Ensure that all power is switched off before installing or maintaining this product

Inputs

Input resistance: 3.01K Ohms (for PTC or NTC type probes)
 Input type: PT1000 or NTC2K or NTC2K25 or NTC10K (selectable)
 Comms: RS232 with flow control

Switched Resistor Example Wiring

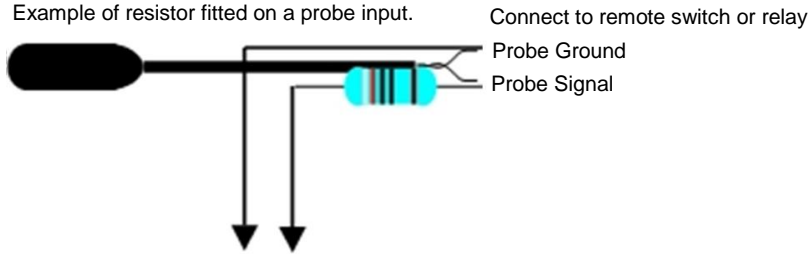

Installation

Panel Cut-out and Clearances

Mercury Mk2 (Flush mount controller)

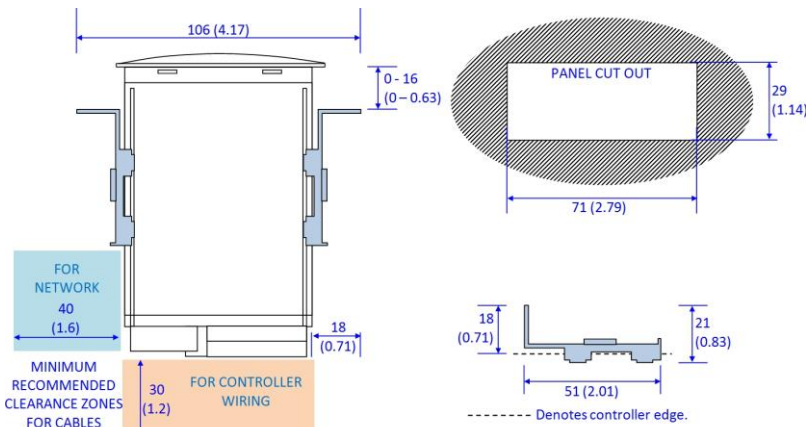

Fixing

The controller is fixed by sliding the 2 plastic retaining clips up to rear of the panel. These clips have a ratchet action and can be removed by holding in the clip sides and sliding back.

There is no requirement for forced cooling ventilation

Dimensions

Mercury Mk2

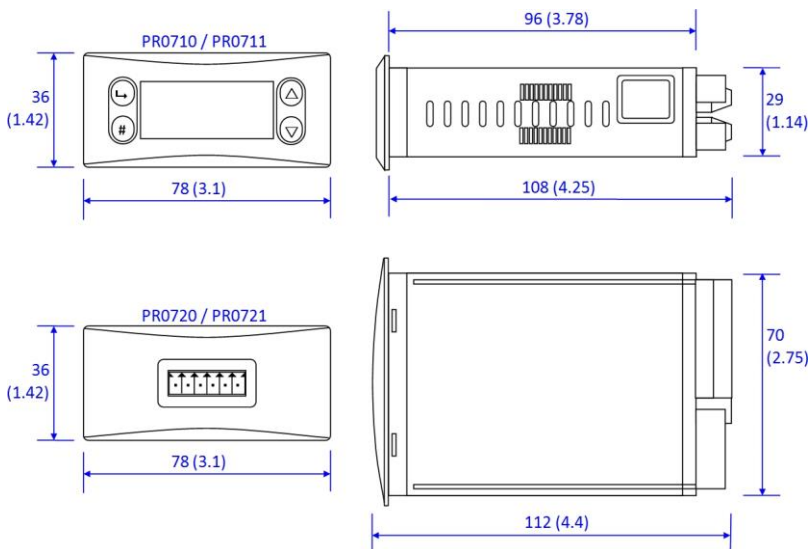

Ensure that all power is switched off before installing or maintaining this product

Dimensions

Intuitive Mercury controller

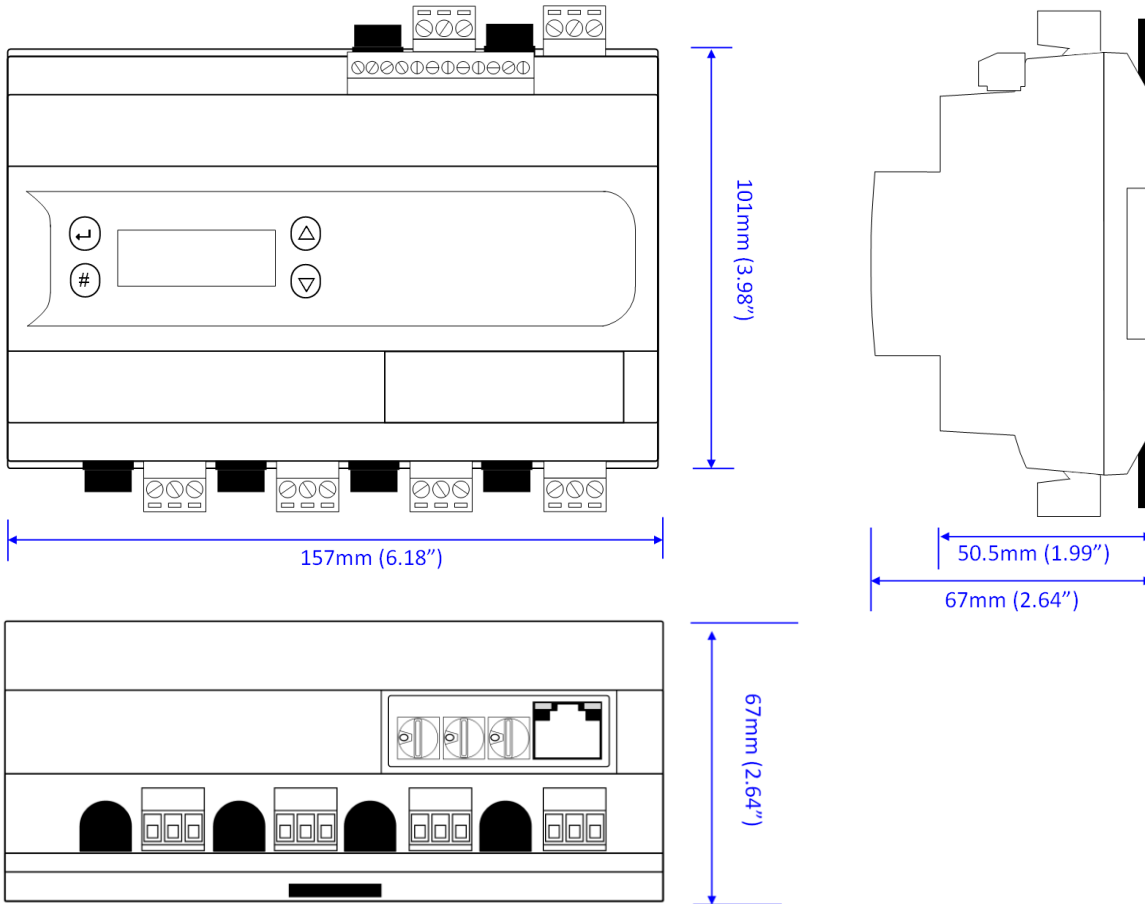

Intuitive Mercury Mounting Instructions

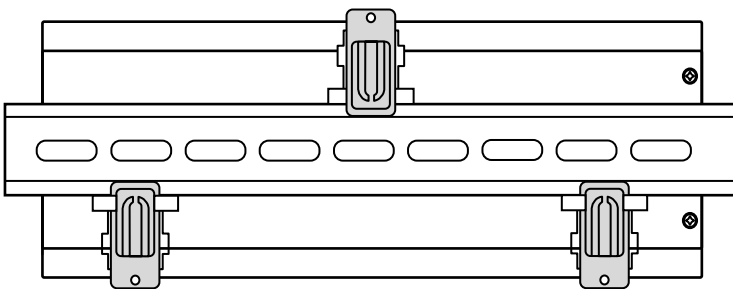

Three clips fix the Intuitive Mercury securely to DIN rail. Pull each clip until it “clicks” to remove the controller. Each clip has a mounting hole to provide an alternative fixing mechanism to DIN mounting.

Cleaning

Do not wet the controller when cleaning. Clean the front by wiping with slightly dampened lint free cloth.

Disclaimer

The specifications of the product detailed in this document may change without notice. RDM Ltd shall not be liable for errors or omissions, for incidental or consequential damages, directly or indirectly, in connection with the furnishing, performance or misuse of this product or document.



Ensure that all power is switched off before installing or maintaining this product

Revision History

Revision	Date	Changes
1.0	09/05/2011	Introduction of Intuitive range
1.3	20/02/2014	PT1000 temperature range is -42°C to +128°C
1.3a	06/01/2015	Operating temperature range updated



Ensure that all power is switched off before installing or maintaining this product