



Mercury

PR0710-TWI



Intuitive

PR0750-TWI

Mercury 2 & Intuitive Mercury Twin Coil Case Controller Installation & User Guide



Resource Data Management Ltd
80 Johnstone Avenue, Hillington Industrial Estate,
Glasgow, Scotland G52 4NZ UK
☎ +44(0)141 810 2828 Switchboard
✉ support@resourcedm.com Technical Support
✉ sales@resourcedm.com Sales Enquiries



Table of Contents:

THE MERCURY & INTUITIVE RANGE 4

 Description: 4

 Variants 4

Configuration 4

Compatible Network Interfaces 4

Front Display Features 5

Display Operation 5

Connections 6

 Mercury Mk2 6

 Intuitive Mercury Controller Intuitive Mercury Network Expansion Options 6

Input and Output Allocation Tables 7

 Input / Output allocation table 7

 Switched Resistor Values 7

Setting up the controller 7

 Setup through front buttons 7

 Setup Function Menu (Common to all types)..... 8

Recommended set-up method 8

 rtc. Real time clock (This will automatically synchronise on network systems) 8

 type. Set/view controller type 8

 PArA. Set/view parameters (This can be achieved at the network front end) 8

 Unit. Set/view temperature unit and Probe type 8

 Display..... 9

Parameter Tables 9

Parameter Descriptions 10

Maximum Operating Pressure (MOP) 12

Relay State and functional operation 12

Outputs and display states during defrost 12

 Defrost Termination..... 12

 Fan Delay after Defrost 12

Network Configuration 13

 RS485 Legacy module / Intuitive Internal RS485 Network card..... 13

 Wireless Mesh Communication Module..... 13

 Fast Network Address Reset 13

 IP Futura module / Intuitive Internal IP Network card 13

Mercury Switch 14

Viewing 14

 Input / Output Table 15

Display Messages..... 15

Network Alarms 16

Modifying controller states..... 16

 Fans Only “FAnS” 16

 Case Off “CASE” 16

 Lights Only “LitS” 16

 Probe Offset 16

 Operation 16

Remote Commands 17

 Power requirements 18

 General..... 18

 Relay Specification..... 18

Specification 18

 Inputs..... 19

Switched Resistor Example Wiring 19

Installation 19

Dimensions 19

 Fixing..... 19

Dimensions 20



Ensure that all power is switched off before installing or maintaining this product



Intuitive Mercury Mounting Instructions20
 Cleaning20
Disclaimer.....21
Appendix 1 Resistor Part Numbers21

APPENDIX 1 DEFROST CYCLES22

REVISION HISTORY.....22



Ensure that all power is switched off before installing or maintaining this product

The Mercury & Intuitive Range From Resource Data Management

Description:

This controller is primarily intended for use in 2 section (Twin Evaporators) refrigeration display cabinets, integrals or coldroom applications. It will switch the evaporator LLV / Compressors based on the value of its temperature probe inputs. There are 2 independent thermostat functions. Relays for 2 LLV's / Compressors and 2 defrost control relays. A single relay is provided for fan control.

The Intuitive Mercury range is designed to be used in a control panel or electrical tray. This range has the same features as the Mercury Mk2 controller with additional benefits such as higher rated relays each protected by an integral fuse and fuse protection for the incoming power supply, all connections are plug in socket. There are multiple network interfaces to choose from including Ethernet.

The controller supports PT1000, NTC2K, 470R, 700R, 3K, 5K, 6K, NTC2K25 NTC10K or NTC10K(2) temperature probes (note: probe types cannot be mixed)

Variants

Description	Part Number
Mercury Mk2 Two Section Controller.	PR0710-TWI
Intuitive Mercury Two Section Controller.	PR0750-TWI

Configuration

The controller gives you up to six configuration options: -

Display value	
1	Integral controller HT
2	Integral controller LT
3	Remote piped case controller LT
4	Remote piped case controller HT
5	Coldroom controller LT
6	Coldroom controller HT

Compatible Network Interfaces

Mercury and Intuitive Mercury controllers are capable of connecting to either a TCP/IP local area network, an RS485 Genus compatible network, an RDM wireless mesh network or they can be used in standalone mode with no network output. To connect to a network you must add the correct communications module. Connecting to any of these communication modules will automatically be detected on power up and will affect the set up screens available to you.

Description	Part Number
IP Futura (Single Mercury to IP Interface)	PR0016
RS485 Interface (Single Mercury to RS485 Interface)	PR0026
Mercury IP Switch (IP support for 10 controllers)	PR0018
Mercury IP Switch with Pressure/Humidity Inputs	PR0018-PHI
Wireless Mesh Interface (for single Mercury)	PR0730

The Intuitive Mercury Controller is supplied as standard with an internal RS232 network card, this allows connection to any of the above external network interfaces. Three alternative internal network cards are also available, these can be supplied factory fitted as an option or purchased separately as an interface kit.

Description	Part Number
Intuitive Internal IP Network Card Interface Kit	PR0770
Intuitive Internal RS485 Network Card Interface Kit	PR0771
Intuitive Internal Wireless Mesh Network Card Interface Kit	PR0772



Ensure that all power is switched off before installing or maintaining this product

Front Display Features

LED's: -

LLV (Relays 1 & 2)

Fans (Relay 3)

Lights (Not Used)

Defrost (Relays 4 & 5)

On-Line

Off No network attached
Flashing Attempting to Log on to network
Steady On-line

Service (See Parameter 18 for setup)

Alarm

HACCP



Keys

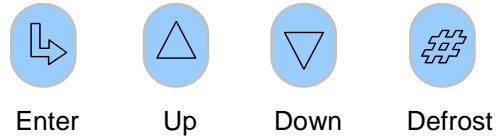

Note: Function keys illuminate when pressed, illumination is turned off 20 seconds after the key is used. Press and hold the defrost button to force a manual defrost

Main Display



4 character LED display, used to display temperature and status messages.

Note the Intuitive Mercury display is Green in colour when lit.

Display Operation

Left hand bar on display indicates which section temperature is currently being displayed.

Section 1 Temperature being displayed.



Section 2 Temperature being displayed.



Ensure that all power is switched off before installing or maintaining this product

Connections

Mercury Mk2

Input and Output connections are made to the back of the controller, the RS232 communication port is on the side. The diagram shows the connection detail. Inputs and outputs are assigned according to the chosen configuration. See [Input/Output](#) tables for further details on connections.

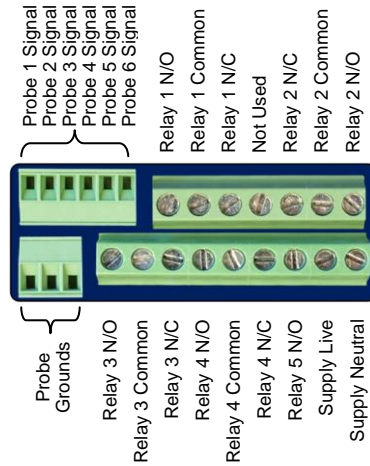

Intuitive Mercury Controller

Intuitive Mercury Network Expansion Options

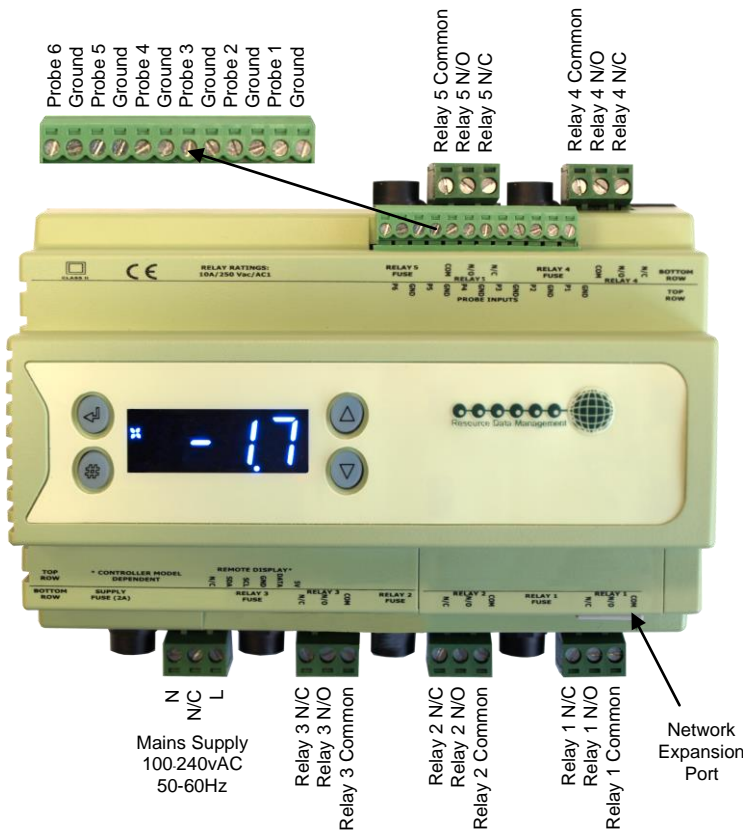

RS232 Network Card (Default)

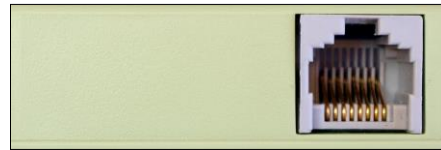

The Intuitive Mercury is supplied with an RS232 Network Card fitted as standard. Some example optional network cards are shown below

IP Network Card (PR0770)



Rotary Address Switches, Network Collision LED, Network Activity LED

RS485 Network Card (PR0771)



Ground, B-, A+, Screen, Network Activity LED

All inputs and outputs are plug and socket. The supply voltage and relay outputs have individual fuse protection.

PR0772 Wireless Mesh Option also available. The network interfaces work in the same way as there external counterparts.

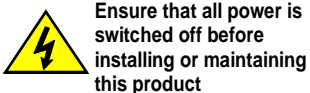

Input and Output Allocation Tables

The following tables indicate; on a controller type basis, the functions of the inputs and outputs. Also shown are the digital inputs that are derived by switching in a fixed value resistor across the input.

Input / Output allocation table

TYPE	Integral Case Types 1&2	Remote Case Types 3&4	Coldroom Controller Types 5&6	Alarm Action	Plant Input (Switched Resistors)
Input 1	Air on Section 1	Air on Section 1	Air on Section 1	Yes	
Input 2	Air off Section 1	Air off Section 1	Air off Section 1	Yes	Person trapped (Types 5&6)
Input 3	Defrost Section 1	Defrost Section 1	Defrost Section 1	No	Plant fault
Input 4	Air on Section 2	Air on Section 2	Air on Section 2	Yes	Case Clean
Input 5	Air Off Section 2	Air Off Section 2	Air Off Section 2	Yes	Plant fault 2 (Types 1&2) Door switch (Types 5&6)
Input 6	Defrost Section 2	Defrost Section 2	Defrost Section 2	No	
Relay 1	Section 1 Compressor (N/C)	Section 1 Liquid Line Valve (N/C)	Section 1 Liquid Line Valve (N/C)	N/A	
Relay 2	Section 2 Compressor (N/C)	Section 2 Liquid Line Valve (N/C)	Section 2 Liquid Line Valve (N/C)	N/A	
Relay 3	Fans (N/C)	Fans (N/C)	Fans (N/C)	N/A	
Relay 4	Defrost Section 1 (N/O)	Defrost Section 1 (N/O)	Defrost Section 1 (N/O)	N/A	
Relay 5	Defrost Section 2 (N/O)	Defrost Section 2 (N/O)	Defrost Section 2 (N/O)	N/A	

Switched Resistor Values

For PT1000 probes use 820 Ohm switched resistors.
 For NTC2K, NTC2K25 and 3K probes use 590 Ohm switched resistors.
 For 5K and 6K use 1K Ohm switched resistors.
 For NTC10K probes use 2k7 Ohm switched resistors.
 For NTC10K(2) probes use 2k2 Ohm switched resistors.

The resistors used must have a tolerance of 1% or better and the resistor must have a power rating of 0.25W. For improved accuracy whilst using switched resistors RDM recommend resistors with 0.1% accuracy are used. Note the switched resistor features will **not** function when using 470R or 700R probes. When a resistor is switched across the appropriate input it signals to the Mercury to enable the switched resistor function described for that input whilst still recording the probe temperature on the input.

Temperature range for all probe types is -49°C to +60°C for probe inputs which do not have a secondary function (switched resistors). Inputs which have a secondary function are restricted to -42°C to +60°C. If the full temperature range is required on all inputs and no switch resistor features are needed then please see Switch Resistor parameter P-19

Note: switched resistors will operate in LT (Low Temperature) and HT (High Temperature) applications using PT1000, NTC2K or NTC2K25 probe types only. For all other probe types the switched resistor inputs will work in HT applications only.

Setting up the controller

Access to the controller can be achieved several ways

- Through the front mounted buttons
- Direct access by PC or palm top into the rear comms port. This requires a software package available on the RDM website
- Through legacy front end panels on 485 networks
- Through the RDM Data Manager.
- Across an IP network. (Current controller IP address required)

Setup through front buttons



To enter setup mode, hold the Enter and Down buttons together for approximately 3 seconds until the message "Ent" appears on the display. Now press the Enter button again to enter the function menu. IO will be displayed. Scroll up or down to go through the list.



Ensure that all power is switched off before installing or maintaining this product

Setup Function Menu (Common to all types)

Display	Option	Explained in Paragraph	Display	Option	Explained in Paragraph
IO	View Inputs / Outputs and States	Input / output table	nEt	Set/view network configuration	Network Configuration
PArA	Set/View Parameters	Set view parameters	SoFt	View software version	
Unit	Probe type and Celsius/Fahrenheit option	Set View Unit	FANs	Toggle Fans Only mode	Fans
diSP	Display whole units or decimal	Display	CASE	Toggle Case Off mode	Case Off
tyPE	Set/View Controller Type	Set/view controller type	OFSt	Probe Offset	Probe Offset
rtc	Set/view Clock (rtc = Real Time Clock)	Real Time Clock	ESC	Exit Setup mode	

Recommended set-up method

If you are not connecting to a network and want to set up the controller through the buttons we recommend you use the following order from the function menu.

rtc. Real time clock (This will automatically synchronise on network systems)

- Use the up or down buttons to scroll through the display until the display reads “rtc”
- Press enter. The display will show “t-1”. press enter again
- Scroll hours up or down (0 – 23) press enter
- Use up button to select “t-2”, press enter
- Scroll minutes up or down (0 – 59) press enter
- Repeat for t-3 (seconds 0 – 59)
- Repeat for t -4 (Days up to 31)
- Repeat for t -5 (months up to 12)
- Repeat for t -6 (Year up to 99)
- Use up button to display “ESC”, press enter to display “rtc”
Timeclock is now set

type. Set/view controller type

- From the function menu scroll to select type, press enter
- Use the up/down buttons to scroll through case/coldroom configuration types. (see [configuration table on](#) page 4)
- Press enter.
- Scroll to select “ESC”
- Press enter

Controller type configuration is now set

PArA. Set/view parameters (This can be achieved at the network front end)

- From the function menu scroll to select PArA
- Pressing Enter while PArA is displayed will enter the parameter menu. The first parameter option will be displayed as P-01. Pressing the Up or Down button will present the other parameter options P-02, P-03 etc. See the parameter list below to find what parameter number corresponds to which actual parameter. Pressing the Enter button will show the current value of the selected parameter. Press Up or Down to modify the value and press Enter again to save the value. The parameter list number will be displayed again. Two other options are present in the parameter menu – dFLt and ESC. Selecting ESC will exit setup mode. Selecting dFLt will reset all parameters back to the default values for the current type of controller.

Unit. Set/view temperature unit and Probe type

From the function menu scroll to select Unit
Press enter and the value will be displayed: -

Probe Types

- | | |
|-------------------------|--|
| 0 for PT1000 Celsius | 10 for NTC2K25 Celsius |
| 1 for PT1000 Fahrenheit | 11 for NTC2K25 Fahrenheit |
| 2 for NTC2K Celsius | 12 for 5K Celsius |
| 3 for NTC2K Fahrenheit | 13 for 5K Fahrenheit |
| 4 for 470R Celsius | 14 for 6K Celsius |
| 5 for 470R Fahrenheit | 15 for 6K Fahrenheit |
| 6 for 700R Celsius | 16 for NTC10K Celsius |
| 7 for 700R Fahrenheit | 17 for NTC10K Fahrenheit |
| 8 for 3K Celsius | 18 for NTC10K(2) Celsius (USA NTC10K) |
| 9 for 3K Fahrenheit | 19 for NTC10K(2) Fahrenheit (USA NTC10K) |

Use the up or down keys to select the units and press enter.

This function is now complete



Ensure that all power is switched off before installing or maintaining this product

Display

From the function menu scroll to and select diSP.
 Press enter and one of the following values will be shown: -
 0. Controller display will show the whole number and tenths value of a temperature reading. (Default)
 1. Controller display will show temperatures as a whole number.
 Display defaults to 0.

Parameter Tables

Not all parameters apply to all controller types, for example P-68 is the section 1 anti short cycle time which applies to integral cases only (types 1 & 2), this parameter will not appear if the controller is set up as a type 3,4,5 or 6 (static case or coldroom). In the following table, the type columns on the right hand side will be greyed out if that parameter does not apply to that controller type.

Number	Parameter	Range °C (°F)	Step	Units	Default LT °C (°F)	Default HT °C (°F)	Type 1&2	Type 3&4	Type 5&6
P-11	Section 1 Cut-in Temp.	-42 to 30 (-43.6 to 86)	0.1	Deg	-20 (-4)	0.0 (32)		✓	✓
	Section 1 Cut-in Temp. (Integral)	-42 to 30 (-43.6 to 86)	0.1	Deg	-20 (-4)	3.5 (38.3)	✓		
P-12	Section 2 Cut-in Temp.	-42 to 30 (-43.6 to 86)	0.1	Deg	-20 (-4)	0.0 (32)		✓	✓
	Section 2 Cut-in Temp. (Integral)	-42 to 30 (-43.6 to 86)	0.1	Deg	-20 (-4)	3.5 (38.3)	✓		
P-13	Section 1 Diff.	0 to 10 (0 to 18)	0.1	Deg	2 (3.6)	1.5 (2.7)		✓	✓
	Section 1 Diff. (Integral)	0 to 10 (0 to 18)	0.1	Deg	2.5 (4.5)	2.5 (4.5)	✓		
P-14	Section 2 Diff.	0 to 10 (0 to 18)	0.1	Deg	2 (3.6)	1.5 (2.7)		✓	✓
	Section 2 Diff. (Integral)	0 to 10 (0 to 18)	0.1	Deg	2.5 (4.5)	2.5 (4.5)	✓		
P-30	Control Weight (section 1)	0 to 100	1	%	50	50		✓	✓
	Control Weight (section 1) (Integral)	0 to 100	1	%	40	30	✓		
P-32	Control Weight (section 2)	0 to 100	1	%	50	50		✓	✓
	Control Weight (section 2) (Integral)	0 to 100	1	%	40	30	✓		
P-31	Display Weight (section 1)	0 to 100	1	%	50	50		✓	✓
	Display Weight (section 1) (Integral)	0 to 100	1	%	40	30	✓		
P-33	Display Weight (section 2)	0 to 100	1	%	50	50		✓	✓
	Display Weight (section 2) (Integral)	0 to 100	1	%	40	30	✓		
P-68	Section 1 Anti SC Time	00:00 to 15:00	00:05	mm:ss	03:00	03:00	✓		
P-69	Section 2 Anti SC Time	00:00 to 15:00	00:05	mm:ss	03:00	03:00	✓		
P-85	Key-switch mode	0 = case off, 1 = fans only 2 = toggle	1		0	0	✓	✓	✓
P-90	Resistor Case Off	0 (Disabled), 1 (Enabled)			0	0	✓	✓	✓
P-19	Switch Resistors	0 (Off), 1 (On)	1		0	0	✓	✓	✓
P-97	Control Fail On/Off	00:00 to 10:00	0.1	Mm:ss	00:00	00:00	✓	✓	✓
P-18	Service Time	0 to 128	1	KHrs	60	60	✓	✓	✓
P-60	Sect 1 OT/UT Delay	00:00 to 99:00	01:00	mm:ss	20:00	20:00	✓	✓	✓
P-61	Sect 2 OT/UT Delay	00:00 to 99:00	01:00	mm:ss	20:00	20:00	✓	✓	✓
P-62	Sect 1 UT Alarm	-49 to 60 (-56.2 to 140)	0.1	Deg	-30 (22)	-2 (28.4)	✓	✓	✓
P-63	Sect 2 UT Alarm	-49 to 60 (-56.2 to 140)	0.1	Deg	-30 (22)	-2 (28.4)	✓	✓	✓
P-64	Sect 1 OT Alarm	-49 to 60 (-56.2 to 140)	0.1	Deg	-15 (5)	5 (41)	✓	✓	✓
P-65	Sect 2 OT Alarm	-49 to 60 (-56.2 to 140)	0.1	Deg	-15 (5)	5 (41)	✓	✓	✓
P-50	Fans in defrost	0 (Off), 1 (On)	1		0 (static) 1	0 (static) 1	✓	✓	✓
P-49	Fan Delay Time	00:00 to 99:00	01:00	mm:ss	00:00	00:00	✓	✓	✓
P-86	Fan Delay Mode	0 = Time 1 = Temp	1		0	0	✓	✓	✓
P-88	Fan Delay Temp	-42 to 30 (-43.6 to 86)	0.1	Deg	-20 (-4)	0.0 (32)	✓	✓	✓
P-92	Fan Temp Mode	0 = Off, 1 = Temp 2 = OT, 3 = Temp / OT	1		0	0	✓	✓	✓
P-93	Fans Off Temp	-42 to 30 (-43.6 to 86)	0.1	Deg	-10 (14)	8 (46.4)	✓	✓	✓
P-83	Fan Control	0 = Off, 1 = Run 2 = Pulse	1		1	1			✓
P-78	Fan Pulse On	00:00 to 99:00	01:00	mm:ss	05:00	05:00			✓
P-79	Fan Pulse Off	00:00 to 99:00	01:00	mm:ss	30:00	30:00			✓
P-40	Defrost Mode	0 (Local), 1 (Remote)			0	0	✓	✓	✓



Ensure that all power is switched off before installing or maintaining this product

Number	Parameter	Range °C (°F)	Step	Units	Default LT °C (°F)	Default HT °C (°F)	Type 1&2	Type 3&4	Type 5&6
P-41	Defrost Start	00:00 to 23:59	00:01	hh:mm	01:00	01:00	✓	✓	✓
P-42	Defrost Number	0 to 8	1		6	6	✓	✓	✓
P-43	No Defrost Time	0 to 180	1	hours	8	8	✓	✓	✓
P-66	Sect 1 Def Term	-42 to 30 (-43.6 to 86)	0.1	Deg	10 (50)	10 (50)	✓	✓	✓
P-67	Sect 2 Def Term	-42 to 30 (-43.6 to 86)	0.1	Deg	10 (50)	10 (50)	✓	✓	✓
P-45	Def Min Time	00:00 to 99:00	01:00	mm:ss	05:00	05:00	✓	✓	✓
P-46	Def Max Time	00:00 to 99:00	01:00	mm:ss	24:00	24:00	✓	✓	✓
P-47	Drain Down Time	00:00 to 24:00	00:15	mm:ss	01:30	01:30	✓	✓	✓
P-48	Recovery Time	00:00 to 99:00	01:00	mm:ss	30:00	30:00	✓	✓	✓
P-89	Pump Down Time	00:00 to 99:00	01:00	mm:ss	00:00	00:00	✓	✓	✓
P-94	Defrost Hold	0 (Off), 1 (On)			0	0	✓	✓	✓
P-95	Defrost Skip	0 (Off), 1 (On)			0	0	✓	✓	✓
P-96	Def Skip Time	00:00 to 99:00	01:00	mm:ss	12:00	12:00	✓	✓	✓
P-82	Door Stops Fans	0 = No. 1 = Yes							✓
P-80	Door Alarm delay	00:00 to 99:00	01:00	mm:ss	01:00	20:00			✓
P-81	Door Closes LL	0 = No. 1 = Yes							✓
P-77	Trap Stops LLV/Fans	0 (Off), 1(On)	1		0	0			✓
dFLt	Restore default values						✓	✓	✓

Parameter Descriptions

Number	Parameter	Description
P-11	Sect 1 Cut-In	Temperature at which section 1 LLV or Compressor will switch on.
P-12	Sect 2 Cut-In	Temperature at which section 2 LLV or Compressor will switch on.
P-13	Sect 1 Diff	Differential temperature below section 1 cut-in temperature. The LLV or compressor switches off when below this temperature
P-14	Sect 2 Diff	As above only applied to section 2
P-30	Sect 1 Ctrl Weight	Percentage of Section 1 Air-On temperature that is used to calculate the control temp. The remaining percentage will be used on the Air-Off temperature Example, P-30 set to 30% Control temp = 30% Air-on + 70% Air-off
P-32	Sect 2 Ctrl Weight	As above only applied to section 2 Control Temp
P-31	Sect 1 Display Weight	As above only applied to section 1 Display Temp
P-33	Sect 2 Display Weight	As above only applied to section 2 Display Temp
P-68	Sect 1 Anti Sc	Allows the user to set the compressor for a given number of starts/hour (The time set is the time between compressor starts)
P-69	Sect 2 Anti Sc	Allows the user to set the compressor for a given number of starts/hour (The time set is the time between compressor starts)
P-85	Key Switch	Allows the keys switch to be: - ➤ Single turn for case off (Case off mode) ➤ Single turn for Fans only (Fans Mode) Single turn for case off, double turn for fans only (Toggle mode)
P-90	Resistor Case Off	Turns on/off the switched resistor Case Off function
P-19	Switch Resistors	Allows option to uses switch resistors
P-97	Control Fail Valve Value	This value is used in the event of the control probes failing for either section; Please note the incorrect setting of this value may result in flood back causing damage to the pack compressors. Do not adjust this parameter if you are unsure of the consequences. This is the value to which the LLV/compressor relay will be pulsed open/closed. For example if set to 2 minutes then the LLV will be open for 2 minutes and then closed for two minutes. This process will continue until the control probe fail has been rectified for the given section.
P-18	Service Time	Time (in 1000 x hours) before the service icon (Spanner icon) comes on. Reset the spanner icon to off by changing this parameter to 0 and then back to the desired service interval.
P-60	Sect 1 OT/UT Delay	Delay for the over and under Temperature Alarms on Section 1
P-61	Sect 2 OT/UT Delay	Delay for the over and under Temperature Alarms on section 2
P-62	Sect 1 UT Alarm	Under temperature alarm set point for section 1. This alarm uses the control temperature.
P-63	Sect 2 UT Alarm	Under temperature alarm set point for section 2. This alarm uses the control temperature.
P-64	Sect 1 OT Alarm	Over temperature alarm set point for section 1. This alarm uses the air-off temperature.
P-65	Sect 2 OT Alarm	Over temperature alarm set point for section 2. This alarm uses the air-off temperature.
P-50	Fans In Defrost	Allows the user to set the fans on or off in defrost. Note if the fans are set to on in defrost, they will go off for the drain-down period and then follow the P-86 rules.
P-49	Fan Delay	Time after a drain-down period before the fans start if P-86 is set to time



Ensure that all power is switched off before installing or maintaining this product

Number	Parameter	Description
P-86	Fan Delay mode	This parameter allows the fans start after a drain-down period to be delayed, either by time (P-49) or when the temperature point (P-88) is reached. This parameter uses the same probe strategy as the defrost terminate.
P-88	Fan Delay Temp	Temperature at which the fans start after a drain-down period when P-86 is set to temperature.
P-92	Fan Temp Mode	Allows the user to set the fans to turn off when: - <ul style="list-style-type: none"> ➢ A pre-determined temperature is reached (P93) ➢ When an over-temperature alarm is present ➢ When either P93 is reached or an OT alarm is present
P-93	Fans Off Temp	Temperature for the above (P92) operation. Note the defrost termination probe is the source of the temperature reading used in this feature. If the defrost termination probe isn't fitted then a similar process to P-66/67 is used.
P-83	Fan Control	This feature allows for coldroom fans to be stopped when the coldroom is down to temperature thus saving energy. <ul style="list-style-type: none"> ➢ Run – fans operate as per the normal control strategy. ➢ Pulse – When the LLV closes the fans will stop when the Fan Pulse On parameter (P-78) time expires. The fans then remain off for the Fan Pulse Off time (P-79). When the parameter Fan Pulse Off time expires the fans come back on for the Fan Pulse On time. The cycle then repeats. The fans resume normal operation if the LLV operates. The fans pulse on/off to ensure the circulation of air within the coldroom. ➢ Off – When the LLV closes the fans stay on for the Fan Pulse On (P-78) time before going off until the LLV next operates. Placement of the temperature control probes is important when using this feature
P-78	Fan Pulse On	The duration the fans are pulsed on in Fan Control.
P-79	Fan Pulse Off	The duration the fans are pulsed off in Fan Control.
P-40	Defrost Mode	Allows the user to set the defrost mode: - <ul style="list-style-type: none"> ➢ Local (Uses the internal parameters P-41 and P-42) ➢ Remote (Requires a defrost schedule in the front end)
P-41	Defrost Start	When defrost mode is set to "Local", this is the start time for the 1 st defrost
P-42	Defrosts per Day	When defrost mode is set to "Local", this is the number of defrosts per day equally spaced from the start time.
P-43	No Defrost Time	If the controller misses a defrost command for any reason, a Defrost will initiate after this time has elapsed from the last defrost. Normally set to 2 hours over the normal defrost period. A missed defrost alarm will also be generated.
P-66	Sect 1 Def Term	The defrost for Section 1 will terminate (Defrost Heater Section 1 relay off) when the temperature of Section 1 defrost termination probe reaches this value. If Section 1 Defrost Termination probe is not fitted, defrost termination will occur when: - The "air off" probe reaches the set point. If the Air Off probe is faulty, termination will occur on time.
P-67	Sect 2 Def Term	The defrost for Section 2 will terminate (Defrost Heater Section 2 relay off) when the temperature of Section 2 defrost termination probe reaches this value. If Section 2 Defrost Termination probe is not fitted, defrost termination will occur when: - The "air off" probe reaches the set point. If the Air Off probe is faulty, termination will occur on time.
P-45	Def Min Time	Minimum time that a defrost will use (Defrost can't terminate until this time has elapsed. If termination temperature is reached during this period, the defrost control relay is turned off, but the controller will not continue the defrost cycle until the end of the defrost min period)
P-46	Def Max Time	Time period after defrost minimum that defrosts are allowed to terminate, if termination temperature is not reached then defrost will terminate after this period
P-47	Drain Down	A period after defrost max to allow the draining of any surplus water
P-48	Recovery Time	The LLV is switched on at the start of this period to allow the temperature to recover to the normal operating point. This period also inhibits the OT alarm. Note that if the air-off temperature is still above the OT alarm setpoint when this period expires, an immediate OT alarm occurs; there is not a further alarm delay.
P-89	Pump Down Time	Time period before the defrost min period to allow for a pump down
P-94	Defrost Hold	Turns the defrost hold feature on and off. When switched on, the controller can be held in defrost until a remote command from the front end starts the recovery process.
P-95	Defrost Skip	Allows user to enable/disable defrost skip. This feature allows the controller to skip defrosts. If the current defrost terminates on temperature then the controller will skip the next scheduled defrost providing the previous defrost terminated before the defrost skip time (P-96). Operates only when the controller is set to local defrost scheduling.
P-96	Defrost Skip Time	Time factor used in defrost skip. The previous defrost has to terminate before this value expires to allow the controller to skip a defrost.
P-82	Door Stops Fan	This parameter is used in coldroom applications to stop the fans if the door opens. If the door remains open then the fans will resume normal operation on the expiry of the door alarm delay (P-80).
P-80	Door alarm delay	Delay after the door open input is activated before the alarm occurs.
P-81	Door Closes Valve	This parameter is used in coldroom applications to close the LLV if the door opens. If the door remains open then the valve will resume normal operation on the expiry of the door alarm delay (P-80).
P-77	Man Stp LLV/Fans	When man trap input is activated the LLV closes and Fans are stopped. Normal operation resumes when the mantrap input is deactivated.
dFLt	Restore default values	Restores all of the parameters to their default values



Ensure that all power is switched off before installing or maintaining this product

Maximum Operating Pressure (MOP)

MOP is a remote command sent from the Mercury Switch (PR0018-PHI) to the controller to close LLVs when a predetermined pressure is reached. This MOP value is configured in the Mercury Switch setup. When the Mercury Switch generates the MOP alarm the LLVs are closed for the MOP alarm duration.

Relay State and functional operation

Relay 1-3 State	Function State	Wired contact
Relay 1 off	Section 1 LLV / Comp. On	N/C
Relay 1 on	Section 1 LLV / Comp. Off	N/C
Relay 2 off	Section 2 LLV / Comp. On	N/C
Relay 2 on	Section 2 LLV / Comp. Off	N/C
Relay 3 off	Fans on	N/C

Relay 4-5 State	Function State	Wired contact
Relay 3 on	Fans off	N/C
Relay 4 off	Defrost Heater 1 off	N/O
Relay 4 on	Defrost Heater 1 on	N/O
Relay 5 off	Defrost Heater 2 off	N/O
Relay 5 on	Defrost Heater 2 on	N/O

Outputs and display states during defrost

State:	Pump Down	Defrost Min	Defrost Max	Drain Down	Fan Delay	Recovery
Display:	DEF	DEF	DEF	DEF	DEF	REC
Def LED:	On	On	On	Off	Off	Off
Sect 1 LLV/Comp (Rly 1)	Closed/Off	Closed/Off	Closed/Off	Closed/Off	Open/On	Open/On
Sect 2 LLV/Comp (Rly 2)	Closed/Off	Closed/Off	Closed/Off	Closed/Off	Open/On	Open/On
Sect 1 Defrost (Rly 3)	Off	On	On	Off	Off	Off
Sect 2 Defrost (Rly 4)	Off	On	On	Off	Off	Off
Fan Rly (On in def) (Rly 5)	On	On	On	On	Off	On
Fan Rly (Off in def) (Rly 5)	Off	Off	Off	Off	Off	On

Defrost Termination

Defrost termination will be when the temperature parameter "def terminate" has been reached on the "defrost termination" probe for a given section. If the "defrost termination" probe is not fitted, defrost termination will occur when: -

The "Air Off" probe for that section reaches the set point

Or if the "Air Off" probe is not faulty termination will occur when the time-out period has elapsed.

Fan Delay after Defrost

The fans will come back on when: -

The fan delay time has elapsed if the "fan delay mode" is set to time

Or

If the fan delay mode is set to "temp", the fans will come on when the defrost termination probe for that section reaches the fan delay set point, or on the time parameter, whichever occurs first.

If the "defrost termination" probe is not fitted, the fans will come on when: -

The "air off" probe for that section reaches the control set point

Defrosts per sections are started at the same time, defrost termination (switching off the defrost control relay) is independent, but drain down and subsequent defrost states are performed simultaneously when the last section terminates.



Ensure that all power is switched off before installing or maintaining this product

Network Configuration

The final section to setup is the network address. In all instances, this must be done before the controller is plugged into the site network. The controllers have an auto-initialise function, which will automatically log the device onto the site network. If the wrong address has been entered onto the network, you will have to reset the controller address by setting the address to 00-0, and then re-enter the correct address. (You may have to deregister the wrong address from the home system as well).

When logging a Mercury or Intuitive Mercury with an RS232 interface onto a network you must first connect the controller to a communications module, this is either a 485 Legacy, RDM Wireless Mesh system, IP Futura or Mercury Switch. When using an Intuitive Mercury controller, the controller has to have the correct network card fitted (see "compatible network interfaces"). For connection to a Mercury Switch (Hub) or an external network interface, the standard fitment RS232 network card is utilized.

RS485 Legacy module / Intuitive Internal RS485 Network card

Connecting an RS485 legacy Module or an Intuitive Internal RS485 network card to the controller will govern which set up screens are made available. Both modules support the "Genus" protocol only.

Display	Option
485t	485 Network Type
485A	485 Address/Name
gAdd	Show underlying network address assigned to controller
rLog	Re-log the controller back onto the network
CLrA	Clear the address/name from the controller
ESC	Exit network menu. N.B. this option must be selected to save any changes made in this menu

The 485t option shows a value representing the network type. The possible values are:

Value	Network Type
1	Genus compatible (all versions)
2	RDM Wireless Mesh System (Wireless Mesh)

The 485A option shows a value representing either the name of the controller in a Genus compatible or Wireless Mesh network.

Wireless Mesh Communication Module

RDM Wireless Mesh System, please refer to the RDM Wireless Mesh Communication Module user guide, which can be obtained from the RDM website, for information regarding connecting a controller to a Wireless Mesh network.

The value shown in 485A is of the form 05-6. This means the controller would try to log onto a Genus compatible or RDM Wireless Mesh network using the name 'RC05-6'.

The gAdd option displays (in hexadecimal format) the underlying network address assigned to the controller when it was logged onto the network.

The rLog option allows the controller to be logged back onto the network with its current name. The 'rLog' message will flash for confirmation. Press the Enter button to execute the command, Up or Down buttons to cancel.

Fast Network Address Reset

The CLrA option will clear out the network address and name in the controller. The 'CLrA' message will flash for confirmation. Press the Enter button to execute the command, Up or Down buttons to cancel.

To enter this mode, hold the Enter, Up and Down buttons together for approximately 3 seconds until the message CLrA appears on the display. CLrA is the first option in the menu consisting of the following options:

Display	Option
CLrA	Clear the address/name from the controller
ESC	Exit Setup mode

Pressing the Enter button to select the CLrA option will cause the 'CLrA' message to flash for confirmation, if the network type is set to Genus compatible. Press the Enter button to execute the command, Up or Down buttons to cancel. If the network type is not set to Genus compatible then the CLrA message will not flash and the ESC option can be used to exit the menu.

IP Futura module / Intuitive Internal IP Network card

In an IP system there are two options,

- IP-L
- IP-r

IP-L allows you to fix an IP address into the controller, which you would use when you are connecting the controllers onto a customer's local area network. This would allow the customer to view each controller using Internet Explorer

IP-r allows you to give each controller on the system a unique number. This number is then allocated a dynamic IP address by the system DHCP server (such as the RDM Data Manager or Data Director)



Ensure that all power is switched off before installing or maintaining this product

IP-L

To configure the communication module or network card for IP-L, set all three rotary switches to zero. The module should then be connected to the controller. In the case of an Intuitive Mercury controller where the network card is already fitted, the controller should be powered off, all three rotary switches set to zero and the controller powered on.

1. nEt. From the function menu you can now select nEt
 - Press enter and the display will show "IP-L", press enter
 - You can now set the address using the table below

Display	Option
IP-1	IP Address byte 1
IP-2	IP Address byte 2
IP-3	IP Address byte 3
IP-4	IP Address byte 4
nL	Network Mask Length
gt-1	Gateway Address byte 1
gt-2	Gateway Address byte 2
gt-3	Gateway Address byte 3
gt-4	Gateway Address byte 4
ESC	Exit network menu. N.B. this option must be selected to save any changes made in this menu

IP-r

To configure the communication module for IP-r, set the three rotary switches to give each controller a unique identifier. The module should then be connected to the controller and the network. In the case of an Intuitive Mercury controller where the network card is already fitted, the three rotary switches must be set when the controller is powered off, the controller should then be powered on to connect to the network.

2. nEt. From the function menu you can now select nEt
 - Press enter and the display will show "IP-r", press enter
 - You can now view only the address given by the DHCP server

To ease setup, a single network mask length value is used. If the address has been specified with a network mask value in dotted IP format e.g. 255.255.255.0 then the table below gives the conversion:

Mask	Length	Mask	Length	Mask	Length
		255.255.254.0	23	255.254.0.0	15
255.255.255.252	30	255.255.252.0	22	255.252.0.0	14
255.255.255.248	29	255.255.248.0	21	255.248.0.0	13
255.255.255.240	28	255.255.240.0	20	255.240.0.0	12
255.255.255.224	27	255.255.224.0	19	255.224.0.0	11
255.255.255.192	26	255.255.192.0	18	255.192.0.0	10
255.255.255.128	25	255.255.128.0	17	255.128.0.0	09
255.255.255.0	24	255.255.0.0	16	255.0.0.0	08

Mercury Switch

Please refer to the Mercury Switch user guide, which can be obtained from the RDM website, for information regarding connecting a controller to a network.

Viewing

Apart from setting up the controller, you can also view the status of the inputs and outputs and controller states.

From the function menu, select "I/O", press enter. You can now scroll through the IO table as set out below. Inputs and outputs that do not apply to a particular controller type will be greyed out.



Ensure that all power is switched off before installing or maintaining this product

Input / Output Table

Number	IO	Range* °C (°F)	Step	Units	Types 1&2	Types 3&4	Types 5&6
I-10	Plant Fault 1	0 (OK), 1 (Alarm)			✓	✓	✓
I-11	Case Clean	0 (Off), 1 (On)			✓	✓	✓
I-12	Door Sensor	0 (Closed), 1 (Open)					✓
I-13	Person Trapped	0 (OK), 1 (Alarm)					✓
I-14	Plant Fault 2	0 (OK), 1 (Alarm)			✓		
I-17	MOP	0 (Off), 1 (On)				✓	✓
I-30	Section 1 Control Temp.	-49 to 60 (-56.2 to 140)	0.1	°C (°F)	✓	✓	✓
I-31	Section 1 Display temp	-49 to 60 (-56.2 to 140)	0.1	°C (°F)	✓	✓	✓
I-32	Section 1 Air on Probe	-49 to 60 (-56.2 to 140)	0.1	°C (°F)	✓	✓	✓
I-33	Section 1 Air off Probe	-49 to 60 (-56.2 to 140)	0.1	°C (°F)	✓	✓	✓
I-34	Section 1 Defrost Probe	-49 to 60 (-56.2 to 140)	0.1	°C (°F)	✓	✓	✓
I-35	Section 2 Control Temp.	-49 to 60 (-56.2 to 140)	0.1	°C (°F)	✓	✓	✓
I-36	Section 2 Display temp	-49 to 60 (-56.2 to 140)	0.1	°C (°F)	✓	✓	✓
I-37	Section 2 Air on Probe	-49 to 60 (-56.2 to 140)	0.1	°C (°F)	✓	✓	✓
I-38	Section 2 Air off Probe	-49 to 60 (-56.2 to 140)	0.1	°C (°F)	✓	✓	✓
I-39	Section 2 Defrost Probe	-49 to 60 (-56.2 to 140)	0.1	°C (°F)	✓	✓	✓
O-03	Compressor A	0 (Off), 1 (On)			✓		
O-04	Compressor B	0 (Off), 1 (On)			✓		
O-07	Case Fans	00:00 to 23:59			✓	✓	✓
O-10	Last Defrost Time	00:00 to 23:59	00:01	hh:mm	✓	✓	✓
O-13	Last Defrost Type	0 (None), 1 (Internal), 2 (External) 3 (Network), 4 (Display), 5 (Timed) 6(Forced), 7(Skipped)			✓	✓	✓
O-18	Run Time	0 – 128	1	KHrs	✓	✓	✓
O-20	Door Open Time	00:00 to 23:59	00:01	hh:mm			✓
O-21	Door Open Length	00:00 to 03:00	00:01	hh:mm			✓
O-31	Section 1 Defrost Control	0 (Off), 1 (On)			✓	✓	✓
O-32	Section 2 Defrost Control	0 (Off), 1 (On)			✓	✓	✓
O-33	Last Section 1 Defrost Length	00:00 to 03:00	00:01	hh:mm	✓	✓	✓
O-34	Last Section 2 Defrost Length	00:00 to 03:00	00:01	hh:mm	✓	✓	✓
O-35	Last Section 1 Defrost Temp	-49 to 60 (-56.2 to 140)	0.1	Deg	✓	✓	✓
O-36	Last Section 2 Defrost Temp	-49 to 60 (-56.2 to 140)	0.1	Deg	✓	✓	✓
O-37	Setpoint 1 Offset	00:00 to 03:00	0.1	Deg	✓	✓	✓
O-38	Setpoint 2 Offset	-42 to 60 (-43.6 to 140)	0.1	Deg	✓	✓	✓
O-41	Section 1 LLV	0 (Closed), 1 (Open)				✓	✓
O-42	Section 2 LLV	0 (Closed), 1 (Open)				✓	✓
S-01	Control State	0 (Stabilise), 1 (Normal), 2 (Defrost Min), 3 (Defrost Max), 4 (Drain Down), 5 (Fan Delay), 6 (Recovery), 7 (OT Alarm), 8 (UT Alarm), 9 (Fans Only), 10 (Case Off), 11 (Pump Down), 12 (Defrost Hold)	1		✓	✓	✓
S-02							

Display Messages

The following alarms and messages can appear on the Mercury or Intuitive display.

Display Message	System status
Prb1 Ft	Section 1/2 Probe 1 Fault
Prb2 Ft	Section 1/2 Probe 2 Fault
rEC	Control State in Recovery
dEF	Control Sate in Defrost
FAn ONLY	Controller in Fans Only
CASE OFF	Controller in Case Off
Ot AL	Over Temperature Alarm
Ut AL	Under Temperature Alarm
TrAP	Person Trapped Alarm
Plt	Plant Fault



Ensure that all power is switched off before installing or maintaining this product

Network Alarms

The table below shows the text and associated type number that is sent to the system "front end". The type number is normally used to provide different alarm actions.

Alarm text	Type # (index)
Missed defrost	15
Plant Fault 1	3
Section 1 over temperature	4
Section 2 over temperature	4
Section 1 under temperature	5
Section 2 under temperature	5
Section 1 Probe 1 Faulty	6

Alarm text	Type # (index)
Section 1 Probe 2 Faulty	6
Section 2 Probe 1 Faulty	6
Section 2 Probe 2 Faulty	6
Door Left Open	2
Person Trapped	1
Plant Fault 2	3
Case Clean	29

Modifying controller states

During normal operation you can change the following states from the function menu

Fans Only "FAnS"

Selecting the Fans Only option will put the controller into the Fans Only state if the current state is not Fans Only. If the current state is Fans Only then the controller will change to the Normal state. Selecting this option will exit the setup menu automatically. The display will show "FAnS OnLy"

If a remote display with key switch is being used, this function can be invoked by turning the key switch to the fans only position (90 degrees clockwise) with parameter P85 set to "fans"

Case Off "CASE"

Selecting the Case Off option will put the controller into the Case Off state if the current state is not Case Off. If the current state is Case Off then the controller will change to the Normal state. Selecting this option will exit the setup menu automatically. The display will show "CASE OFF". An alarm is generated, fixed delay of 1 minute, when the controller is placed into the Case Off state.

If a remote display with key switch is being used, this function can be invoked by turning the key switch to the case-off position. (Clockwise 90 degrees) with parameter P85 set to "case".

Lights Only "LitS"

Selecting the Lights Only option will put the controller into the Lights Only state if the current state is not Lights Only. If the current state is Lights Only then the controller will change to the Normal state. Selecting this option will exit the setup menu automatically. The display will show "LitS OnLy"

Note. When lights are being used in "Remote" mode with a timing channel: -

If the controller goes offline, the lights are turned ON after a delay of 5 minutes. The lights will stay on until the controller comes back on-line where they will revert to the state of the timing channel being used.

Probe Offset

This feature allows each probe value to be modified by an "offset". Offset values are from -10°C (-18°F) to +10°C (+18°F) and on a channel basis. Example C1 = Probe 1.

Operation

This controller has two independent thermostat functions. Section 1 thermostat is controlled by the weighted average of Section 1 Air-On and Air Off probes, whilst Section 2 thermostat is controlled by the weighted average of Section 2 Air-on and Air-Off probes. Each section has an associated defrost termination probe and separate defrost output control relays. A single fan relay is used for both sections.

Defrosts per sections are started at the same time, defrost termination (switching off the defrost control relay) is independent, but drain down and subsequent defrost states are performed simultaneously when the last section terminates.

The controller display does not differentiate section alarm messages.



Ensure that all power is switched off before installing or maintaining this product

Remote Commands

The following commands can be used by a Data Builder program: -

Command	Value to send	Description	Conditions
Defrost Command	1	Initiates a defrost cycle	Defrost mode: remote
Defrost Command	3	Terminates the defrost	Defrost mode: remote Defrost hold: On Defrost min state complete
Setpoint 1 Command	$\pm 18^{\circ}\text{C}$	Is added to or subtracted from the setpoint	
Setpoint 2 Command	$\pm 18^{\circ}\text{C}$	Is added to or subtracted from the setpoint	
Case Off Command	5	Sets the controller to Case Off	
	0	Restores the controller from Case Off to Normal	
Haccp Command	0	HACCP LED OFF	
	1	HACCP LED On	
	2	HACCP LED Flashes	
Button Command	0	Buttons backlights Off	
	1	Buttons backlights On	
	2	Buttons Backlights Flash	
Valve Command	2	Shuts the valves off	
	1	Restores the valves to normal operation	

Use an "Analogue Out" block configured to the controller name and in the value field type in the command you require. Use a "Setting block" as the input to the "Analogue Out" block to send the Value.

See Example on the right, which switches on the Haccp LED on CROOM1

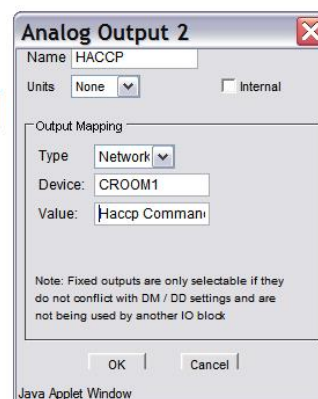
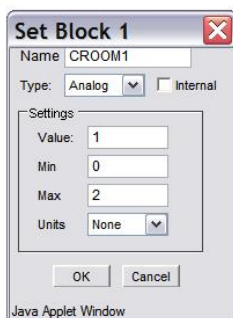

Ensure that all power is switched off before installing or maintaining this product

Specification

	Mercury Mk2 Controller PR0710-TWO	Intuitive Mercury controller PR0750-TWO
Power requirements		
Supply Voltage Range	100 - 240 Vac ±10%	100 - 240 Vac ±10%
Supply Frequency	50 - 60 Hz	50 - 60 Hz
Maximum supply current	5.2 Amps (when relay 5 is fully loaded)	2 Amps
Typical supply current	<1 Amp	<1 Amp
General		
Operating temperature range	+5°C to +50°C	-10°C to +60°C
Storage temperature range	-20°C to +65°C	-20°C to +65°C
Environmental	Indoor use at altitudes up to 2000m, pollution degree 1, installation category II. Voltage fluctuations not to exceed ±10% of nominal voltage.	Indoor use at altitudes up to 2000m, pollution degree 1, installation category II. Voltage fluctuations not to exceed ±10% of nominal voltage.
Size	78mm (W) x 36mm (H) x 110mm (D)	157mm (W) x 67mm (H) x 120 (D)
Approx Weight	170 grams	500 grams
Safety	EN61010	EN61010
EMC	EN61326; 1997 +Amdt. A1; 1998	EN61326; 1997 +Amdt. A1; 1998
Ventilation	There is no requirement for forced cooling ventilation	There is no requirement for forced cooling ventilation
Class 2 Insulation	No protective Earth is required and none should be fitted	No protective Earth is required and none should be fitted
Supply Fuse	The host equipment must provide a suitable external over-current protection device such as: - Fuse: 6.3A 240 Vac Antisurge (T) HRC conforming to IEC 60127	Built in fuse holder, fuse 2A 240Vac Antisurge (T) HRC conforming to IEC60127, 32 x 6.3mm
Or MCB	6A, 240 VAC Type C conforming to BS EN 60898	2A, 240 VAC Type C conforming to BS EN 60898 (Note: controller has integral 2A fuse)
Relay Fuse	Not Fitted	10A 240Vac Antisurge (T) HRC conforming to IEC60127, 32 x 6.3mm
Relay Specification		
Relays 1-4 Mechanical Type (M) Exclusive common		
Max current	6A Resistive (CosØ = 1) 2A Inductive (CosØ = 04)	.10A Resistive (CosØ = 1) 3A Inductive (CosØ = 04)
Max voltage	250Vac, 30V dc	250Vac, 30V dc
Relay Fuse	N/A	10A 240Vac Antisurge (T) HRC conforming to IEC60127, 32 x 6.3mm
Relay 1 Solid State Type (E) Exclusive common		
Max current	1.5A	1.5A
Max voltage	280Vac	280Vac
Relay 5 Mechanical Type (M) Common connected to supply live		Relay 5 Mechanical Type (M) Exclusive common
Max current	3A (non inductive), COSφ=0.4 2A (inductive load) 200,000 operations	10A Resistive (CosØ = 1) 3A Inductive (CosØ = 0.4)
Max voltage	250Vac (Internal supply)	250Vac, 30V dc (external supply)
	For compliance with the LVD, relays 3, 4 and 5 commons must be at the same potential as the supply voltage	All relays are independent and can operate at different potentials to the supply voltage.



Warning: Relay 5 output has hazardous voltages (Supply input voltage potential)
This does not apply to the Intuitive Mercury controller



Ensure that all power is switched off before installing or maintaining this product

Inputs

Input resistance: 3.01K Ohms (for PTC or NTC type probes)
 Input type: PT1000 or NTC2K or NTC2K25 or NTC10K (selectable)

Comms: RS232 with flow control

Switched Resistor Example Wiring

Example of resistor fitted on a probe input. Connect to remote switch or relay

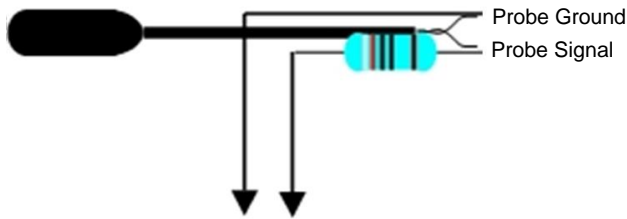

Installation

Panel Cut-out and Clearances

Mercury Mk2 (Flush mount controller)

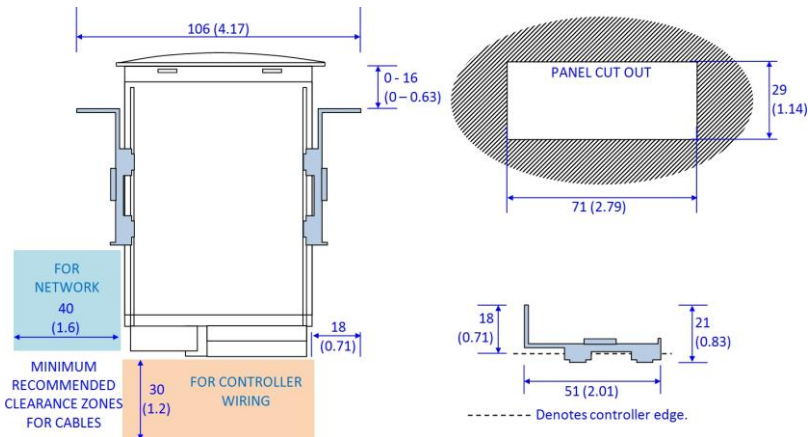

Fixing

The controller is fixed by sliding the 2 plastic retaining clips up to rear of the panel. These clips have a ratchet action and can be removed by holding in the clip sides and sliding back.

There is no requirement for forced cooling ventilation

Dimensions

Mercury Mk2

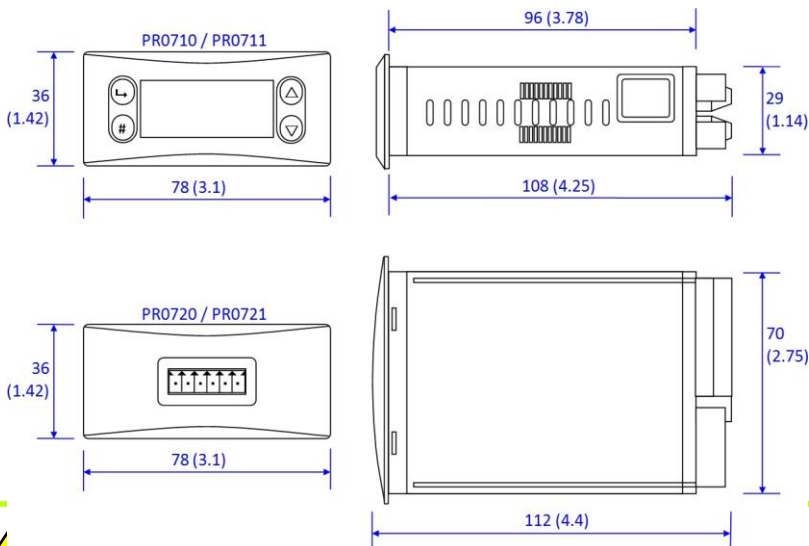

Switched on before installing or maintaining this product

Dimensions

Intuitive Mercury controller

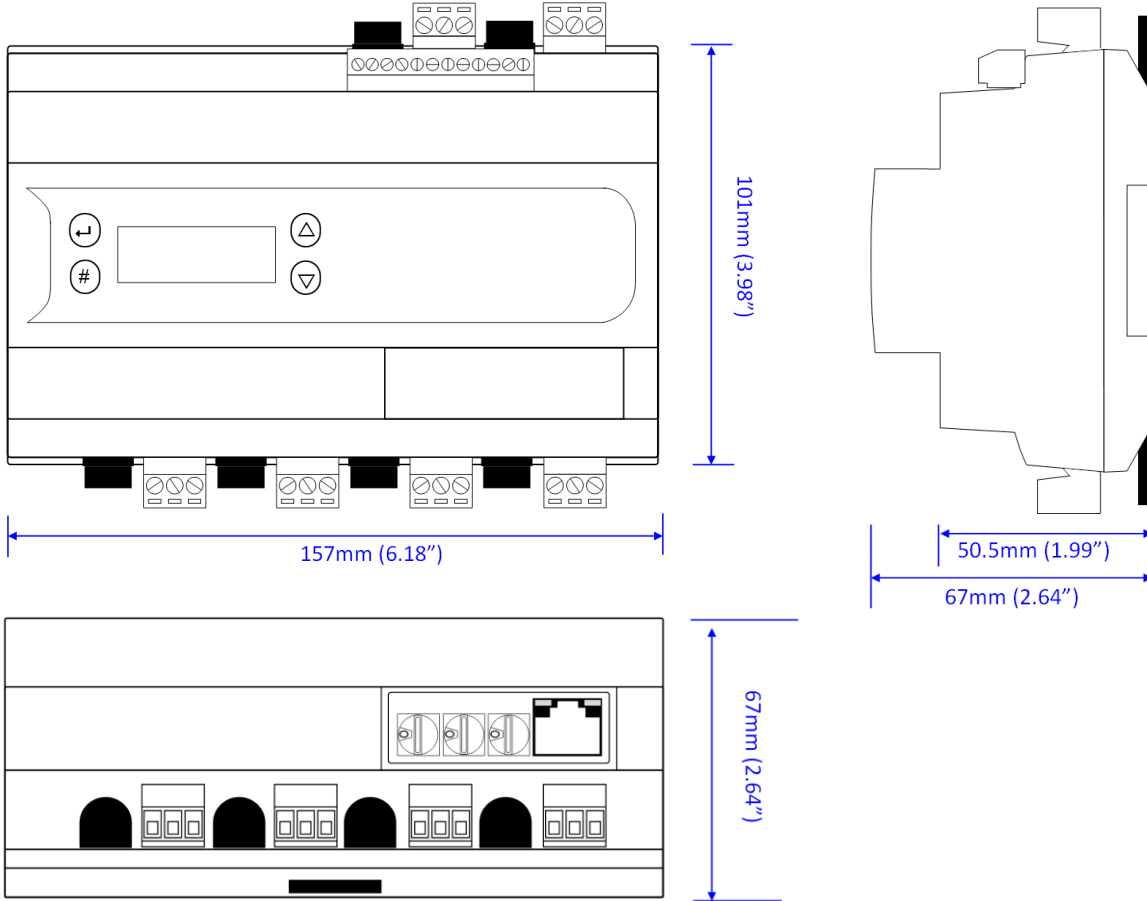

Intuitive Mercury Mounting Instructions

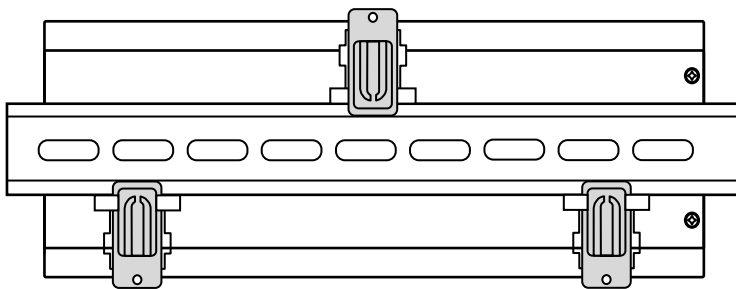

Three clips fix the Intuitive Mercury securely to DIN rail. Pull each clip until it “clicks” to remove the controller. Each clip has a mounting hole to provide an alternative fixing mechanism to DIN mounting.

Cleaning

Do not wet the controller when cleaning. Clean the front by wiping with slightly dampened lint free cloth.



Ensure that all power is switched off before installing or maintaining this product

Disclaimer

The specifications of the product detailed in this document may change without notice. RDM Ltd shall not be liable for errors or omissions, for incidental or consequential damages, directly or indirectly, in connection with the furnishing, performance or misuse of this product or document.

Appendix 1 Resistor Part Numbers

820R Resistor Part numbers

Farnell: 946-3852 or 934-3563	RS Components	157-452 or 148-483
----------------------------------	---------------	-----------------------

590R Resistor Part numbers

Farnell: 946-9150 or 950-2424 or 108-3226	RS Components	487-5836 or 165-545
---	---------------	------------------------

2K7 Resistor Part numbers

Farnell: 934-2940 or 934-1641	RS Components	151-072 or 683-2812
----------------------------------	---------------	------------------------



Ensure that all power is switched off before installing or maintaining this product

Appendix 1 Defrost Cycles

Fans On in Defrost

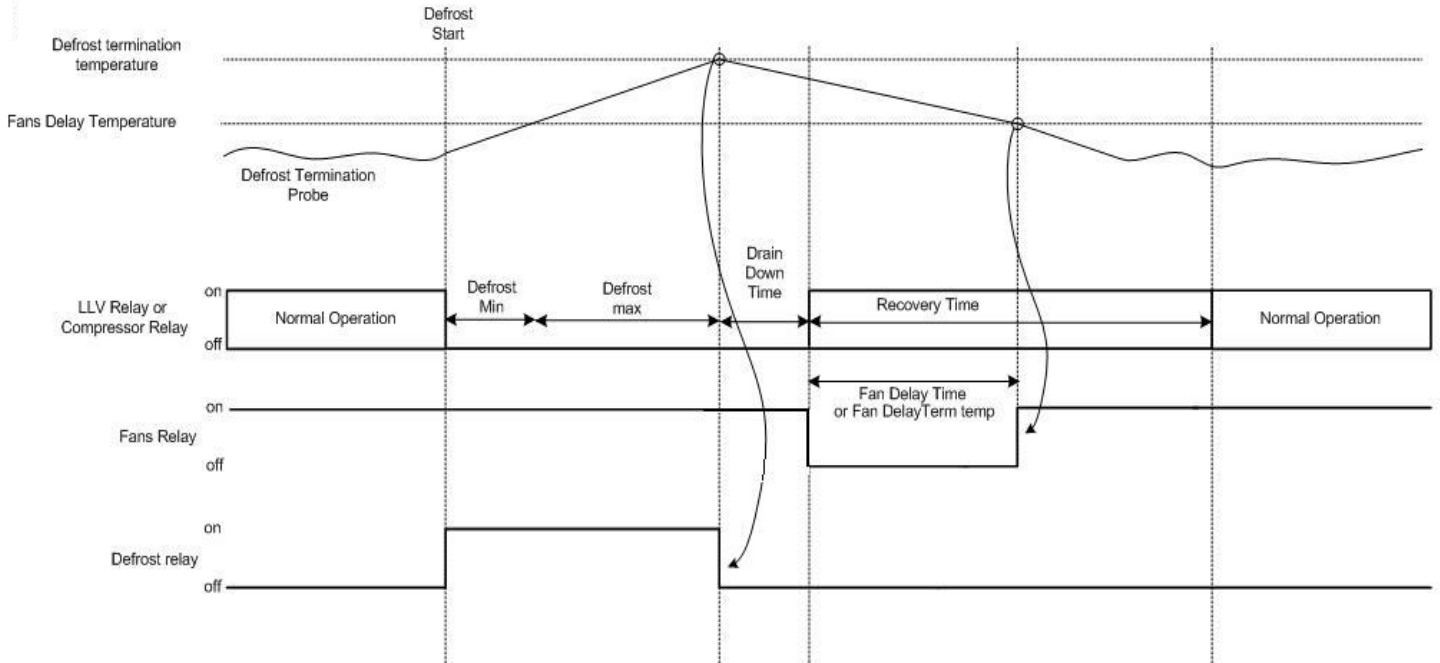

Fans Off in Defrost

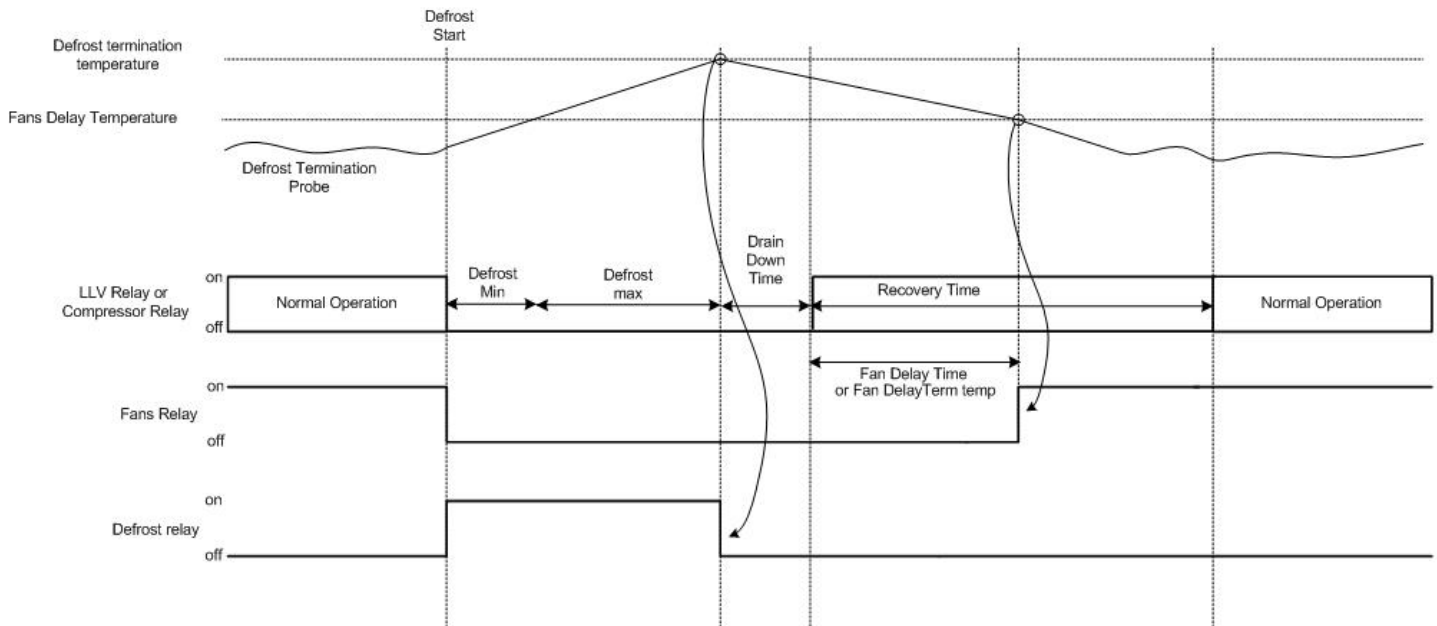

Revision History

Revision	Date	Changes
1.0	03/05/2011	Introduction of Intuitive range
1.0b	05/01/2015	Operating Temperature range updated.



Ensure that all power is switched off before installing or maintaining this product