

Resource  
Data Management

# Intuitive Controller Expansion Boards

## Commissioning/User Guide

### Revision 1.3b

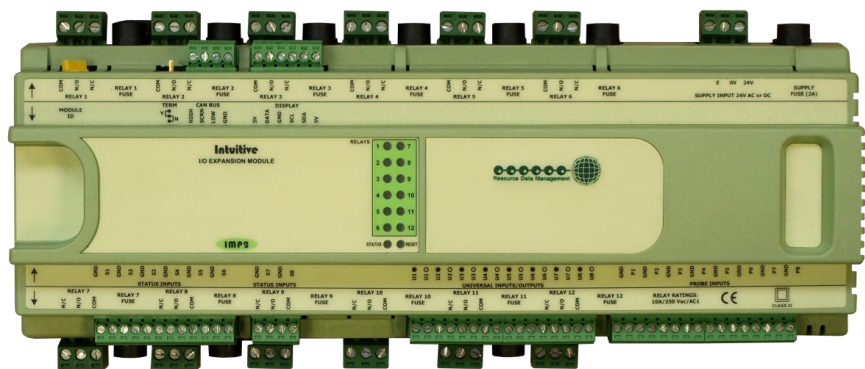

PR066X

## Contents

Intuitive Expansion Boards .....	3
Description .....	3
Configuration .....	3
Networks .....	3
Connecting to the controller .....	3
Expansion Board Wiring Connections .....	4
PR0660 Intuitive Stepper Expansion Board Wiring Connections .....	4
PR0661 Intuitive IO Expansion Board Wiring Connections .....	5
PR0662 Intuitive 48 Input Expansion Board Wiring Connections .....	6
PR0663 Mini Intuitive IO Expansion Module Wiring Connections .....	7
PR0663 4-4 Mini Intuitive IO 4-4 Expansion Module Wiring Connections .....	8
PR0663 8P-4E Mini Intuitive IO 8-4 Expansion Module Wiring Connections .....	9
PR0681 Mini Intuitive IO Expansion Module Wiring Connections .....	10
PR0653 Intuitive Stepper Module with Auto Close Wiring Connections .....	11
Intuitive Expansion Boards Universal Input / Output Connections .....	11
Technical Specifications .....	12
Stepper Expansion Board (PR0660) .....	12
I/O Expansion Board (PR0661) .....	13
48 Input Expansion Board (PR0662) .....	14
Mini IO Expansion Module (PR0663 / PR0663 4-4) .....	15
Mini IO Expansion Module (PR0681) .....	16
Installation .....	20
Mounting on to a DIN rail. ....	20



Please ensure all power is switched off before installing or maintaining this product.

# Intuitive Expansion Boards

## Description

The Intuitive Expansion boards, detailed below, are intended for use with either the Intuitive/Mini Intuitive controller (PR0650/PR0680) or the DMTouch/miniDM with a CANbus network interface. The expansion boards allow for additional inputs and outputs to expand upon the parent device's operation and functionality (such as TDB, Super Pack, CO2 or Circuit Control). A single Intuitive controller or DMTouch can have up to 10 expansion boards connected at any one time. The expansion boards have an in-built CANbus interface which allows for networking to the master device. All IO connectors are plug and socket and all within a small footprint which is panel or DIN rail mountable. A DIN mount, 24V 2A PSU (PR0625) is available for use with the expansion boards.

Intuitive Expansion Board Descriptions	Part Number
Intuitive Stepper with 8 Probe Inputs, 8 Status Inputs, 8 Universal I/O, 4 Relay Outputs and 6 Stepper Motor outputs.	PR0660
Intuitive IO Expansion Board with 8 Probe Inputs, 8 Status Inputs, 8 Universal I/Os and 12 Relay Outputs	PR0661
Intuitive 48 Probe Input Expansion Board with 8 Universal I/O and 48 Probe Inputs	PR0662
Mini Intuitive IO expansion module with 4 analogue inputs (mA/V) and 5 Relay Outputs	PR0663
Mini Intuitive IO expansion module with 4 Universal IO (mA/V) and 4 Relay Outputs	PR0663 4-4
Mini Intuitive IO expansion module with 4 Universal IO (mA/V), 5 Relay Outputs, 6 Probe Inputs, 4 Status Inputs and 2 PWM Outputs.	PR0681
Intuitive Stepper Module with Auto Close – 1 Stepper Motor Output, 1 Analogue Input (mA/V), 2 probe Inputs, 1 Digital Input & 1 Relay output	PR0653
Intuitive Stepper Module with Auto Close – 1 Stepper Motor Output, 1 Analogue Input (mA/V), 2 probe Inputs, 1 Digital Input & 1 Relay output. Valve closes on CANbus communication failure.	PR0653-C
Mini Intuitive IO Expansion Module with 8 Probe Inputs and 4 Solid State Relay (SSR) Outputs	PR0663 8P-4E
CANbus network cable (Per Meter)	PR0649

## Configuration

The expansion boards have no configuration until they have been configured in the master device to which they are connected. Please see the relevant documentation for their setup.

## Networks

The expansion boards have a built-in CANbus network interface that allows for connection to the Intuitive, DMTouch or another expansion board. For it to communicate successfully the Module ID rotary switch must be set to the desired address on each expansion board. Please refer to the Intuitive Controller user document (TDB for example) with regards to mapping the Expansion boards.

## Connecting to the controller

The master device (Intuitive or DMTouch) allows for the utilisation of an expansion board's inputs and outputs. The status of each input and output can be viewed from the main device's web pages. The expansion boards cannot be viewed directly.



Please ensure all power is switched off before installing or maintaining this product.

## Expansion Board Wiring Connections

### PR0660 Intuitive Stepper Expansion Board Wiring Connections

**PR0660**  
Bottom Row  
Connections

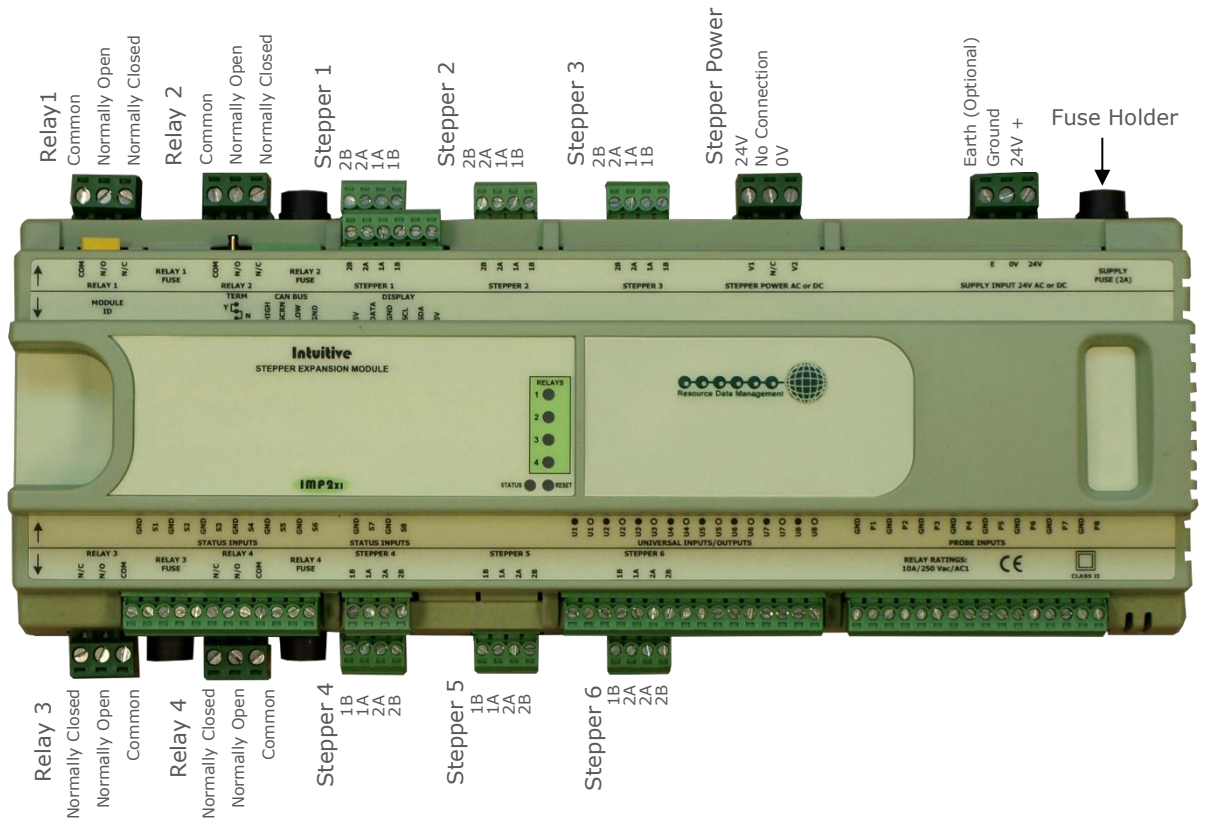

**PR0660**  
Top Row  
Connections

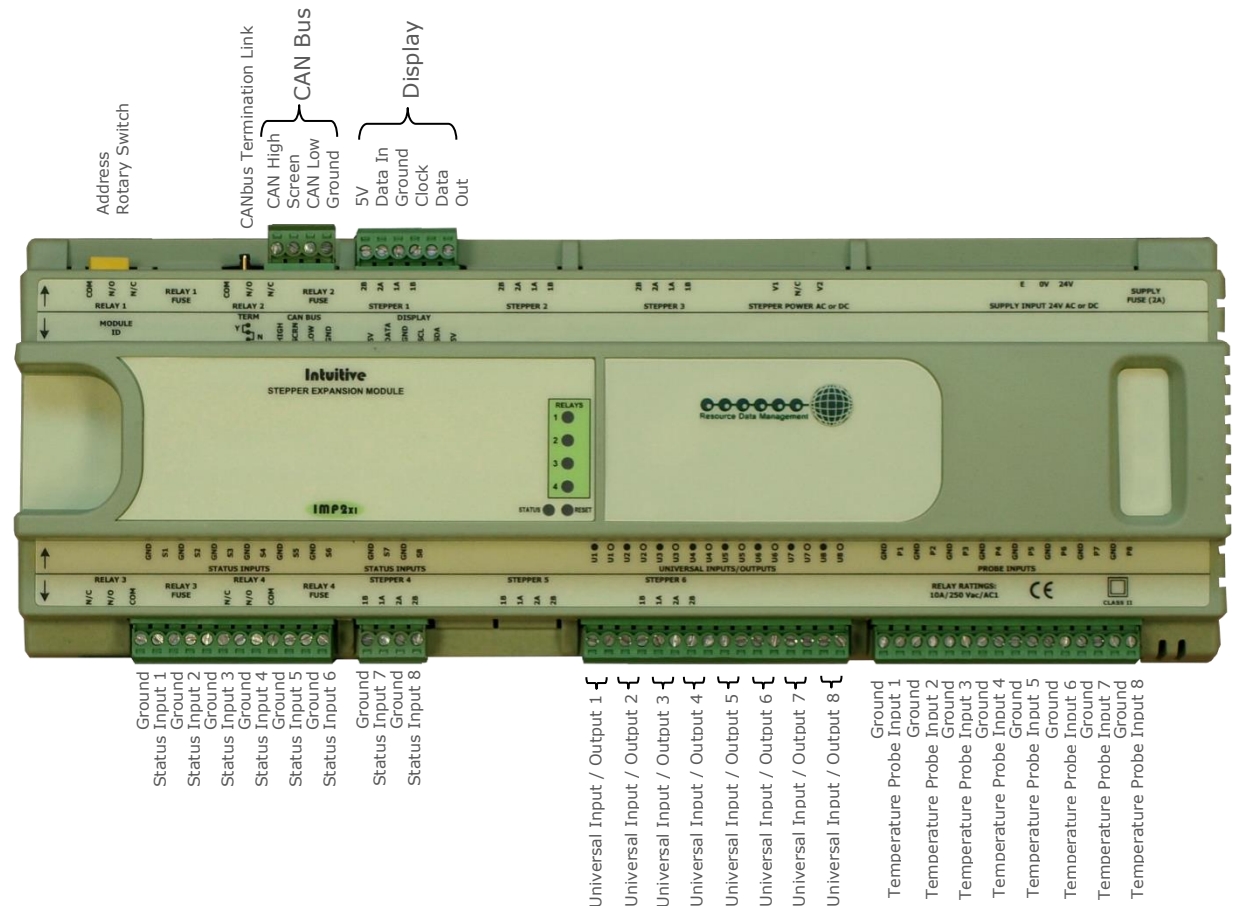

Please ensure all power is switched off before installing or maintaining this product.

## PR0661 Intuitive IO Expansion Board Wiring Connections

**PR0661**  
Bottom Row  
Connections

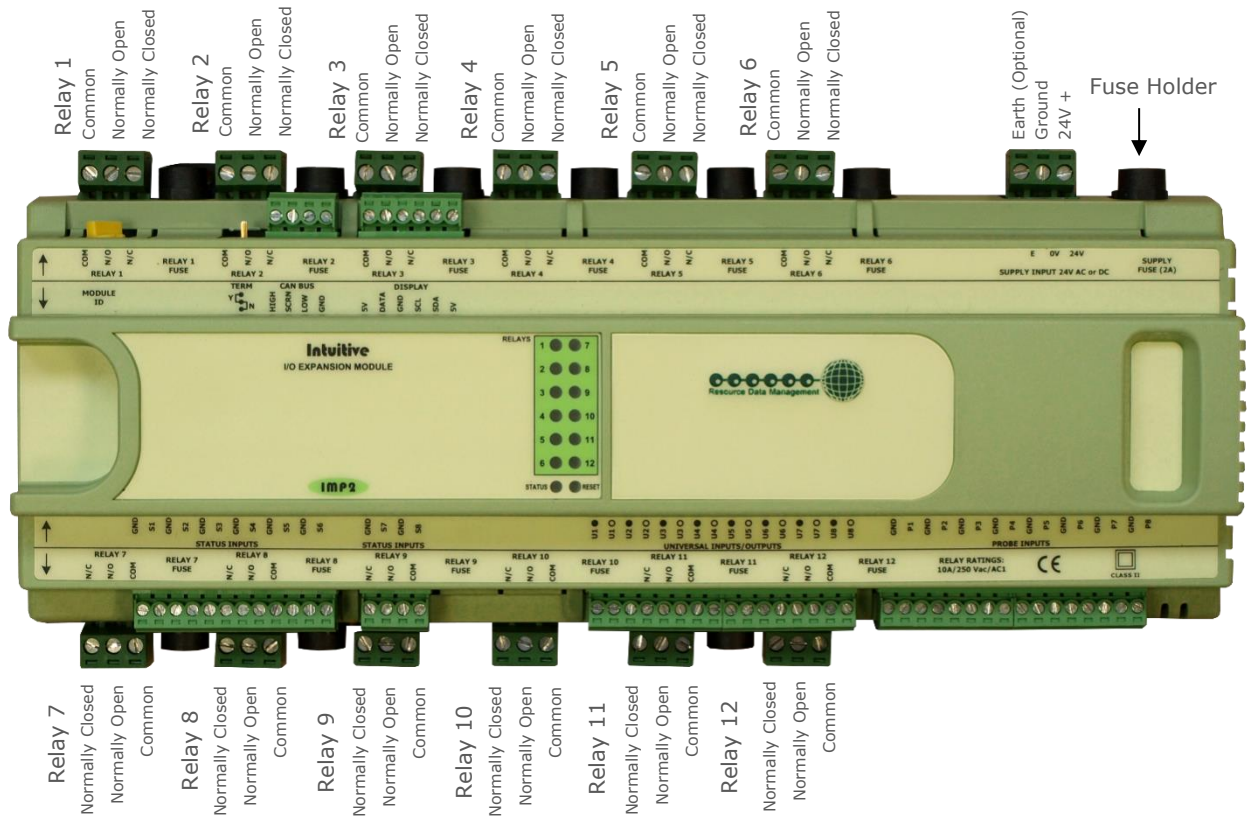

**PR0661**  
Top Row  
Connections

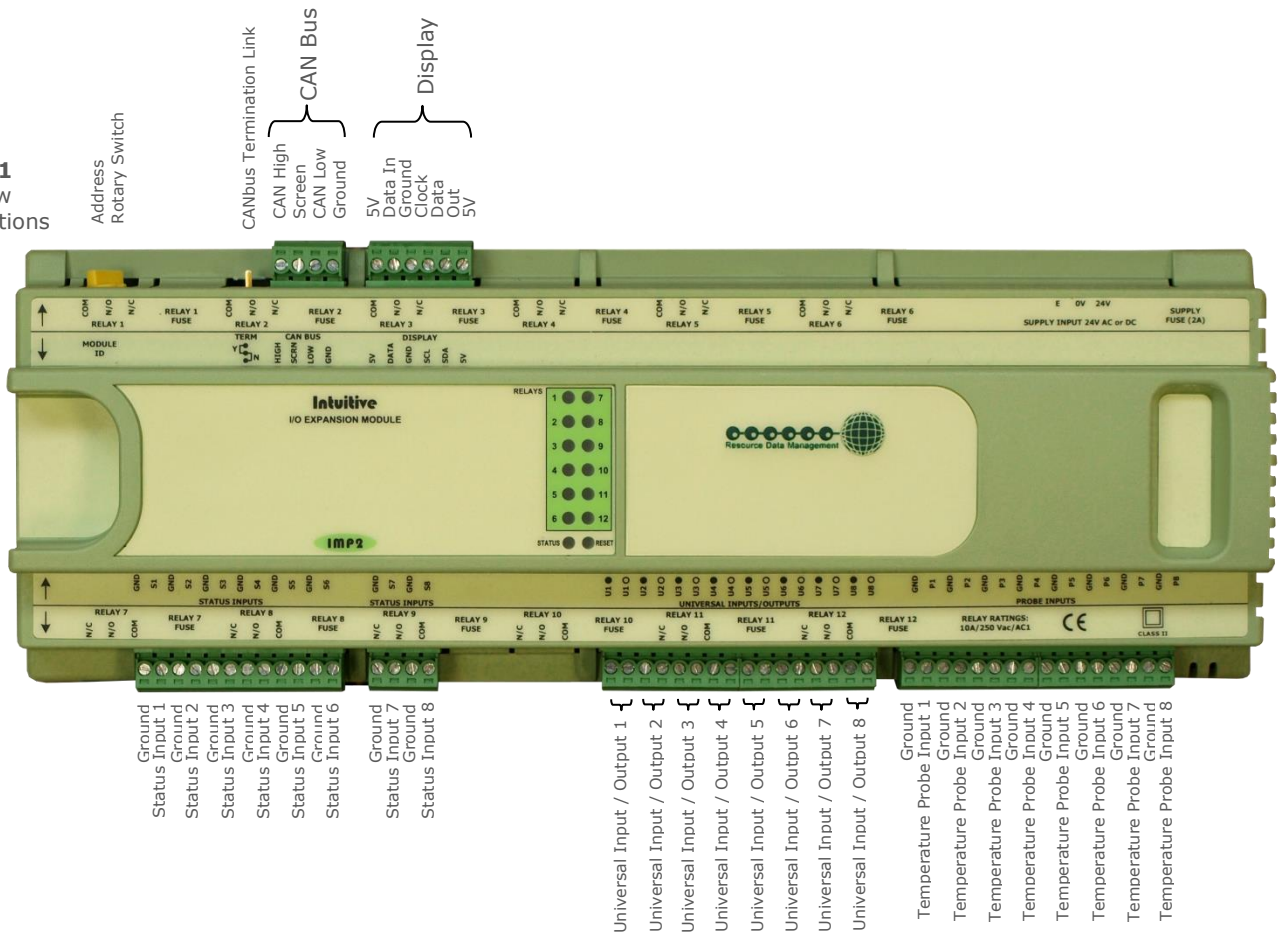

Please ensure all power is switched off before installing or maintaining this product.

## PR0662 Intuitive 48 Input Expansion Board Wiring Connections

### PR0662 Connections

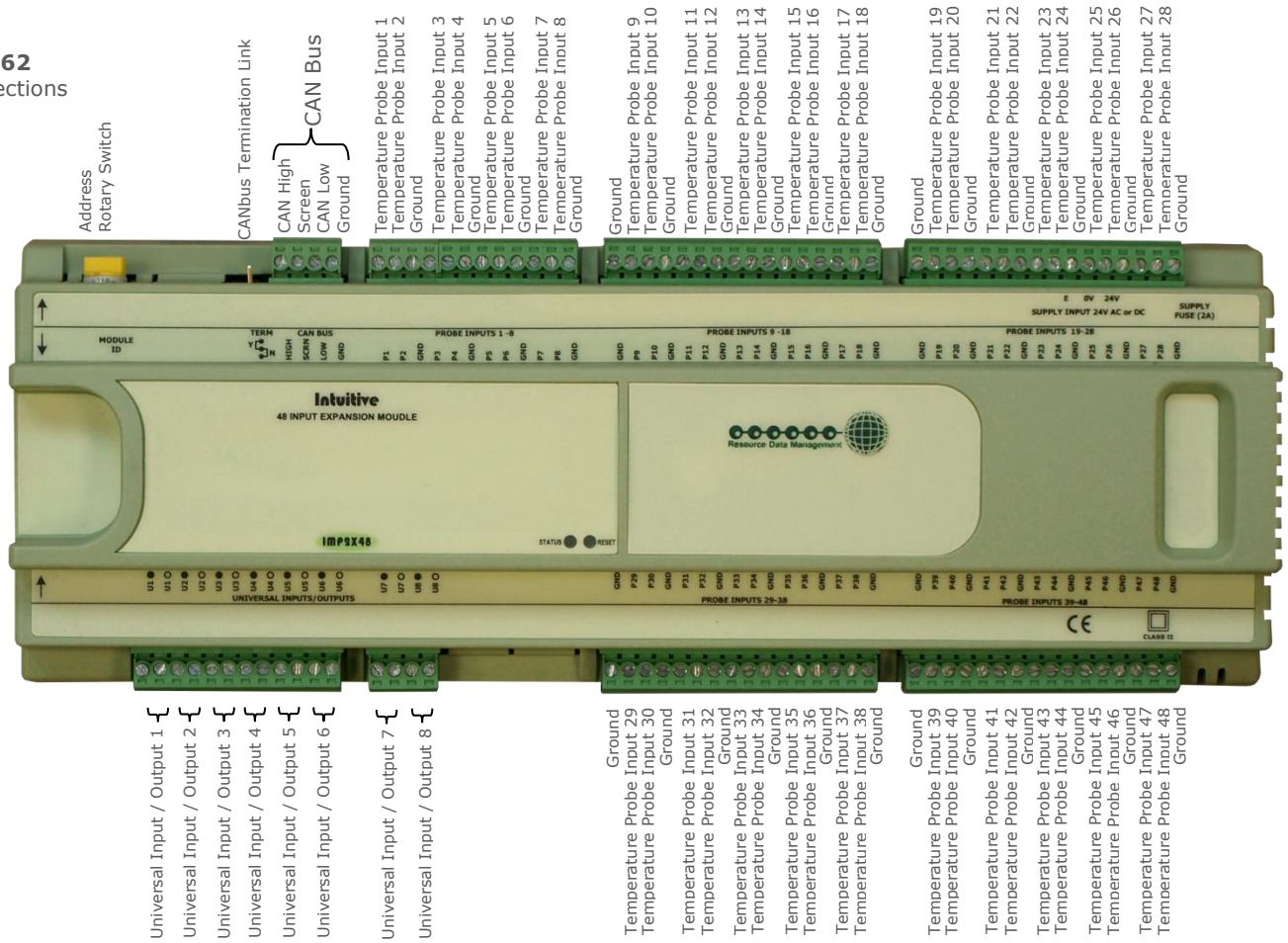

Please ensure all power is switched off before installing or maintaining this product.

## PR0663 Mini Intuitive IO Expansion Module Wiring Connections

**PR0663**  
Top Row  
Connections



**PR0663**  
Bottom Row  
Connections



Please ensure all power is switched off before installing or maintaining this product.

## PR0663 4-4 Mini Intuitive IO 4-4 Expansion Module Wiring Connections

**PR0663 4-4**  
Top Row  
Connections

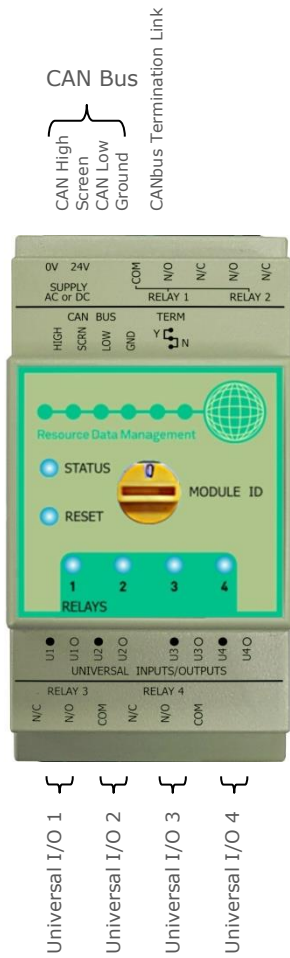

**PR0663 4-4**  
Bottom Row  
Connections

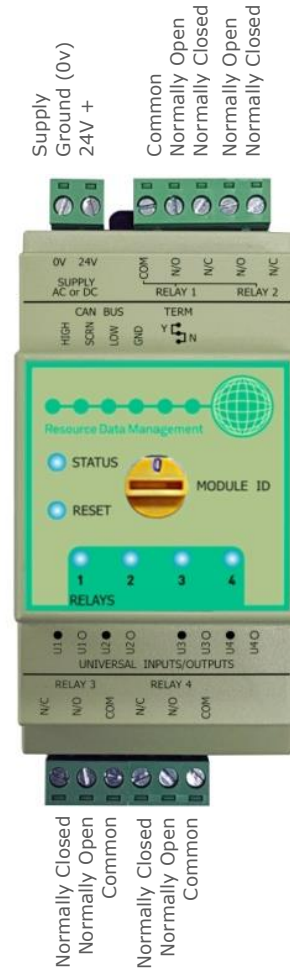

Please ensure all power is switched off before installing or maintaining this product.

## PR0663 8P-4E Mini Intuitive IO 8-4 Expansion Module Wiring Connections

**PR0663 8P-4E**  
Top Row  
Connections



**PR0663 8P-4E**  
Top Row  
Connections

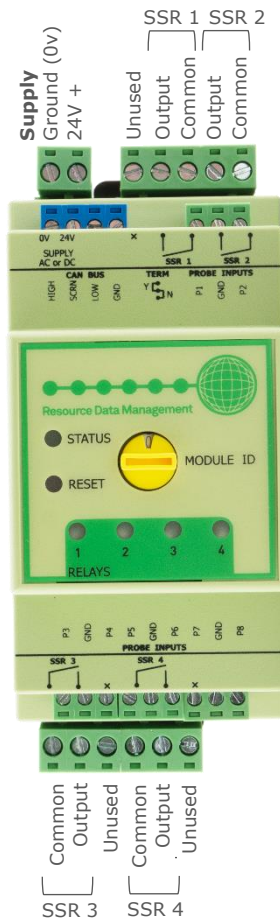

Please ensure all power is switched off before installing or maintaining this product.

## PR0681 Mini Intuitive IO Expansion Module Wiring Connections

**PR0681**  
Top Row  
Connections

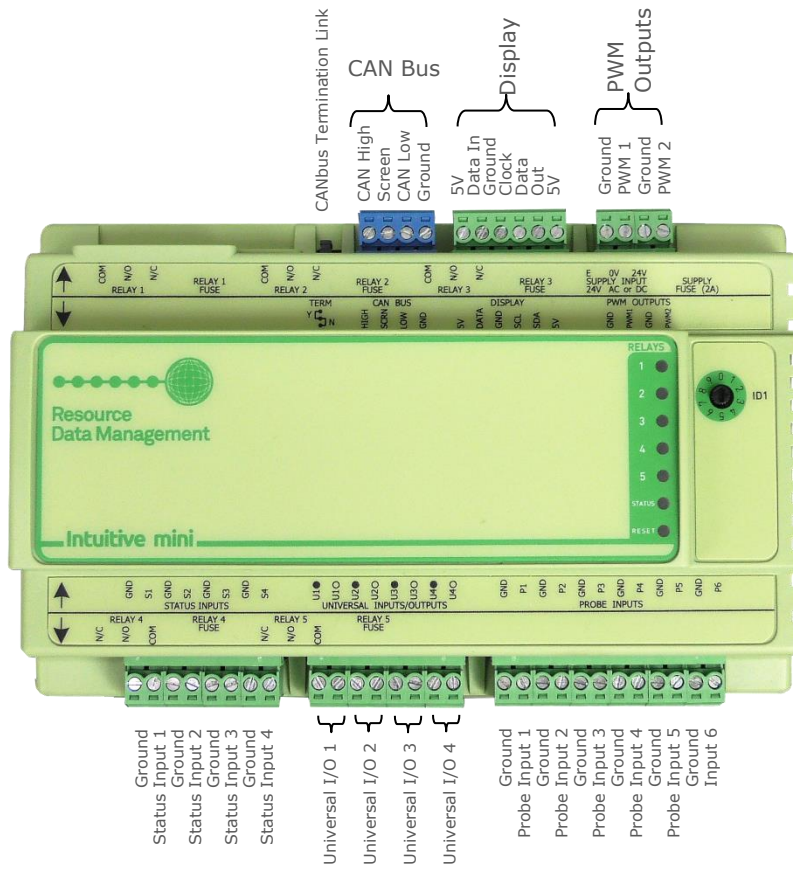

**PR0681**  
Top Bottom  
Connections

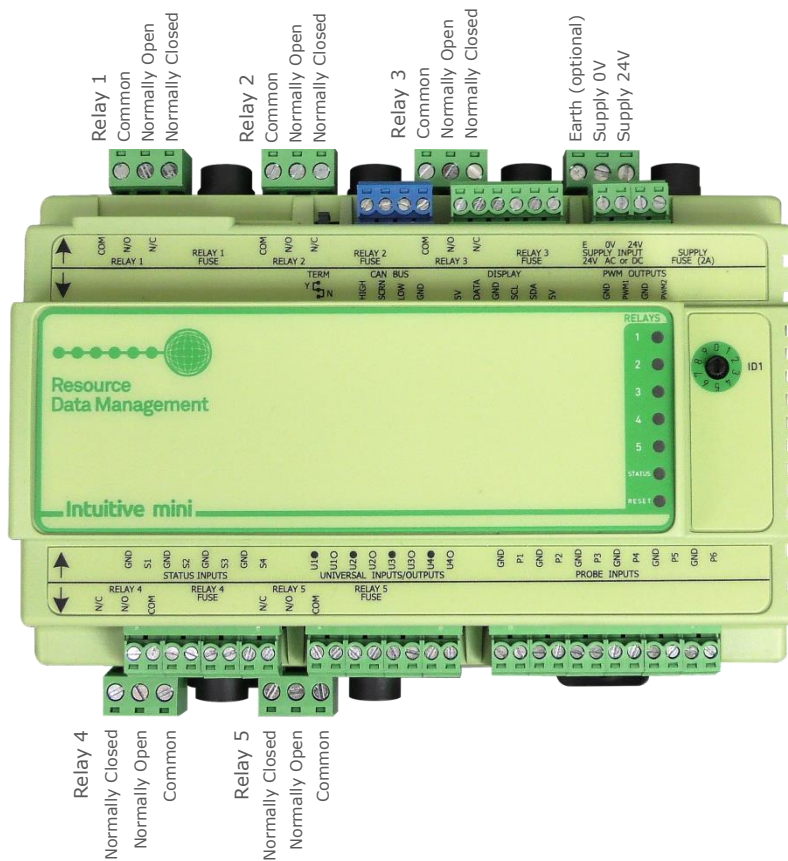

Please ensure all power is switched off before installing or maintaining this product.

## PR0653 Intuitive Stepper Module with Auto Close Wiring Connections

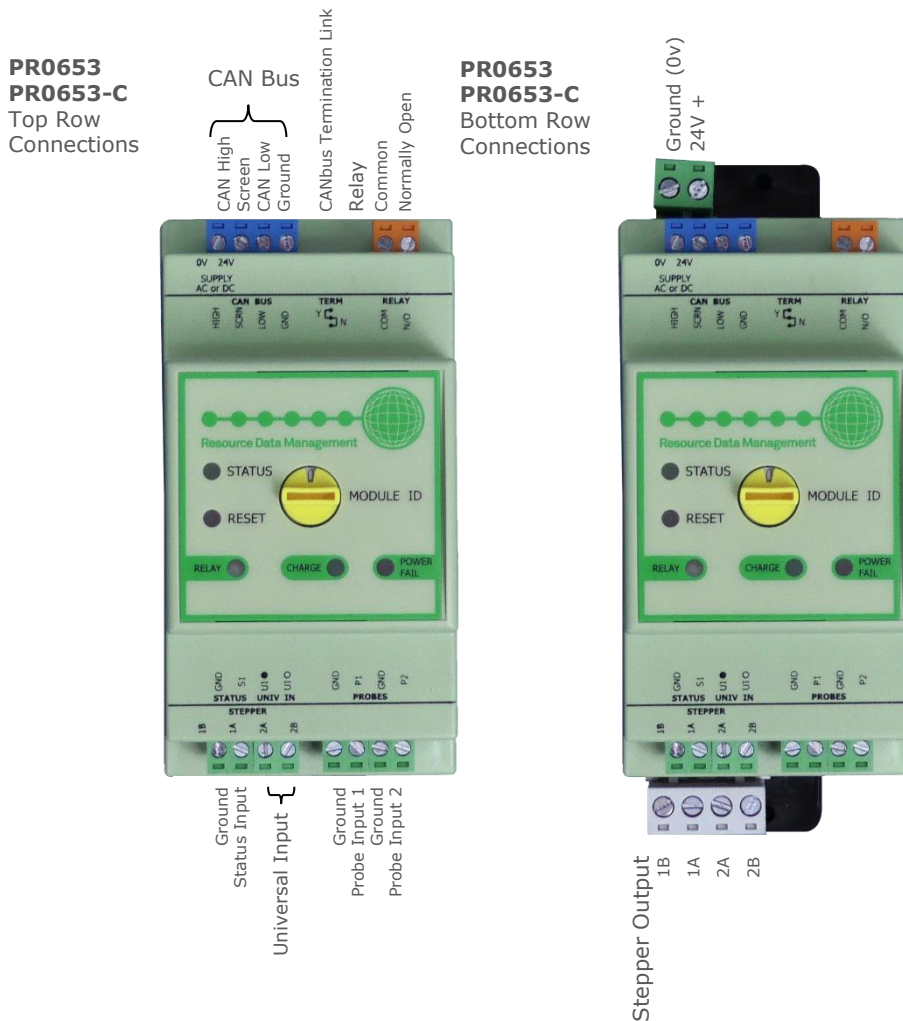

The module contains an internal back-up power supply based on Electric Double-Layer Capacitor (supercapacitor) technology that is used to close the valve when a power fail is detected. The module will run as configured in TDB until power to the module is interrupted - at which point the module internally detects this power failure and initiates an emergency closure of the valve. A list of valves that can be configured to utilise this feature is provided within the technical specification. In the event of CANbus communication being lost with the main controller, after 1 minute the PR0653 will set the valve position to the last hour average opening position while the PR0653-C will shut the valve fully until communications are re-established.

## Intuitive Expansion Boards Universal Input / Output Connections

Universal IO Type Configured	Terminal Markings
4-20mA Input	● Sig In    ○ 12Vdc Out
0-10V Input	● Ground    ○ Sig In
4-20mA Output	● Ground    ○ Sig Out
0-10V Output	● Ground    ○ Sig Out

**Note:** the PR0663 Mini IO expansion board and the PR0653 Stepper Module with Auto-Close only has Universal Analogue Inputs. They cannot be used as Analogue Outputs.



Please ensure all power is switched off before installing or maintaining this product.

## Technical Specifications

### Stepper Expansion Board (PR0660)

Power Requirements	
Supply Voltage Range	24VDC $\pm$ 10% or 24VAC $\pm$ 10%
Supply Frequency	DC or 50-60Hz $\pm$ 10%
Maximum Supply Current	1.5A (Not Including Stepper Power)
Typical Supply Current	<1A (Not Including Stepper Power)
General	
Operating Temperature Range	-40°C to +60°C (-40°F to +140°F)
Operating Humidity	80% Maximum
Storage Temperature Range	-40°C to +65°C (-40°F to +149°F)
Environmental	Indoor use at altitudes up to 2000m, pollution degree 2, installation category II.
Dimensions – L x W x H	280mm (11in) x 122mm (4.8in) x 67mm (2.6in)
Safety	EN 61010-1:2010
IP Rating	IP20
EMC	EN 61326-1:2013 FCC CFR 47 Parts 15.107 & 15.109 and ICES-003 Issue 6
Ventilation	There is no requirement for forced cooling ventilation
Class 2 Insulation	<b>No</b> protective Earth is required. A functional Earth may be fitted in noisy environments.
Supply Fuse	Built-In: 2A 240VAC Anti Surge (T) HRC conforming to IEC60127, 32x6.3mm
External MCB	2A 240VAC Type D conforming to BS EN 60898
Relays	
Max Current	10A Resistive Load ( $\cos \theta = 1$ )
Max Voltage	250VAC, 24VDC
Built-In Relay Fuse	10A 240Vac Anti Surge (T) HRC conforming to IEC60127, 32x6.3mm
Relay Spacing	Relays <b>1 &amp; 2</b> must together be either mains or low voltage. Relays <b>3 &amp; 4</b> independently allow the use of mains or low voltage on either relay.
PWM Outputs	
Frequency Range	0.016667Hz - 20kHz
Period Limits	Min: 50 $\mu$ s Max: 60s
Period Resolution	10 $\mu$ s
Duty Cycle Range	0 - 100%
Internal Pull-Up Enabled	High-Level Output Voltage: Typical 4.7V $\pm$ 200mV (recommended minimum 10k $\Omega$ load impedance)
Internal Pull-Up Disabled	External Voltage Range: 1V - 30V DC Maximum Current Sinking: 75mA
Inputs / Outputs	
Digital Inputs 1-8	0V return or 24 Vac **See Note 1
Analogue Inputs 1-8	Temperature Probe input ** See note 2
Universal IO 1-8	Analogue Input or Output ** See note 3
Relays 1-4	N/O, N/C and Common - Volt Free
Steppers 1-6	Out1B, Out1A, Out2A and Out2B Chopper current drive suitable for Bipolar (4-Wire) and Unipolar (6/8-Wire) stepper valves Max Valve Motor Power 8W Max Phase Current 580mA / 825mA peak
Stepper Power*	V1, No Connection (N/C) and V2 - An external AC or DC supply is required to operate the stepper output drives.*. Maximum supply current 5A
Module ID	Position 0 through to 9 - Select a unique ID for each expansion board in use**
Display	Not Currently Used
Status LED	Healthy LED - When powered up the LED will flash off/on every 0.5 seconds.



Please ensure all power is switched off before installing or maintaining this product.

## I/O Expansion Board (PR0661)

Power Requirements	
Supply Voltage Range	24VDC $\pm$ 10% or 24VAC $\pm$ 10%
Supply Frequency	DC or 50-60Hz $\pm$ 10%
Maximum Supply Current	1.5A
Typical Supply Current	<1A
General	
Operating Temperature Range	Without SSR fitted: -40°C to +60°C (-40°F to +140°F) With SRR fitted: -20°C to +60°C (-4°F to +140°F)
Operating Humidity	80% Maximum
Storage Temperature Range	Without SSR fitted: -40°C to +65°C (-40°F to +149°F) With SSR fitted: -30°C to +65°C (-22°F to +149°F)
Environmental	Indoor use at altitudes up to 2000m, pollution degree 2, installation category II.
Dimensions – L x W x H	280mm (11in) x 122mm (4.8in) x 67mm (2.6in)
Safety	EN 61010-1:2010
IP Rating	IP20
EMC	EN 61326-1:2013 FCC CFR 47 Parts 15.107 & 15.109 and ICES-003 Issue 6
Ventilation	There is no requirement for forced cooling ventilation
Class 2 Insulation	<b>No</b> protective Earth is required. A functional Earth may be fitted in noisy environments.
Supply Fuse	Built-In: 2A 240VAC Anti Surge (T) HRC conforming to IEC60127, 32x6.3mm
External MCB	2A 240VAC Type D conforming to BS EN 60898
Mechanical Relays	
Max Current	10A Resistive Load ( $\cos \theta = 1$ )
Max Voltage	250VAC, 24VDC
Built-In Relay Fuse	10A 240Vac Anti Surge (T) HRC conforming to IEC60127, 32x6.3mm
Relay Spacing	Relays <b>1-6</b> must together be either <b>all</b> mains or <b>all</b> low voltage. Relays <b>7-12</b> independently allow the use of mains or low voltage on any relay.
Solid State Relays	
Max Current	1Arms (1A Fuse if Applicable)
Voltage	12-280VAC (Not DC Voltage Compatible)
PWM Outputs	
Frequency Range	0.016667Hz - 20kHz
Period Limits	Min: 50 $\mu$ s Max: 60s
Period Resolution	10 $\mu$ s
Duty Cycle Range	0 - 100%
Internal Pull-Up Enabled	High-Level Output Voltage: Typical 4.7V $\pm$ 200mV (Recommended minimum 10k $\Omega$ load impedance)
Internal Pull-Up Disabled	External Voltage Range: 1V - 30V DC Maximum Current Sinking: 75mA
Inputs / Outputs	
Digital Inputs 1-8	0V return or 24 Vac <b>**See Note 1</b>
Analogue Inputs 1-8	Temperature Probe input <b>** See note 2</b>
Universal IO 1-8	Analogue Input or Output <b>** See note 3</b>
Relays 1-12	N/O, N/C and Common - - Volt Free
Module ID	Position 0 through to 9 - Select a unique ID for each expansion board in use <b>**</b>
Display	Not Currently Used
Status LED	Healthy LED - When powered up the LED will flash off/on every 0.5 seconds.



Please ensure all power is switched off before installing or maintaining this product.

## 48 Input Expansion Board (PR0662)

Power Requirements	
Supply Voltage Range	24VDC $\pm 10\%$ or 24VAC $\pm 10\%$
Supply Frequency	DC or 50-60Hz $\pm 10\%$
Maximum Supply Current	1.5A
Typical Supply Current	<1A
General	
Operating Temperature Range	-40°C to +60°C (-40°F to +140°F)
Operating Humidity	80% Maximum
Storage Temperature Range	-40°C to +65°C (-40°F to +149°F)
Environmental	Indoor use at altitudes up to 2000m, pollution degree 2, installation category II.
Dimensions – L x W x H	280mm (11in) x 122mm (4.8in) x 67mm (2.6in)
Safety	EN 61010-1:2010
IP Rating	IP20
EMC	EN 61326-1:2013 FCC CFR 47 Parts 15.107 & 15.109 and ICES-003 Issue 6
Ventilation	There is no requirement for forced cooling ventilation
Class 2 Insulation	<b>No</b> protective Earth is required. A functional Earth may be fitted in noisy environments.
Supply Fuse	Built-In: 2A 240VAC Anti Surge (T) HRC conforming to IEC60127, 32x6.3mm
External MCB	2A 240VAC Type D conforming to BS EN 60898
Inputs / Output	
Analogue Inputs 1-48	Temperature Probe input ** See note 2
Universal IO 1-8	Analogue Input or Output ** See note 3
Module ID	Position 0 through to 9 - Select a unique ID for each expansion board in use**
Display	Not Currently Used
Status LED	Healthy LED - When powered up the LED will flash off/on every 0.5 seconds.



Please ensure all power is switched off before installing or maintaining this product.

## Mini IO Expansion Module (PR0663 / PR0663 4-4)

Power Requirements	
Supply Voltage Range	24VDC $\pm$ 10% or 24VAC $\pm$ 10%
Supply Frequency	DC or 50-60Hz $\pm$ 10%
Maximum Supply Current	0.25A
Typical Supply Current	<0.15A
General	
Operating Temperature Range	Without SSR Fitted: -40°C to +60°C (-40°F to +140°F) With SRR fitted: -30°C to +60°C (-22°F to +140°F)
Operating Humidity	80% Maximum
Storage Temperature Range	Without SSR Fitted: -40°C to +65°C (-40°F to +149°F) With SSR fitted: -30°C to +65°C (-22°F to +149°F)
Environmental	Indoor use at altitudes up to 2000m, pollution degree 2, installation category II.
Dimensions – L x W x H	52.5mm (2in) x 134mm (5.2in) x 70mm (2.8in)
Safety	EN 61010-1:2010, UL 62368-1
IP Rating	IP20
EMC	EN 61326-1:2013 FCC CFR 47 Parts 15.107 & 15.109 and ICES-003 Issue 6
Ventilation	There is no requirement for forced cooling ventilation
Class 2 Insulation	No protective Earth is required.
External Supply Fuse	2A 240VAC Anti Surge (T) HRC conforming to IEC60127, 32x6.3mm
External MCB	2A 240VAC Type D conforming to BS EN 60898
Mechanical Relays	
Max Load Current	5A Resistive ( $\cos \theta = 1$ )
Max Load Voltage	250VAC, 30VDC
Relay Spacing	Relays <b>1 &amp; 2</b> must together be either mains or low voltage. Relays <b>3 &amp; 4</b> must together be either mains or low voltage.
Solid State Relays (factory fitted option)	
Max Load Current	1Arms
Min Load Current	0.025Arms
Load Voltage Range	20-280VAC (Not DC Voltage Compatible)
Inputs / Outputs	
Universal Inputs 1-4	Analogue Input or Output ** See note 3
Relays 1-5	N/O, N/C and Common - Volt Free
Module ID	Position 0 through to 9 - Select a unique ID for each expansion board in use**



Please ensure all power is switched off before installing or maintaining this product.

## Mini IO Expansion Module (PR0663 8P-4E)

Power Requirements	
Supply Voltage Range	24VDC $\pm$ 10% or 24VAC $\pm$ 10%
Supply Frequency	DC or 50-60Hz $\pm$ 10%
Maximum Supply Current	0.25A
Typical Supply Current	<0.15A
General	
Operating Temperature Range	-30°C to +60°C (-22°F to +140°F)
Operating Humidity	80% Maximum
Storage Temperature Range	-30°C to +65°C (-22°F to +149°F)
Environmental	Indoor use at altitudes up to 2000m, pollution degree 2, installation category II.
Dimensions – L x W x H	52.5mm (2in) x 134mm (5.2in) x 70mm (2.8in)
Safety	EN 61010-1:2010, UL 62368-1
IP Rating	IP20
EMC	EN 61326-1:2013 FCC CFR 47 Parts 15.107 & 15.109 and ICES-003 Issue 6
Ventilation	There is no requirement for forced cooling ventilation
Class 2 Insulation	No protective Earth is required.
External Supply Fuse	2A 240VAC Anti Surge (T) HRC conforming to IEC60127, 32x6.3mm
External MCB	2A 240VAC Type D conforming to BS EN 60898
Solid State Relays	
Max Load Current	1Arms
Min Load Current	0.025Arms
Load Voltage Range	20-280VAC (Not DC Voltage Compatible)
Inputs / Outputs	
Universal Inputs 1-4	Analogue Input or Output ** See note 3
Relays 1-5	N/O, N/C and Common - Volt Free
Module ID	Position 0 through to 9 - Select a unique ID for each expansion board in use**

## Mini IO Expansion Module (PR0681)

Power Requirements	
Supply Voltage Range	24VDC $\pm$ 10% or 24VAC $\pm$ 10%
Supply Frequency	DC or 50-60Hz $\pm$ 10%
Maximum Supply Current	1.0A
Typical Supply Current	<0.25A
General	
Operating Temperature Range	Without SSR Fitted: -40°C to +60°C (-40°F to +140°F) With SRR fitted: -30°C to +60°C (-22°F to +140°F)
Operating Humidity	80% Maximum
Storage Temperature Range	Without SSR fitted: -40°C to +65°C (-40°F to +149°F) With SSR fitted: -30°C to +65°C (-22°F to +149°F)
Environmental	Indoor use at altitudes up to 2000m, pollution degree 2, installation category II.
Dimensions – L x W x H	101mm (3.87") x 157mm (6.18") x 67mm (2.63")
Safety	EN 61010-1:2010, UL 62368-1
IP Rating	IP20
EMC	EN 61326-1:2013 FCC CFR 47 Parts 15.107 & 15.109 and ICES-003 Issue 6
Ventilation	There is no requirement for forced cooling ventilation
Class 2 Insulation	No protective Earth is required.
External Supply Fuse	2A 240VAC Anti Surge (T) HRC conforming to IEC60127, 32x6.3mm
External MCB	2A 240VAC Type D conforming to BS EN 60898



Please ensure all power is switched off before installing or maintaining this product.

<b>Mechanical Relays</b>	
Max Load Current	5A Resistive ( $\cos \theta = 1$ )
Max Load Voltage	250VAC, 30VDC
Relay Spacing	Relays <b>1 &amp; 2</b> must together be either mains or low voltage. Relays <b>3 &amp; 4</b> must together be either mains or low voltage.
<b>Solid State Relays (factory fitted option)</b>	
Max Load Current	1Arms
Min Load Current	0.025Arms
Load Voltage Range	20-280VAC (Not DC Voltage Compatible)
<b>Inputs/Outputs</b>	
Analogue Input or Output	See note 3
Module ID	Position 0 through to 9, elect a unique ID for each expansion board in use**
Digital Inputs 1-4	0V return or 24 Vac, See note 1
Probe Inputs 1 to 6	Temperature Probe/Plant input, configurable in application software.
PWM Outputs 1 to 2	Pulse Width Modulation Output (PWM) for use with TDB software only.



Please ensure all power is switched off before installing or maintaining this product.

## Intuitive Stepper Module with Auto Close (PR0653 / PR0653-C)

Power Requirements						
Supply Voltage Range	24VDC $\pm$ 10% or 24VAC $\pm$ 10%					
Supply Frequency	DC or 50-60Hz $\pm$ 10%					
Maximum Supply Current	0.3A (Not Including Stepper Current)					
Typical Supply Current	<0.15A (Not Including Stepper Current)					
Maximum Supply Current	1A (Running 8W Stepper Valve at 24VDC)					
General						
Operating Temperature Range	0°C to +50°C (32°F to +122°F)					
Operating Humidity	80% Maximum					
Storage Temperature Range	0°C to +65°C (32°F to +149°F)					
Environmental	Indoor use at altitudes up to 2000m, pollution degree 2, installation category II.					
Dimensions - L x W x H	52.5mm (2in) x 134mm (5.2in) x 70mm (2.8in)					
Approx. Mass	165g					
Safety	EN 61010-1:2010 UL 62368-1 (Not yet Certified)					
IP Rating	IP20					
EMC	EN 61326-1:2013 FCC CFR 47 Parts 15.107 & 15.109 ICES-003 Issue 6					
Ventilation	There is no requirement for forced cooling ventilation					
Insulation	Class III. No protective Earth is required.					
External Supply Fuse	2A Anti Surge (T) HRC conforming to IEC60127					
External Supply MCB	2A Type D conforming to BS EN 60898					
Mechanical Relay						
Max Contact Current	3A (cos $\theta$ = 1)      2A (cos $\theta$ = 0.6)					
Max Contact Voltage	250VAC, 30VDC					
Stepper Output						
Chopper current drive suitable for Bipolar (4-Wire) and Unipolar (6/8-Wire) stepper valves						
Max Valve Motor Power	8W					
Max Phase Current	580mArms / 825mA peak					
Valve Closure Power Reserve						
Maximum Charge Time	450 seconds (7min 30sec)					
Typical Charge Time	380 seconds (6min 20sec)					
	<ul style="list-style-type: none"> <li>Charge times apply to supercapacitors that have been completely discharged.</li> <li>A full valve closure is possible even if the module is not completely charged depending on the valve's energy usage.</li> <li>The relay output is controlled using TDB under normal operating conditions however if a power fail is detected the relay is de-energised. This allows the relay to function as a power fail alarm by being set permanently on in TDB until a power fail overrides this and disables it.</li> </ul>					
LED Functions						
Status	Flash green when module is active.					
Reset	Solid red when module is in reset.					
Relay	Solid blue when relay is energized.					
Charge	Flash green when module is charging - pulse length proportional to charge level. Solid green when module is charged.					
Power Fail	Flash red when power to the module has been interrupted.					
Guaranteed Closure Valve list						
<b>ALCO</b>	EX4	EX5	EX6			
<b>SPORLAN</b>	SEI 0.5-11	SEI 30/50	SHE 100/175	SER 1.5-20	SER G/J/K	SER AA/A/B/C/D
<b>DANFOSS</b>	ETS 12.5-25B	ETS 50B	ETS 100B	ETS 250/400		
<b>CAREL</b>	E2/5/6V	E3/4/7V				
Note: guaranteed valve closure subject to configuration of valve parameters						



Please ensure all power is switched off before installing or maintaining this product.

**Note 1:** 24 Vac must have the same 24 Vac return as the supply voltage. If using the Plant controller 24V power supply only the 24Vac signal from the supply is required for the digital input. If using an external 24V power supply to signal a status change then both a common (0V) and status input signal (24V) is required for the appropriate digital input.

**Note 2:** A variety of probes can be used by the Data Builder Analogue block or a custom probe curve can be programmed.

**Note 3:** The Universal Inputs/Outputs are configured through the Plant controller TDB software. Each universal IO can be set as either:

- 0-10 Volts DC Input or
- 0-10 Volts DC Output or
- 4-20ma Output or
- 4-20mA Input (4-20mA current loop, use the 12 Vdc output to feed the 4-20mA device.)

**Note 4: \*Important**

- **If a 24v AC supply is used to power the stepper expansion board, the same AC supply cannot be used to power the stepper valve, the stepper valve requires its own separate power supply.**
- **If a 24V DC supply is used however, it can be used to power both the stepper expansion board and the stepper valve.**

**Note 5:** If using an Intuitive TDB, rotary switch position 1 refers to board 1. If using Intuitive Pack (SUP, CO2 etc.) rotary switch position 0 refers to board 1. Please refer to the appropriate controller user guide with regards to mapping the available inputs/ outputs on a desired expansion board to a Plant controller.

To meet UL (Underwriters Laboratories) compliance, the equipment must be powered by external power supply or power source via terminal connectors which circuits shall be compliant with the requirements of ES1 and PS2 (LPS) circuits.



Please ensure all power is switched off before installing or maintaining this product.

## Installation

### Mounting on to a DIN rail.

The Intuitive controller has two or three DIN rail mounting feet which can slide in and out to three different positions, sliding into each position is accompanied by a “click” which locks the foot into that position.

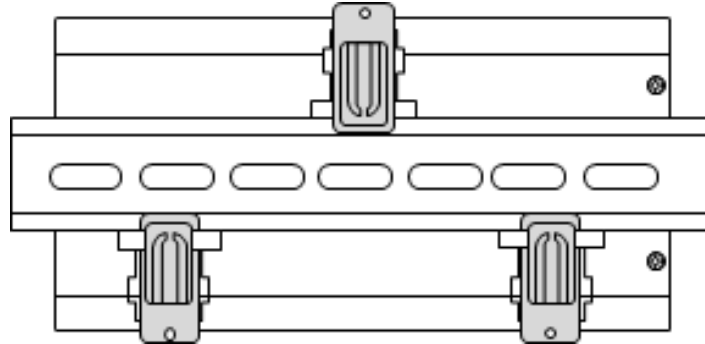

To install the controller onto a DIN mounting rail, from the fully pushed in position slide the top mounting foot out by 2 clicks so that the foot is clear of the DIN rail channel. Slide the bottom two feet out by one click so that they are protruding slightly into the DIN rail channel. The controller can now be inserted onto the DIN rail by inserting the bottom lip of the DIN rail behind the two bottom mounting feet.

The controller can now be pushed flat onto the DIN rail and the top foot pushed in 2 clicks to hold the controller in place. Finally, push the bottom foot (or feet) in by one click to secure the controller.

The mounting feet also have M3 holes for direct mounting where DIN rail is not being used.



Please ensure all power is switched off before installing or maintaining this product.

## Group Offices

### RDM Group Head Office

80 Johnstone Avenue  
Hillington Industrial Estate  
Glasgow  
G52 4NZ  
United Kingdom

+44 (0)141 810 2828  
[support@resourcedm.com](mailto:support@resourcedm.com)

### RDM USA

9441 Science Center Drive  
New Hope  
Minneapolis  
MN 55403  
United States

+1 612 354 3923  
[usasupport@resourcedm.com](mailto:usasupport@resourcedm.com)

### RDM Asia

Sky Park at One City  
Jalan USJ 25/1  
47650 Subang Jaya  
Selangor  
Malaysia

+60 3 5022 3188  
[asiatech@resourcedm.com](mailto:asiatech@resourcedm.com)



Visit [www.resourcedm.com/support](http://www.resourcedm.com/support) for more information on RDM solutions, additional product documentation and software downloads.

While every effort is made to ensure the information given within this document is accurate, Resource Data Management Ltd shall not be liable for errors or omissions, for incidental or consequential damages, directly or indirectly, in connection with the furnishing, performance or misuse of this product or document. All specifications are subject to change without notice. See [www.resourcedm.com](http://www.resourcedm.com) for terms and conditions of sales.