

Resource
Data Management

Bluetooth Temperature Probe

Commissioning/User Guide
Revision 1.2a



PR0633 / PR0636

Contents

Bluetooth Temperature Probe	3
Ordering Information.....	3
Enclosure.....	4
Current Status.....	5
Wireless Probe Example System	5
Bluetooth Setup on a DMTouch	6
Bluetooth Access Points	7
PR0632-DIN	7
PR0632-SF	8
IP Configuration	10
Multiple Bluetooth Access Points.....	10
Bluetooth Probe Configuration & Status	11
RDM App	11
Connecting to a Bluetooth Probe	12
Configuring a Bluetooth Probe.....	12
Viewing the status of a Bluetooth Probe	14
Modifying a Bluetooth Probe	14
About	15
Settings	15
Downloading the App.....	15
Logging on a Bluetooth Probe to the DMTouch or MiniDM	16
Parameter Table	17
Network Alarms	17
Maximum Number of Devices per Network	17
Data Builder	18
Technical Specification.....	19
Technical Specifications – PR0632-SF/RPT/DIN.....	20
Related Part Numbers.....	21
Battery Installation PR0633	23
Cleaning	23
Mounting and Installation Instructions PR0633	25
Mounting and Installation Instructions PR0636	26
Network Repeater	27
PR0632-SF-RPT.....	27
Disclaimer.....	28
Warranty Information	28
Revision History	28

Before installing or using this product, read the contents of this guide thoroughly to familiarise yourself with all the operating parameters and features. Please refer to the information detailed in the [Technical Specification](#) section.



Please ensure all power is switched off before installing or maintaining this product.

Bluetooth Temperature Probe

From Resource Data Management

The RDM Bluetooth Probe is a battery powered device for use in temperature monitoring applications and is available in two hardware versions. RDM part number PR0633 is a complete enclosed unit designed to be fitted in the area to be monitored and can operate in the temperature range of -30°C (-22°F) up to + 50°C (122°F).

The PR0636 uses an external temperature probe (supplied separately) and is designed to be fitted away from the area to be monitored, on top of a cold-room for example and can operate in the range of -5°C to +50°C (23°F to +122°F). The external temperature probe connected to it however can operate in a range of -90° to 128° C but this is limited by the temperature range of the probe type being used, (the RDM PT1000 probe for example has a range of -40° to 80° C). Ten different probe types can be used; PT1000, NTC2K, 470R, 700R, 3K, 5K, 6K, NTC2K25, NTC10K or NTC10K (2), the probe type is selected using the RDM App. See:

[Downloading the App](#)

The Bluetooth Probe has an over and under temperature alarm set point with an associated alarm delay. The Bluetooth Probe uses the latest Bluetooth mesh technology which allows it to integrate to an existing RDM Bluetooth Mesh solution, although the Probe itself is not a Mesh device. To optimise battery life the device 'wakes up' every 10 minutes to sample the temperature before sending the data to an RDM DMTouch or miniDM. The Probe is logged on to a DMTouch or miniDM front end system, via a Bluetooth Access Point (PR0632-SF or PR0632-DIN). This allows for temperature monitoring without the need for a full site wired network infrastructure. This provides greater flexibility for monitoring solutions in applications where the installation of a wired network isn't feasible or cost effective.

The configuration of the Bluetooth probe is made simple by utilising Near Field Communications (NFC) and the free to download RDM App**.

The Bluetooth Probe has a unique feature which allows it to store up to 7 days of temperature data. This data is stored should the unit lose communication with the DMTouch or on which it is networked. When communications are restored, the logged data will be uploaded from the Probe to the DMTouch or miniDM thus the user can review the logged temperature data for the period of time the Probe was offline.

Note: Bluetooth is only available from DMTouch software version v3.2.1 and above and miniDM software version v4.1

Note: Bluetooth is only available from Intuitive TDB and Mini Intuitive TDB software version V4.2 and above.

* Battery not included in 5-year warranty.

**RDM App available for Android and iOS devices capable of NFC.

Ordering Information

Part Number	Description
PR0633	Bluetooth Temperature Probe
PR0633-OS	Bluetooth Temperature Probe for non-UK use
PR0636	Bluetooth Temperature monitor with external Probe (external probe not included)
PR0636-OS	Bluetooth Temperature monitor with external Probe for non-UK use
BA0006	Replacement Lithium Battery ½ size AA for PR0633
BA0007	Replacement Battery AA size for PR0636 (2 required per unit)

Note: - The Bluetooth Temperature Probe PR0633 is supplied with a ½ size AA 3.6V Lithium Battery (**UK Only**) RDM Part Number BA0006. The PR0636 is supplied with 2 x AA batteries (**UK Only**) RDM Part Number BA0007.

The PR0633 has a magnetic mounting base and is supplied with a wall mounting bracket for use on non-magnetic surfaces.



Please ensure all power is switched off before installing or maintaining this product.

The PR0636 is supplied with external mounting lugs only and has an internal battery holder.

Enclosure

PR0636

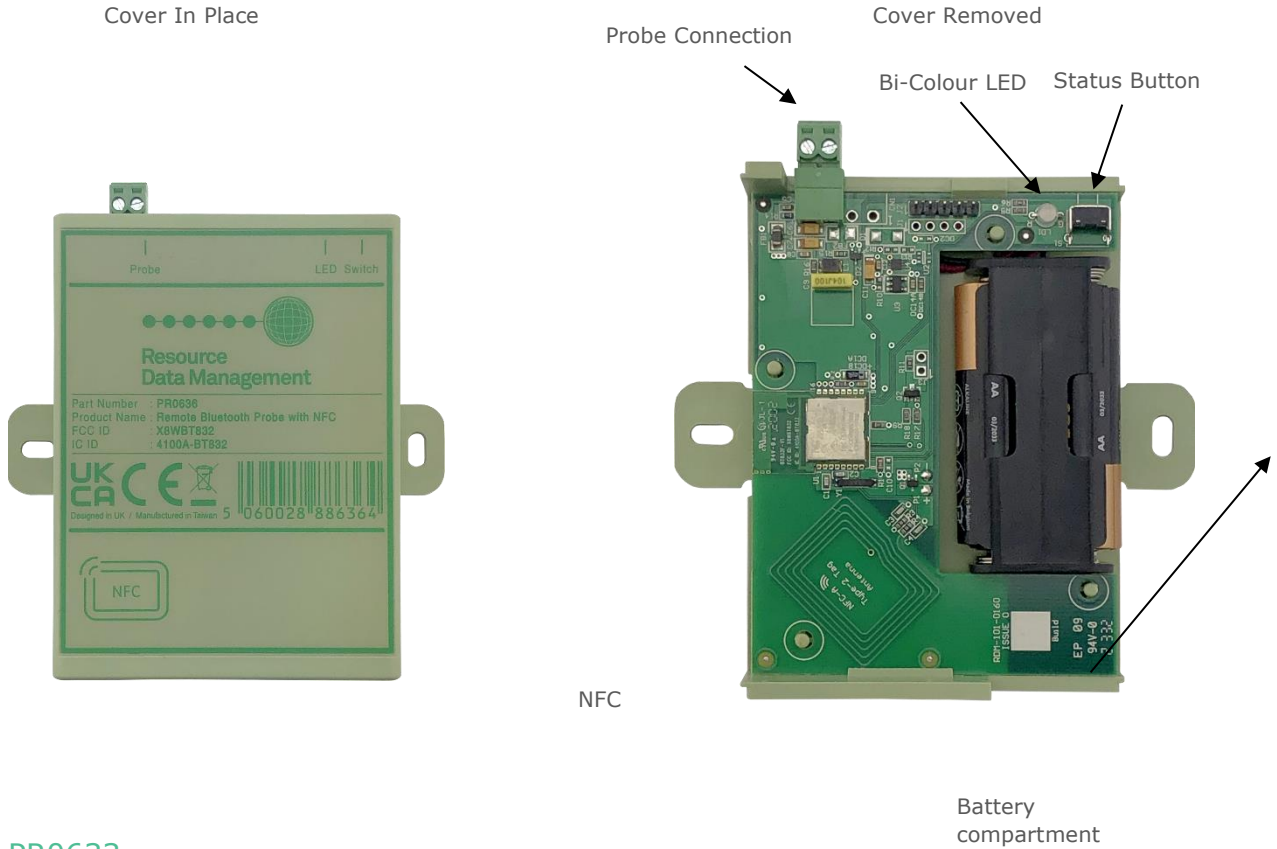

PR0633

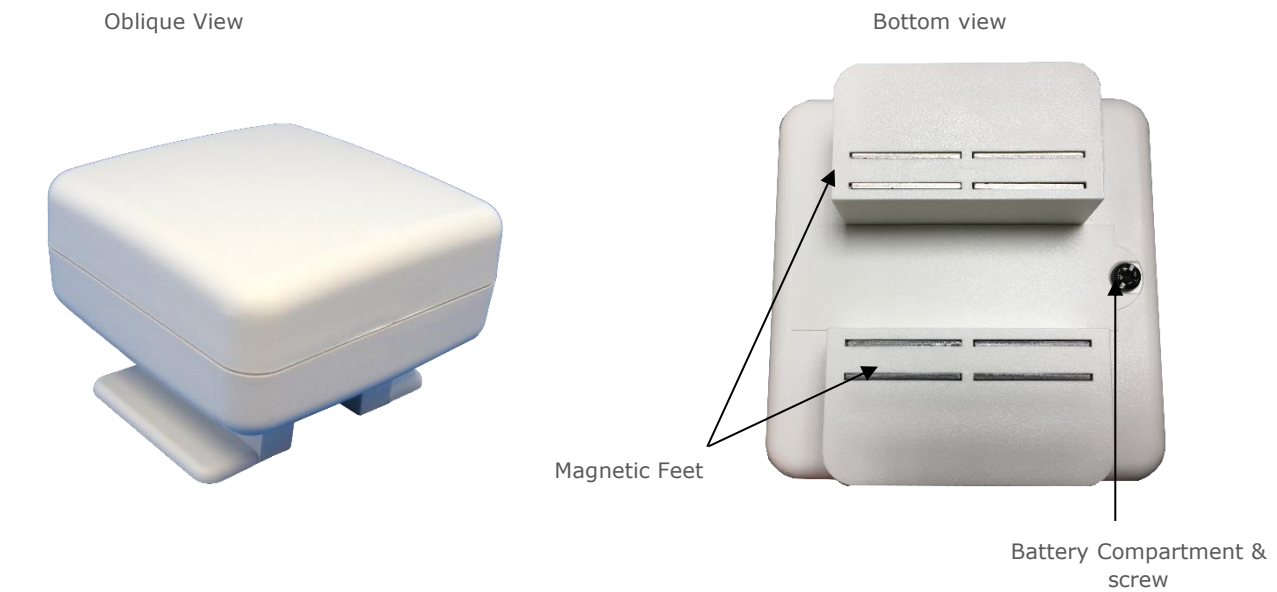

The unit has magnetic feet which allow for quick and easy installation. The compartment has an internal rubber seal which requires the cover to be securely fitted to achieve the maximum IP rating.



Please ensure all power is switched off before installing or maintaining this product.

Removing the bottom cover will reveal the battery compartment, push button and bi-colour LED as shown in the below image.

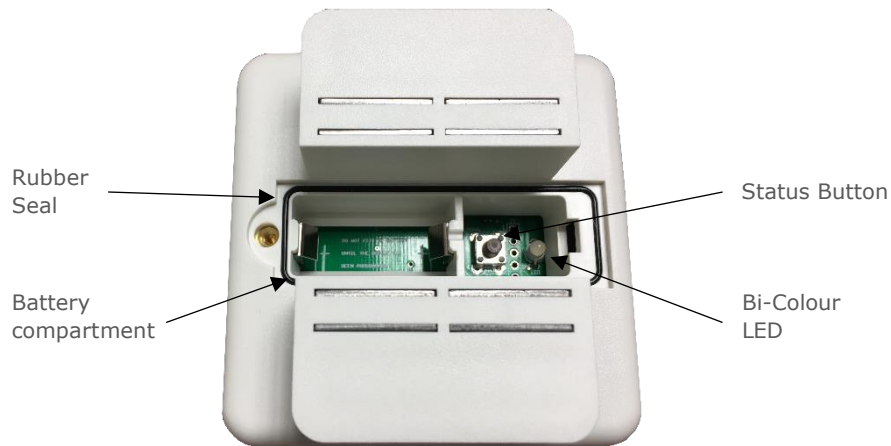

Current Status

The status of the Bluetooth Probe can be viewed by either using the RDM App or by using the push button and status LED from within either device. See [Enclosure](#) section for access. For details using the App please see [Probe Configuration & Status](#).

A single press of the push button at any time will provide an indication to the Bluetooth Probes state:

LED Signal	Status
1 green, 3 red flashes	Device is un-configured (has no ID) or has failed to log on to network.
2 green, 2 red	Device is configured with an ID and is attempting to get a network address.
3 green, 1 red	Device has an address, currently no friend*
4 green	Device has an address, currently has a friend*

*Note: A friend is deemed a Network repeater

Wireless Probe Example System

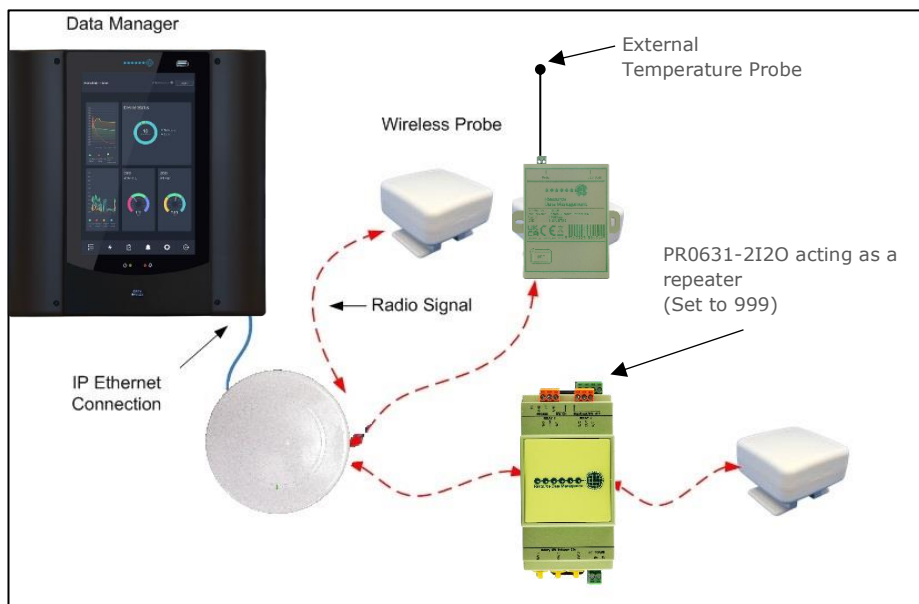

In the example shown a number of Wireless Probes are connected to a DMTouch/miniDM via a Bluetooth Access Point. The Access Point is connected to the DMTouch or miniDM’s Ethernet 0 IP network via an ethernet patch cable (see section on [Bluetooth Access Point](#)). The Wireless Probe transmits data to/ from the Bluetooth Access Point as a radio signal. The Access Point in turn passes the data on to the DMTouch/miniDM via its



Please ensure all power is switched off before installing or maintaining this product.

Ethernet network connection. This same process allows the DMTouch/miniDM to send data to the Wireless Probes.

Bluetooth Setup on a DMTouch

From the Service Menu select: Devices/ Network/ RDM Bluetooth Wireless Mesh

The following guide should be used to configure an RDM Bluetooth Access Point for use with a DMTouch/miniDM. Up to 4 Bluetooth Access Points can be connected to the DMTouch/miniDM's Ethernet 0 network. This is advantageous should the wireless network be split across multiple floors in a building.

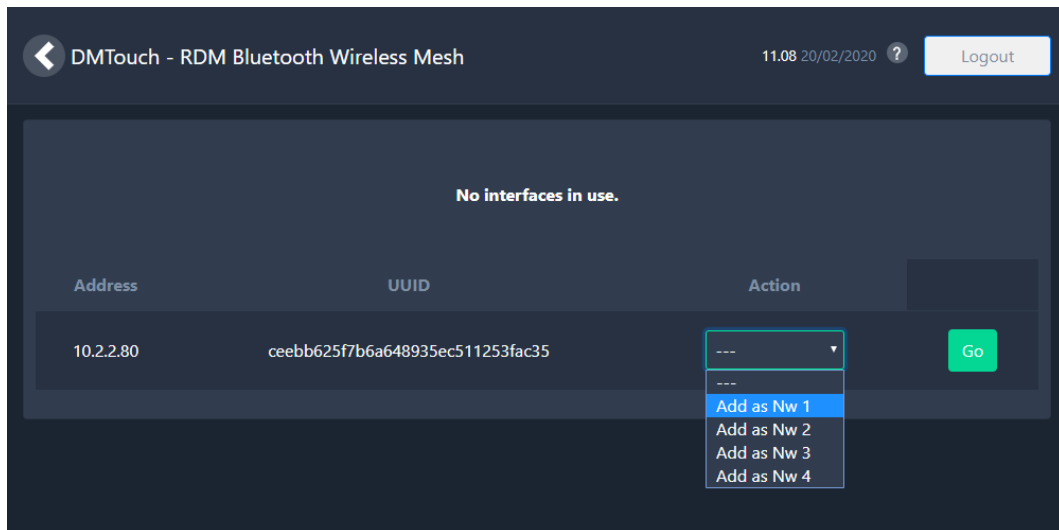

Shown above is an example screenshot from the DMTouch/miniDM's Bluetooth Setup page. It shows no current interfaces in use and a single Bluetooth Access Point that has not yet been configured. As mentioned above up to 4 Bluetooth Mesh networks can operate simultaneously. The first step is to set the Access Point's Network number from the 'Action' drop down menu and click 'Go'.

Once the unit has been added as a network it will list it in the below table.

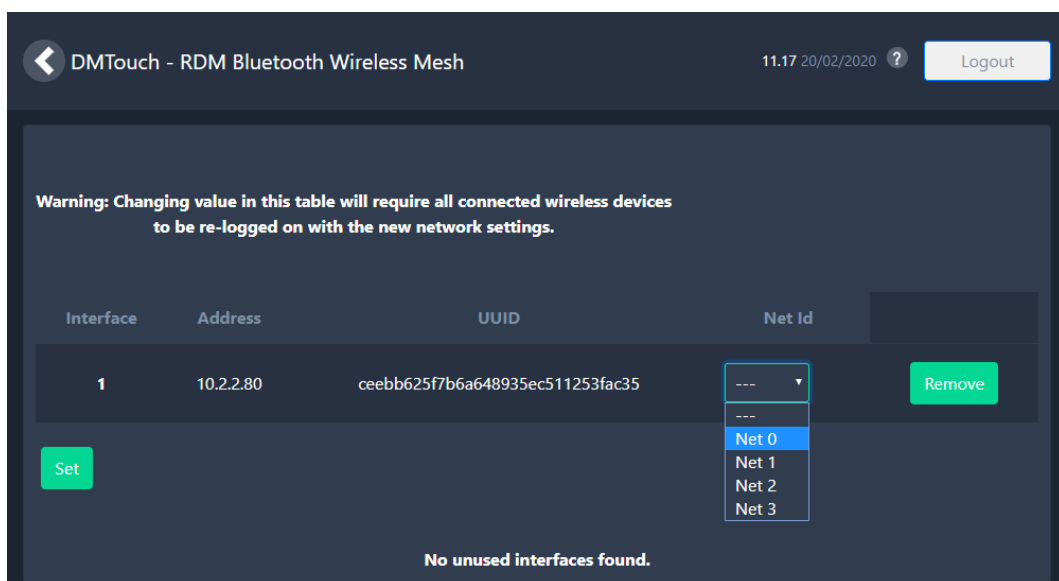

From here, select the desired Net ID (0 – 3) from the drop-down menu.

Note: Any Bluetooth mesh device to be used as a [repeater](#) for the DMTouch/miniDM via this Access Point must have its [network channel switch](#) set to the same Net ID selected for the Access Point.



Please ensure all power is switched off before installing or maintaining this product.

Press 'Set' to save any changes made. Now configure the wireless mesh device that is to be logged on to the DMTouch/miniDM.

Note: The software feature 'DMTouch/miniDM Bluetooth Mesh Software Enabler' (PR0635) will allow 32 devices to be logged on to the DMTouch/miniDM. This can be over a single Access point or multiple Access points. A DMTouch can support up to 64 Bluetooth devices and the miniDM a maximum of 32.

Bluetooth Access Points

The Bluetooth Access Point comes in two hardware platforms both similar in function; A PR0632-DIN or a PR0632-SF. Both units are setup using the same method.

Note: The access point should be connected and powered up before adding Bluetooth devices.

PR0632-DIN

The DIN rail mountable PR0632-DIN has the below connections.

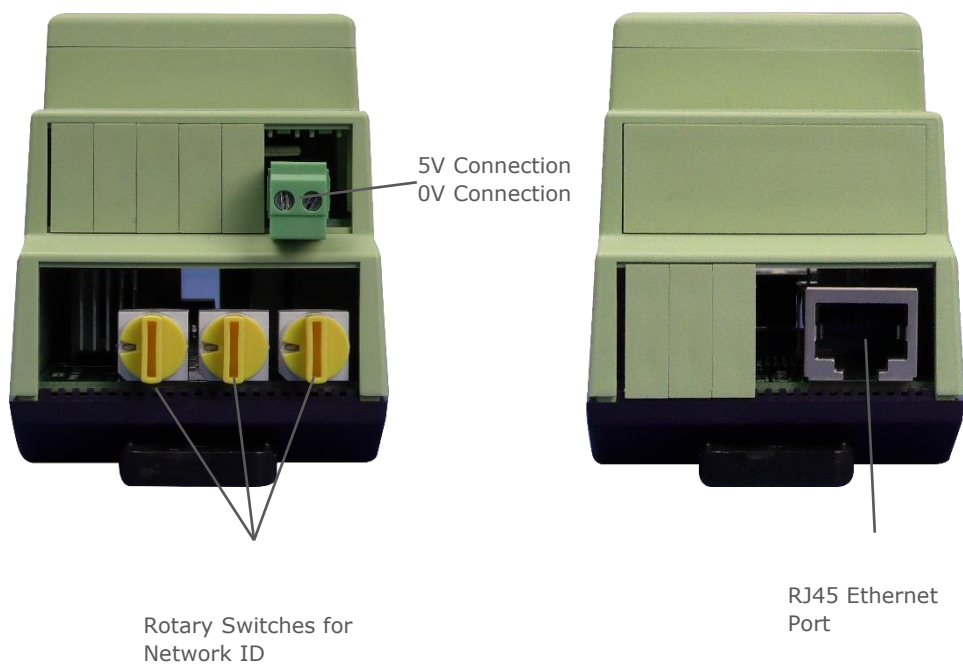

Please ensure all power is switched off before installing or maintaining this product.

The gateway itself must be powered by a 5Vdc supply and connected to the DMTouch or miniDM via a standard Ethernet IP network.

The three rotary switches can be adjusted depending on the network it is connected. See [IP Configuration](#) for more details.

From this point the gateway must be configured as outlined in the [Bluetooth Mesh Setup on a Data Manger](#) section.

Note: - The PR0632-DIN comes supplied with a 5v Din Rail mount PSU

PR0632-SF

The wall mountable PR0632-SF has the below connections.



The PR0632-SF has the options of being powered by either a 5Vdc supply or by using Power over Ethernet (PoE) and then connected to the DMTouch or miniDM via a standard Ethernet IP network. RDM's PoE injector kit can be utilised to supply power (PR0619).

The three rotary switches can be adjusted depending on the network it is connected. See [IP Configuration](#) for more details.

From this point the gateway must be configured as outlined in the [Bluetooth Mesh Setup on a Data Manger](#) section.

Note: - The PR0632-SF comes supplied with a 5v External Desktop PSU



Please ensure all power is switched off before installing or maintaining this product.

Option 1 – Direct Power Supply – PR0632-DIN/ PR0632-SF

There are two methods to which the Bluetooth Access Point can be connected to a DMTouch or miniDM. For illustration purposes only the DMTouch is shown below. The first, simply uses its IP interface to directly connect to the DMTouch's Ethernet 0 IP network via an ethernet cable where the Bluetooth Access Point is powered from a direct power supply (5Vdc).



Option 2 – Power over Ethernet (PoE) – PR0632-SF

The second utilises the Power over Ethernet standard (PoE) where the POE Injector can be ordered (PR0619) separately. In this instance the Bluetooth Access Point is powered directly via the ethernet lead and would require no additional power supply. The PoE injector is powered separately and is connected directly to the Ethernet 0 network of the DMTouch (LAN IN). The second IP (LAN OUT) port of the injector will be to communicate and power the Bluetooth Access Point.

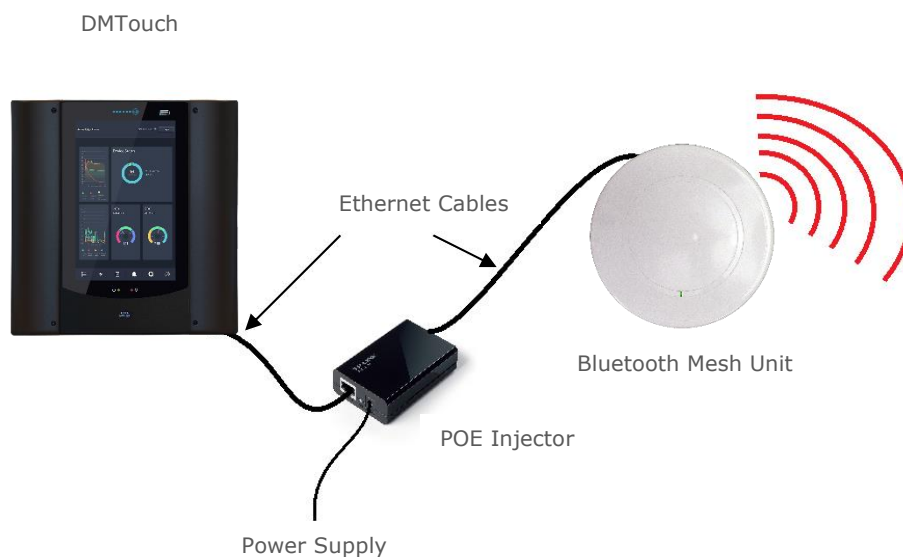

Please refer to the CAT5 standard with regards to maximum cable lengths. The POE injector will supply power up to 100m of cable.

Note: - The PR0632 does not come supplied with PoE (Power over Ethernet) injector.



Please ensure all power is switched off before installing or maintaining this product.

IP Configuration

For the Bluetooth Access Point to connect to a DMTouch/miniDM its IP address must be configured and connected to the Eth0 interface. The IP address of the module is dependent on the rotary switch positions. The table below shows the configuration.

Rotary Address	IP Address Range
001 to 254	The module is set to operate in the 10.1.2.XXX range with the last part of the IP address being a number between 1 and 254. The last part of the IP address determined by the rotary switch address entered. For example, if the rotary switch address is set to '150' then the module will be assigned the address 10.1.2.150.
301 to 555	The module is set to operate in the 192.168.0.XXX range with the last part of the IP address being a number between 1 and 254. The last part of the IP address is determined by the rotary switch address entered. Rotary address 301 equates to 1, 302 is 2 etc up to address 555 which is 254. If you add 300 to the last part of the desired IP address it will provide the required rotary switch setting. For example, if the desired IP address is '192.168.0.150' then the module rotary switch address will be '450'.
000 or 999	The module is set to DHCP mode and will request an IP address from network. Set '999' and power on the module.
Remaining Addresses	The remaining rotary switch addresses are reserved for future use and should not be used.

Multiple Bluetooth Access Points

The DMTouch can support up to four Bluetooth Access Points (any combination of PR0632-DIN and PR0632-SF). This is advantageous should the Bluetooth network be split across multiple floors in a building. Shown below is a simplified network configuration with two Bluetooth Access Points.

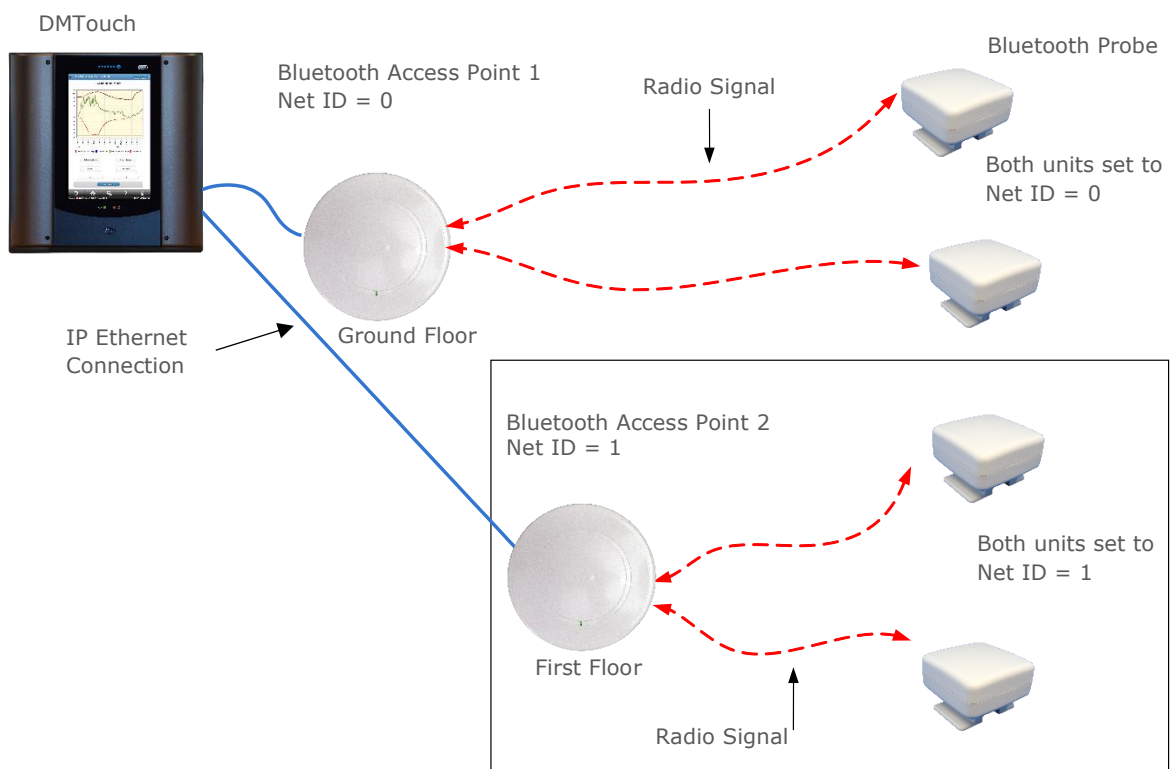

In the example above, two Bluetooth Access Points are connected to a DMTouch via Eth 0. One is configured as Net ID 0 and the other as Net ID 1. One is installed on the ground floor of a building and the other on the first floor. By setting the Net ID on the Wireless Temperature Probes to the appropriate Net ID (set within the DMTouch) the associated probes can be logged on to the desired Bluetooth Access Point.



Please ensure all power is switched off before installing or maintaining this product.

Bluetooth Probe Configuration & Status

The DMTouch must be configured prior to logging on any device.

To configure the Bluetooth probe the battery supplied (UK Only) with the PR0633 must first be inserted, the PR0636 is supplied with two AA size batteries which need to be inserted. Then the setup is carried out from within the RDM App.

RDM App

To begin, ensure NFC is active on the mobile device and then open the App*. When opening the app, the following screen will be displayed.



Please ensure all power is switched off before installing or maintaining this product.

Connecting to a Bluetooth Probe

To connect to the Bluetooth probe, press on the 'READ TAG' option and hold the mobile device closely over the probe. The App will then show the screen below as it tries to locate and connect to the Bluetooth probe. This will allow you to setup the Probe or read its current configuration.

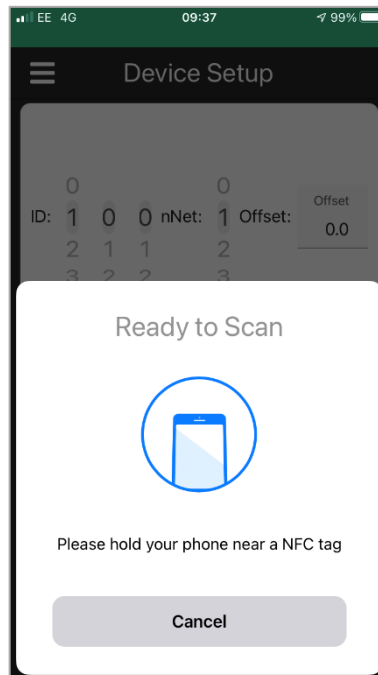

Configuring a Bluetooth Probe

Once the mobile device has connected to the probe, a screen like below is shown. This screen is used to read/edit the configuration of the probe and will also show the temperature of the probe at the time it was read. If the Probe has been previously configured you will see the current setup details of the Probe.



Please ensure all power is switched off before installing or maintaining this product.

To configure the Probe, firstly assign the network ID (0 – 3) to match the network ID setup within the DMTouch. For example, if adding a probe to a DMTouch/miniDM with the settings below then the 'Net' setting must be set to 1 in the app. Then assign the probe a unique Probe ID (000 – 999). And apply a temperature offset if required.

Within the DMTouch/miniDM Wireless Mesh setup screen the 'Enable Add Device' button must be pressed so that the DMTouch/miniDM will accept new devices to the network. Once pressed it will be active for 12 hours or until the panel is restarted.

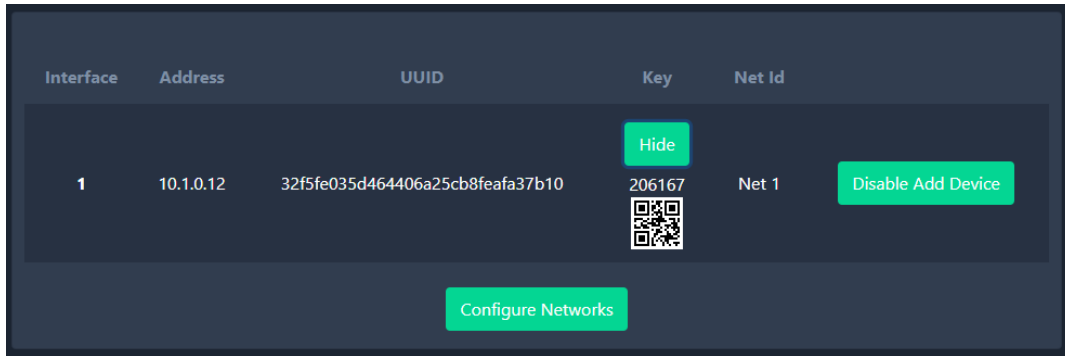

Note: - The 'Passcode' option does not need to be used in the initial setup, its only needs to be entered when modifying the probes settings.

The picture below is a Probe setup screen that has been configured with an ID and network ID and is ready to log on.

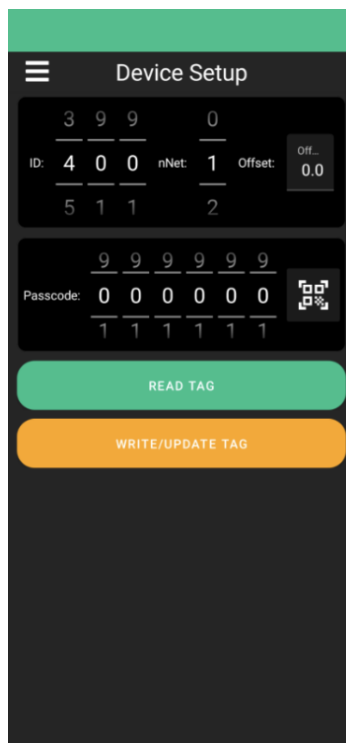

Once complete, hold the mobile device over the Bluetooth Probe and press the 'Write/Update Tag' to finalise the setup. The Probe will then use the ID and Passcode to log on to the DMTouch/MiniDM's Bluetooth network. It will then appear in the device list as WPRXXX where 'XXX' represents the device ID.

Device	Description	Value	Status	Pack	TPI
● WPR400	Training Room Probe 1	24.4 ⓘ	● Normal		



Please ensure all power is switched off before installing or maintaining this product.

Viewing the status of a Bluetooth Probe

The Status of the Bluetooth Probe can be read by the same method outlined above from within the app.

The details of the Network configuration, temperature reading along with other details will be shown. Using the 'refresh' symbol will clear any details read from the probe so to be ready for reading any others.

Modifying a Bluetooth Probe

For security, if you need change the probe configuration (i.e., ID, Net or Offset), you will need the Key Passcode from the DMTouch/miniDM. This can be found under the RDM Bluetooth Wireless Mesh menu in the DMTouch/miniDM. The user can manually enter the passcode key or use the QR Code feature which will read the code and populate the details.

Failure to enter the Passcode or an incorrect Passcode, will result in an error message appearing



Once all the information has been entered, press 'Write/Update Tag' to send the information. This will then update the information in the probe and those changes will be picked up by the DMTouch/miniDM. Pressing on the 'Read Tag' button will refresh the information to confirm it has been set.

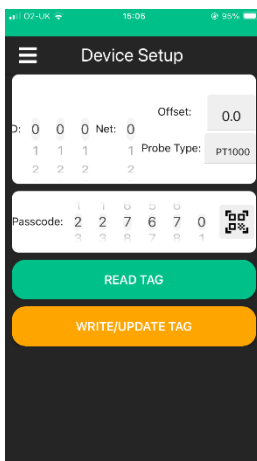
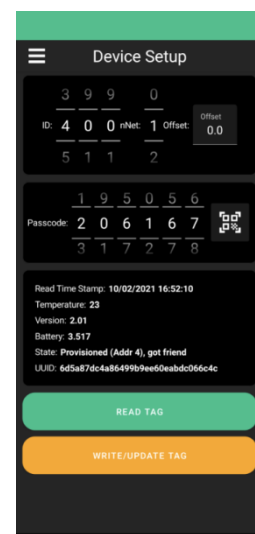

With the PR0636 with external probe there is an additional option to set the probe type, once the type has been selected press 'Write/Update Tag' to send the information. This will then update the information in the probe and the probe type will be picked up by the DMTouch/miniDM. Pressing on the 'Read Tag' button will refresh the information to confirm it has been set.

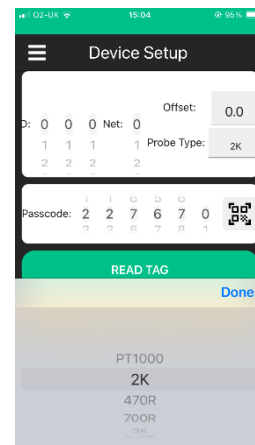

Note: - The passcode is only available in version 2.0.2 or above for the probe and 4.0 or above on the DMTouch/miniDM.



Please ensure all power is switched off before installing or maintaining this product.

Settings

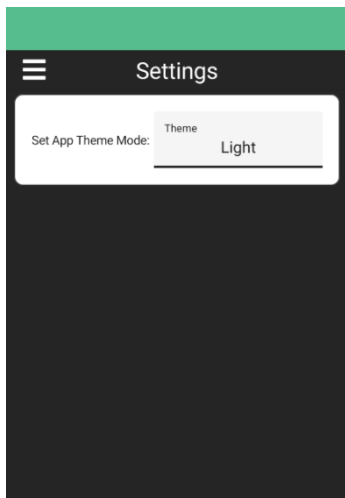

This screen will allow you to toggle the App between the Light and Dark theme.

About

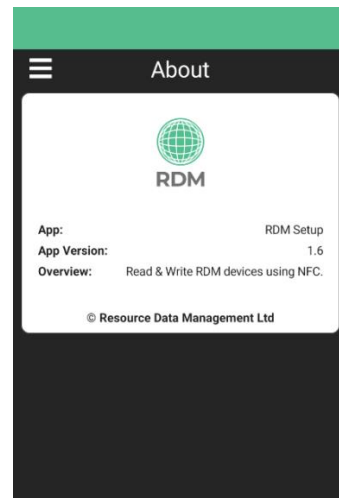

This screen shows you information about the App running (e.g. App Version)

***Note:** App may differ to the images shown above.

Downloading the App

Apple: - The App can be downloaded at <https://apps.apple.com/app/id1542795609> or by using the QR code below: -



Android: - The App can be downloaded at <https://play.google.com/store/apps/details?id=com.resourcedm.rdmsetup>



Please ensure all power is switched off before installing or maintaining this product.

Logging on a Bluetooth Probe to the DMTouch or MiniDM

The following steps should be followed when logging on a Wireless Probe to the DMTouch. The same process applies to the MiniDM.

See also [Mounting and Installation Instructions](#).

- Ensure the DMTouch has software version V3.2.1 or greater.
- Ensure the Bluetooth interface (PR0635) is enabled in the DMTouch's 'System Configuration'. **Note** a single PR0635 will allow up to 32 devices to log on. Multiple PR0635's will be needed if more than 32 Wireless Probes are required to be logged on.
- Configure and connect the [Bluetooth Access Point](#) to the [DMTouch](#)
- Configure the 'Bluetooth Network Setup' page in the [DMTouch](#)
- Configure the Bluetooth Probes as outlined in the [Configuration](#) section ensuring the Network ID matches that of the DMTouch and the Probe ID is unique.
- After a short duration the Bluetooth Probe will appear in the DMTouch's device list. At this point check and edit the [parameters](#) as required.

Device	Description	Value	Status	Pack	TPI
WPR400	Training Room Probe 1	24.4 ⓘ	Normal		

- Check the alarm delay in the DMTouch/MiniDM's Site Setup page. Since the Bluetooth Probe attempts to communicate with the DMTouch/MiniDM every 10 minutes the Offline Alarm delay should be no less than 22 minutes.
- The status of the Bluetooth Probe can be checked directly on the probe by viewing the [status LED](#) or by using the RDM App as detailed in the [Configuration](#) section. The address the probe has been given will be detailed in the Device Info page of the DMTouch/MiniDM
-

Device	Type	Version	CRC	Bitswitches	Address	ID	MAC
WPR400	2f000004	-----	----	----	0000000000000014	---	-----

If the wrong address has been entered into the Wireless Probe, use the method outline in the [Configuration](#) section to change the network and or Probe ID to the required settings. The device (with the incorrect ID) will need to be removed from the DMTouch/MiniDM's device list.

Note: When the unit is to be decommissioned it will still consume power therefore it is recommended to remove the battery.

Always attempt to logon the Wireless Probe from the location in which it will be fitted.

If a Wireless Probe is inadvertently removed from the DMTouch Device List by the user it will automatically log back on the next time the Wireless Probe reports its temperature data.



Please ensure all power is switched off before installing or maintaining this product.

Parameter Table

Once the Bluetooth Probe has been addressed and has logged onto a DMTouch or miniDM the following parameters can be reviewed and changed if necessary.

PR0633

Parameter	Range °C (°F)	Step	Units	Default °C (°F)	Comments
OT Alarm	-30 to +50 (-22 to +122)	0.1	Deg	5.0 (41)	Over temperature alarm setpoint
UT Alarm	-30 to +50 (-22 to +122)	0.1	Deg	-2.0 (28.4)	Under temperature alarm setpoint
Alarm Delay	0 to 99	1	mins	20	Alarm delay OT and UT alarms

PR0636

Parameter	Range °C (°F)	Step	Units	Default °C (°F)	Comments
OT Alarm	-90 to +128 (-130 to +260)	0.1	Deg	5.0 (41)	Over temperature alarm setpoint
UT Alarm	-90 to +128 (-130 to +260)	0.1	Deg	-2.0 (28.4)	Under temperature alarm setpoint
Alarm Delay	0 to 99	1	mins	20	Alarm delay OT and UT alarms

With the PR0626 the probe type can only be changed using the RDM App: [Downloading the App](#)
Probe type cannot be selected using the front end host device.

Network Alarms

The table below shows the text and associated type number that is sent to the DMTouch or miniDM. The type number is normally used to provide different alarm actions.

Alarm text	Type # (Index #)
Probe Over Temperature	4
Probe Under Temperature	5
Probe Fault	6

Maximum Number of Devices per Network

The RDM Bluetooth mesh solution is highly flexible and allows for up to **64** Bluetooth Mesh enabled devices to be connected to a DMTouch. The miniDM supports up to 32 Bluetooth devices.

Up to 4 Bluetooth Access Points can be connected to a single DMTouch or miniDM. A software enabler is required per 32 devices (PR0635).

Devices include the 2I20, 4I, wireless probes and comms modules.



Please ensure all power is switched off before installing or maintaining this product.

Data Builder

Using a TDB program running on a DMTouch/miniDM or Intuitive/Mini Intuitive TDB Controller, the user can pull in the temperature value from the Bluetooth Probe.

To read information into a TDB program, the user would use an Analog Input block with the following setup: -

- Type** This must be set to 'Network'.
- Device** Enter the controller's name as it appears in the device/network list e.g., 'WPR400'.
- Value** Enter the input you would like to pick up, making sure the name matches exactly the same as on the item is displayed (including upper- and lower-case characters)

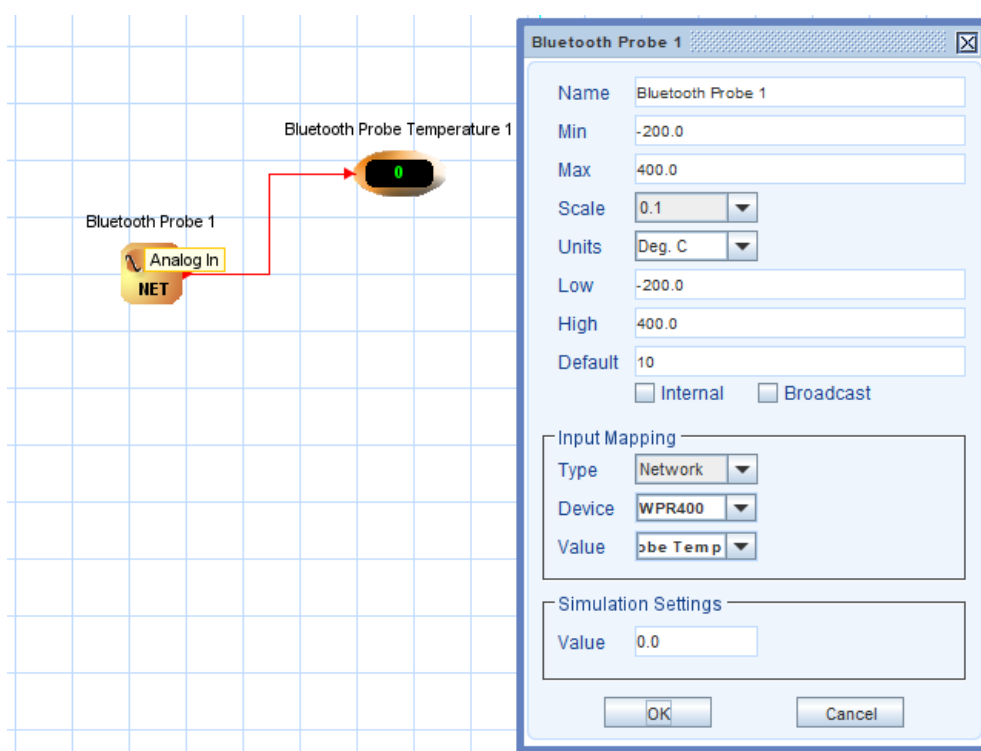

Please ensure all power is switched off before installing or maintaining this product.

Technical Specification

Note the product must be used as detailed by the manufacturer, failure to comply may result in incorrect operation of the product or premature failure.

Power Requirements	
Supply Voltage Range	PR0633 Battery Powered 3.6V (1/2 size AA Battery)
Supply Voltage Range	PR0636 Battery Powered 3.0V (2 x AA Battery)
Supply Frequency	DC
Maximum Supply Current	20mA
Sleep Supply Current	< 10ua
General	
Operating Temperature Range	PR0633 : -30°C to +50°C (-22°F to +122°F)
Operating Temperature Range	PR0636 : -5°C to +50°C (23°F to +122°F)
Operating Humidity	80% maximum
Storage Temperature Range	PR0633 : -35°C to +65°C (-31°F to +149°F)
Storage Temperature Range	PR0636 : -5°C to +65°C (23°F to +149°F)
Environmental	Indoor use at altitudes up to 2000m, pollution degree 2.
Dimensions – L x W x H	PR0633 : 75mm (3in) x 75mm (3in) x 52mm (2in)
Dimensions – L x W x H	PR0636 : 95mm (3.75in) x 97mm (3.8in) x 30mm (1.25in)
Approximate Weight	PR0633 : 154g (0.339lbs) including battery.
Approximate Weight	PR0636 : 120g (0.264lbs)
IP Rating	PR0633 : IP65
IP Rating	PR0636 : IP10
EMC	UKCA EN 61326-1: 2013 EN 55032: 2015 ETSI 301 489-1 V2.2.3 ETSI 301 489-17 V3.1.1 ICES-003 Issue 6
Ventilation	There is no requirement for forced cooling ventilation
Origins	Product designed in the UK manufactured in Taiwan
Temperature Sensor PR0633	
Accuracy	+/- 0.5 °C
Resolution	0.0625 °C
Measurement Range	-30°C to +50°C (-22°F to +122°F)
The digital temperature sensor IC does not exhibit drift over time and is not dependant on battery terminal voltage.	
Temperature Sensor PR0636	
PT1000 Remote Sensor	PT1000, NTC2K, 470R, 700R, 3K, 5K, 6K, NTC2K25, NTC10K or NTC10K (2) Probe type is selected using the RDM Mobile App.
Temperature sensor cables should not be extended however if cable extension is unavoidable then it is advisable to use a 2k sensor type as it is less susceptible to resistance change over long cable lengths.	
Accuracy	+/- 0.5 °C
Resolution	0.1 °C
Measurement Range	-90°C to +128°C (-130°F to +262°F)
Bluetooth	
Bluetooth version	5.0
Operating Mode	BLE Mesh Network
Frequency	40 Channels pseudo-randomly selected from 2.4 – 2.485 GHz using AFH
Output Power	+4dBm to -20dBm
Range	Outdoors (Line of sight): 220m (722ft) – 330m (1082ft) Indoors: 10m (33ft) – 50m (164ft) Range dependant on site conditions. Obstacles such as metal structures and the presence of other 3 rd party wireless devices operating in the same frequency range affect the maximum range achievable.
Data rate	125Kbps to 2Mbit/s
Max Number Hops	5
Max Number Devices	64 per Bluetooth Access Point
Bluetooth ® is a registered trademark of Bluetooth SIG.	



Please ensure all power is switched off before installing or maintaining this product.

NFC	
Frequency	13.56 MHz
Signal Type	NFC-A Type 2 Tag conforming to ISO 14443-3A
Range	10mm (0.4in) – 30mm (1.2in) Range dependant on 3 rd party wireless device used to communicate to the NFC on the 4I module.
Data Rate	106 kbps

* The battery is not covered under the 5-year warranty. The battery lifespan would be around 1 year down at the lowest temperature.

Technical Specifications – PR0632-SF/RPT/DIN

Power Requirements	
Supply Voltage Range	5VDC \pm 10%
Supply Frequency	DC
Maximum Supply Current	1A
Typical Supply Current	< 0.5A
General	
Operating Temperature Range	0°C to +50°C (32°F to +122°F)
Operating Humidity	80% maximum
Storage Temperature Range	-20°C to +65°C (-4°F to +149°F)
Environmental	Indoor use at altitudes up to 2000m, pollution degree 2, installation category III.
Dimensions – L x W x H (SF/RPT)	193mm (7.6in) x 193mm (7.6in) x 23mm (0.9in)
Dimensions – L x W x H (DIN)	110mm (4.3in) x 52.5mm (2in) x 68mm (2.7in)
Approx. Mass (SF/RPT)	305g (0.672lbs)
Approx. Mass (DIN)	121g (0.267lbs)
IP Rating	IP20
EMC	EN 61326-1: 2013 EN 55032: 2015 ETSI 301 489-1 V2.2.3 ETSI 301 489-17 V3.1.1 FCC – X8WBT832 ICES-003 Issue 6
Ventilation	There is no requirement for forced cooling ventilation
Insulation	Class III
Origins	Product designed in the UK manufactured in Taiwan
Ethernet	
PoE Supply Voltage Range (SF/RPT only)	48VDC \pm 10% It's recommended that the product is powered by an IEEE 802.3af compliant power sourcing equipment (PSE).
PoE Supply Protection (SF/RPT only)	Short circuit protected
PoE standard (SF/RPT only)	Conforms to IEEE 802.3af Power-over-Ethernet (PoE) standard.
PoE Supply Frequency (SF/RPT only)	DC
PoE Maximum Supply Current (SF/RPT only)	1A
PoE Maximum Typical Current (SF/RPT only)	< 0.5A
Ethernet Interface	Conforms to 10Base-T & 100Base-T with Auto MDI/MDIX
Max Cable Length	100m
Bluetooth	
Bluetooth version	5.0
Operating Mode	BLE Mesh Network
Frequency	40 Channels pseudo-randomly selected from 2.4 – 2.485 GHz using AFH
Output Power	+4dBm to -20dBm
Range	Outdoors (Line of sight): 220m (722ft) – 330m (1082ft) Indoors: 10m (33ft) – 50m (164ft) Range dependant on site conditions. Obstacles such as metal structures



Please ensure all power is switched off before installing or maintaining this product.

	and the presence of other 3 rd party wireless devices operating in the same frequency range affect the maximum range achievable.	
Data rate	125Kbps to 2Mbit/s	
Max Number Hops	5 Hops	
Max Number Devices	64 per Bluetooth mesh unit	
NFC		
Frequency	13.56 MHz	
Signal Type	NFC-A Type 2 Tag conforming to ISO 14443-3A	
Range	10mm (0.4in) – 30mm (1.2in) Range dependant on 3 rd party wireless device used to communicate to the NFC on the gateway.	
Data Rate	106 kbps	
NFC		
Frequency	13.56 MHz	
Signal Type	NFC-A Type 2 Tag conforming to ISO 14443-3A	
Range	10mm (0.4in) – 30mm (1.2in) Range dependant on 3 rd party wireless device used to communicate to the NFC on the gateway.	
Data Rate	106 kbps	
RDM Bluetooth Mobile App		
Minimum Device Requirements:		
iOS	iPhone, iPad or iPod touch operating System must be iOS 13.1, device with NFC, iPhone 7 and above.	
Android	Operating System must be Android 10 (Q) SDK API 29, device with NFC	

Related Part Numbers

Description	Part Number
Bluetooth 232 Controller Communication Module	PR0630
Bluetooth Monitor (2I/2O)	PR0631-2I2O****
Bluetooth Monitor (4 Input)	PR0631-4I*
Bluetooth Ethernet Access Point with POE	PR0632-SF**
Bluetooth Ethernet Access Point (No PSU)	PR0632-SF-NOPSU
Bluetooth Ethernet Repeater	PR0632-SF-RPT**
Bluetooth Ethernet Repeater (No PSU)	PR0632-SF-RPT-NOPSU
Bluetooth Ethernet Access Point	PR0632-DIN*
Bluetooth Probe	PR0633
Bluetooth Temperature Probe (Overseas)	PR0633-OS***
Bluetooth Probe with External Sensor	PR0626
Bluetooth Probe with External Sensor (Overseas)	PR0626-OS
DMTouch Bluetooth Enabler (Block 32 devices)	PR0635
miniDM RDM Bluetooth Enabler (Block 32 devices)	PR0635-MD
PT1000 Air Probe (6m lead)	PR0170
PT1000 / 2K Combined Air Probe (6m lead)	PR0175
HVAC Duct Probe (NTC 10K Type 2)	PR0196-10K2
Outdoor Wall Mounted Temperature Sensor	PR0197-10K2
2K Air Probe (7m lead)	PR0240

*Supplied with 5v DIN rail mount PSU

**Supplied with 5vDC external desktop PSU

***No battery supplied with this device

****not available in USA.



Please ensure all power is switched off before installing or maintaining this product.

Battery Installation PR0633

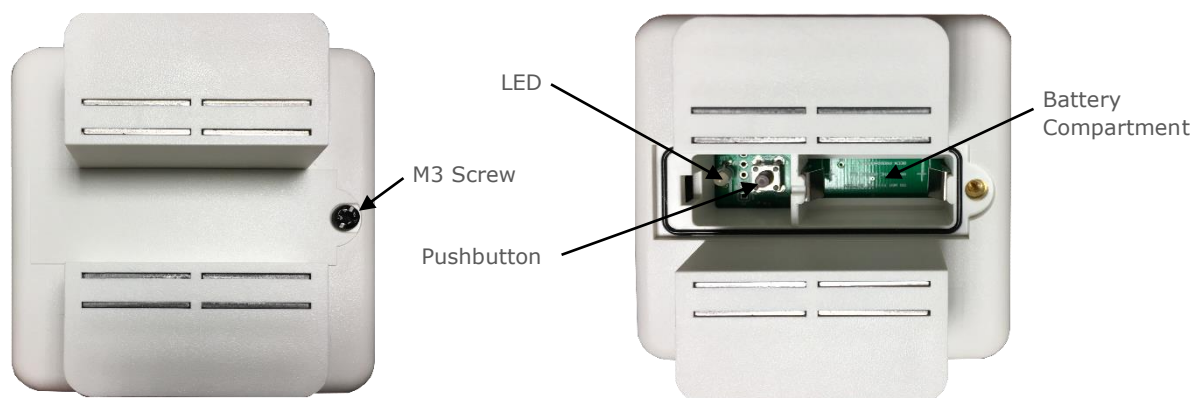

The PR0633 is supplied with a battery in the UK which needs to be fitted before using. The battery cover is secured by a single M3 screw, this should be removed using a suitable screwdriver. Once removed the setup pushbutton and LED are accessible along with the battery compartment.



The battery should be inserted as shown ensuring that the polarity is correct with the + terminal at the centre next to the pushbutton.

The cover should be replaced ensuring that the seal is still in place and the fixing screw replaced.



Please ensure all power is switched off before installing or maintaining this product.

Battery Installation PR0636



The PR0626 has a clip-on cover so no tools are required to insert or replace the batteries.

The cover can be removed by gently pulling the bottom of the cover sides away from the base as shown and then lifting upwards.

The battery compartment can now be accessed.



The batteries are held in place in the usual way with spring loaded terminals.

The spring-loaded terminal connects to the negative side of the battery as shown.



Cleaning

Clean the product by wiping with slightly dampened lint free cloth.



Please ensure all power is switched off before installing or maintaining this product.



Please ensure all power is switched off before installing or maintaining this product.

Mounting and Installation Instructions PR0633

The unit has magnetic feet which allow for quick and easy installation.

The installation instructions apply to both the Wireless Probe and the Bluetooth Access Point.

- When installing the Wireless Probe try to avoid physical obstacles which block direct line of sight with the Bluetooth Access Point such as brick walls, metal structures etc as this may reduce the effectiveness of the radio signal.
- The Bluetooth Access Point should be mounted centrally within the installation in relation to the majority of the Wireless Probes. Care must be taken to position the Access Point away from physical obstacles so that the Bluetooth Access Point can be detected by most Wireless Probes.
- As with all radio equipment avoid mounting the module nearby other electronic equipment as to minimise the possibility of interference.
- When mounting the module avoid metal surfaces, where possible, to maximise the radio signal range.
- Avoid mounting the Wireless Probe in between two metal surfaces.
- When mounting a Wireless Probe inside an enclosed metal object, transmission range is greatly reduced.

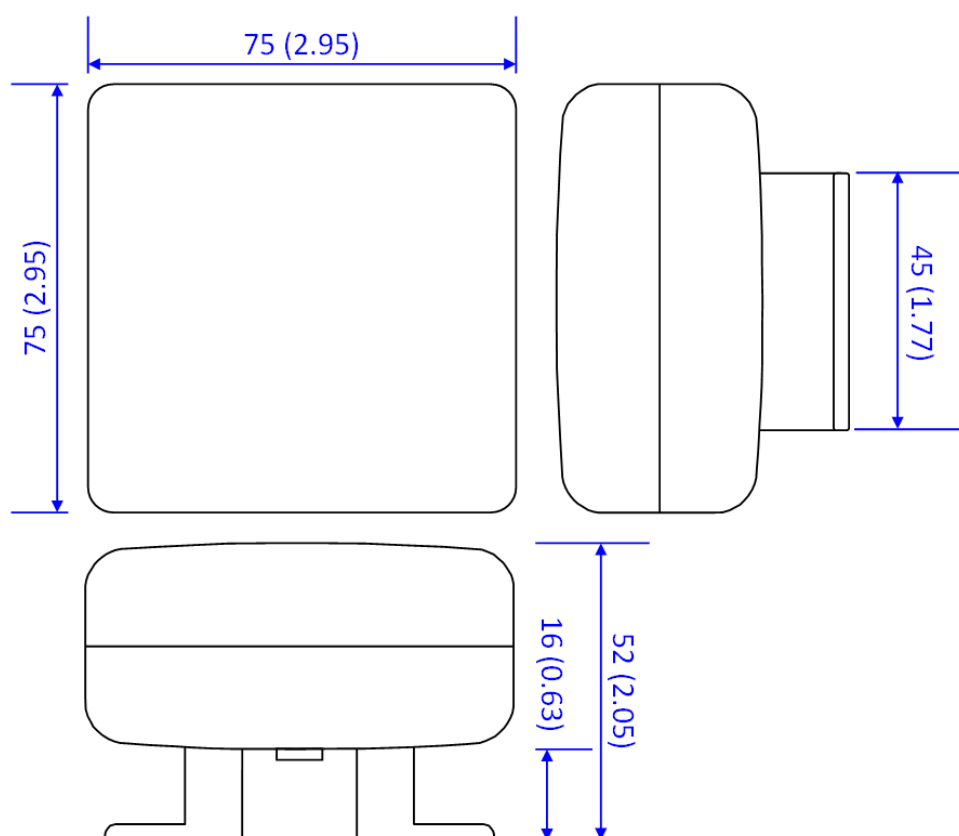

Please ensure all power is switched off before installing or maintaining this product.

Mounting and Installation Instructions PR0636

The unit has two mounting lugs 85mm (3.35in) apart as shown below.

The installation instructions apply to both the Wireless Probe and the Bluetooth Access Point.

- When installing the Wireless Probe try to avoid physical obstacles which block direct line of sight with the Bluetooth Access Point such as brick walls, metal structures etc as this may reduce the effectiveness of the radio signal.
- The Bluetooth Access Point should be mounted centrally within the installation in relation to the majority of the Wireless Probes. Care must be taken to position the Access Point away from physical obstacles so that the Bluetooth Access Point can be detected by most Wireless Probes.
- As with all radio equipment avoid mounting the module nearby other electronic equipment as to minimise the possibility of interference.
- When mounting the module avoid metal surfaces, where possible, to maximise the radio signal range.
- Avoid mounting the Wireless Probe in between two metal surfaces.
- When mounting a Wireless Probe inside an enclosed metal object, transmission range is greatly reduced.

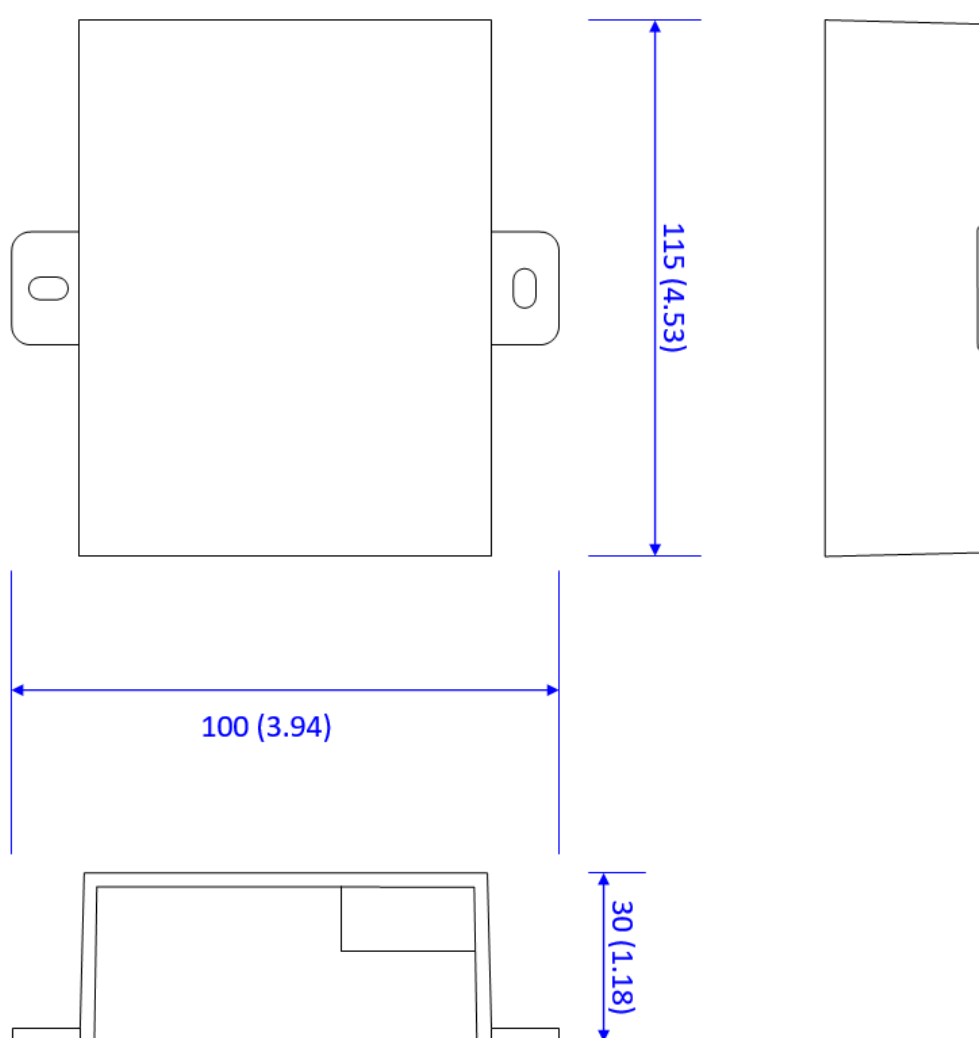

Please ensure all power is switched off before installing or maintaining this product.

Network Repeater

Since the Wireless Probe wakes up every 10 minutes to report the current temperature before returning to a low power sleep mode, communication issues can occur if the Wireless Probe doesn't have direct communication to the DMTouch/MiniDM. If communication issues are encountered setting the rotary switches on a Bluetooth Monitor (PR0631-4I or PR0631-2I2O) to '999' will enable the module to act as a repeater for the network traffic. The repeater module will not appear on the DMTouch/MiniDM as a device. These repeater modules can then be placed around the installation to provide a wireless network infrastructure.

Note: To ensure good coverage it is recommended to limit the number of modules to a maximum of 10 per repeater.

For further details on the 2I2O and 4I modules please refer to the appropriate user document.

PR0632-SF-RPT

The PR0632-RPT acts as a repeater device to boost the signal between other Bluetooth devices.

It is wall mountable and has the below connections:

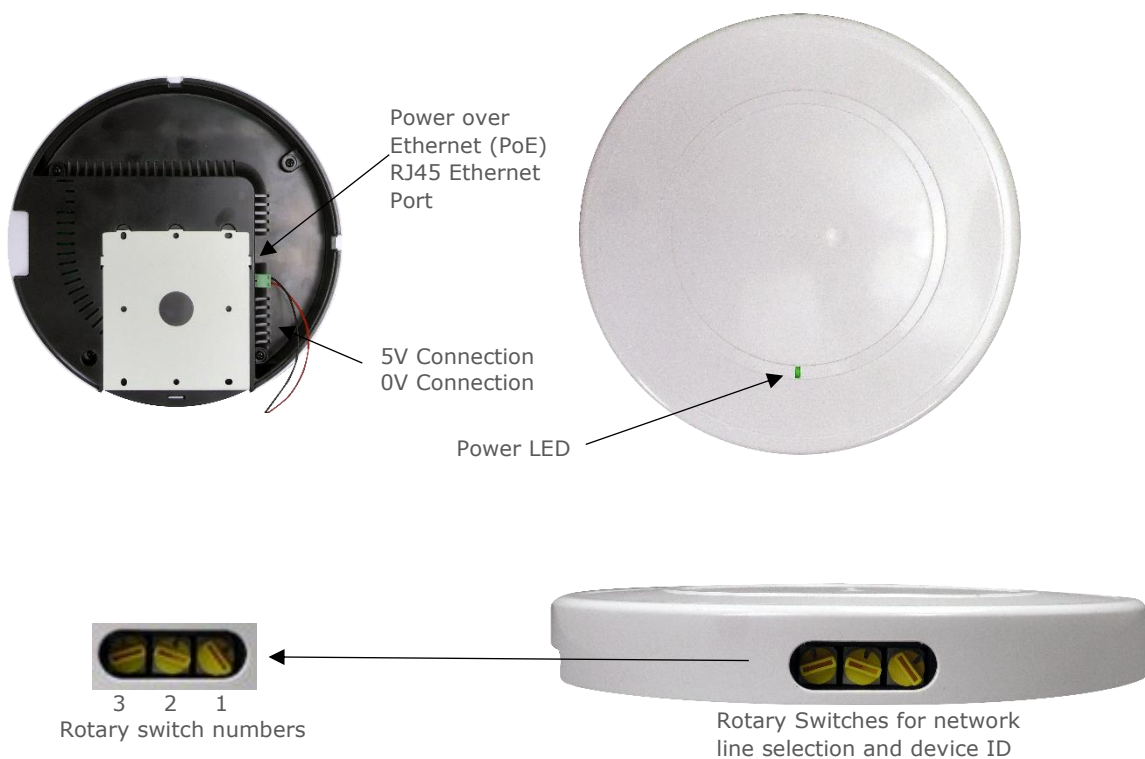

Rotary ID	Rotary Switch Operation
1	Switch number 1 sets the Bluetooth Network ID.
2	Sets the first digit of the Device ID as it would show when logged onto a DMTouch.
3	Sets the second digit of the Device ID as it would show when logged onto a DMTouch.
99*	If rotary switches 2 and 3 are both set to 9 then the repeater will be hidden and will not show on the Device List

For example, if rotary switch 2 is set for 5 and rotary switch 3 is set for 1 then the device would log onto the DMTouch as RC51-0. **Note:** This option is only available with DMTouch.

The PR0632-SF-RPT can be hidden from the Device List by setting rotary switches 2 and 3 to 9 along with rotary switch 1 set for the desired Network ID. If switches 2 and 3 are set to anything other than 9 then the PR0632-SF-RPT will be displayed on the Device List.

Note: If the PR0632-SF-RPT is set to show on the Device List then it will take up a network position on a PR0635. If it is set to be hidden from the Device List then it will not take up a network position.



Please ensure all power is switched off before installing or maintaining this product.

Disclaimer

The specifications of the product detailed in this document may change without notice. RDM Ltd shall not be liable for errors or omissions, for incidental or consequential damages, directly or indirectly, in connection with the furnishing, performance or misuse of this product or document.

Warranty Information

www.resourcedm.com/terms-and-conditions/

Revision History

Revision	Date	Changes
1.0	03/11/2020	First Release
1.0b	10/11/2020	Update to Technical Specification
1.0c	04/12/2020	Update to RDM App information
1.0d	09/12/2020	Android download link added
1.0e	10/12/2020	Android QR code added
1.1	18/12/2020	DM compatibility version added
1.1b	24/02/2021	APP information updated
1.1c	15/03/2021	Note added to advise 5v PSU supplied on PR00632
1.1d	02/04/2021	Note added regarding devices logging on over multiple access points
1.1e	28/09/2021	Data Builder section added.
1.1f	02/11/2021	Part numbers updated.
1.2	28/06/2023	PR0636 remote probe variant added.
1.2a	26/01/2024	Temperature range and battery information updated for PR0636



Please ensure all power is switched off before installing or maintaining this product.

Group Offices

RDM Group Head Office

80 Johnstone Avenue
Hillington Industrial Estate
Glasgow
G52 4NZ
United Kingdom

+44 (0)141 810 2828
support@resourcedm.com

RDM USA

9441 Science Center Drive
New Hope
Minneapolis
MN 55428
United States

+1 612 354 3923
usasupport@resourcedm.com

RDM Asia

Sky Park at One City
Jalan USJ 25/1
47650 Subang Jaya
Selangor
Malaysia

+60 3 5022 3188
asiatech@resourcedm.com



Visit www.resourcedm.com/support for more information on RDM solutions, additional product documentation and software downloads.

While every effort is made to ensure the information given within this document is accurate, Resource Data Management Ltd shall not be liable for errors or omissions, for incidental or consequential damages, directly or indirectly, in connection with the furnishing, performance or misuse of this product or document. All specifications are subject to change without notice.

See www.resourcedm.com for terms and conditions of sales.

Copyright © Resource Data Management