



**Mercury**  
**PR0710-PLS**



**Intuitive**  
**PR0750-PLS**

# Mercury 2 & Intuitive Mercury Pulse Reader Installation & User Guide

## Resource Data Management

### UK OFFICE

Resource Data Management Ltd  
80 Johnstone Avenue,  
Hillington Industrial Estate,  
Glasgow, Scotland, G52 4NZ, UK  
☎ +44(0)141 810 2828  
✉ sales@resourcedm.com

### US OFFICE

Resource Data Management Inc  
100 North Sixth Street,  
Suite 630B,  
Minneapolis, MN 55403, USA  
☎ Tel +1 612 354 2923  
✉ usasales@resourcedm.com

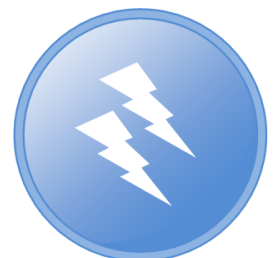

**Table of Contents:**

**THE MERCURY 2 & INTUITIVE MERCURY PULSE READER..... 3**

**Description ..... 3**

    Variants ..... 3

**Configuration ..... 3**

**Compatible Network Interfaces ..... 3**

**Front Display Features ..... 4**

**Connections ..... 4**

    Mercury Mk2 ..... 4

    Intuitive Mercury Controller ..... 5

    Intuitive Mercury Network Expansion Options ..... 5

**Input and Output Allocation Tables ..... 5**

    Input / Output allocation table ..... 5

**Setting up the controller ..... 6**

    Setup through front buttons ..... 6

    Setup Function Menu ..... 6

**Recommended set-up method ..... 6**

    rtc. Real time clock (This will automatically synchronise on network systems) ..... 6

    PArA. Set/view parameters (This can be achieved at the network front end) ..... 6

**Parameter Table ..... 7**

**Parameter Description ..... 9**

**Network Configuration ..... 10**

    RS485 Legacy module / Intuitive Internal RS485 Network card ..... 10

    Fast Network Address Reset ..... 10

    Wireless Mesh Module / Intuitive Wireless Mesh Network Card ..... 10

    IP Futura module / Intuitive Internal IP Network card ..... 11

**CLr - Clear Channels ..... 12**

**Alarm Messages ..... 12**

**Network Alarms ..... 12**

**Operation ..... 12**

    Input / Output Table ..... 12

    Specifications ..... 13

    Power requirements ..... 13

    General ..... 13

    Relay Specification ..... 13

    Inputs ..... 14

    Reader Specification ..... 14

**Installation ..... 14**

    Panel Cut-out and Clearances ..... 14

    Fixing ..... 14

**Dimensions ..... 14**

    Mercury Mk2 ..... 14

    Intuitive Mercury controller ..... 15

    Intuitive Mercury Mounting Instructions ..... 15

    Cleaning ..... 15

**Disclaimer ..... 15**

**REVISION HISTORY ..... 16**



Ensure that all power is switched off before installing or maintaining this product

## The Mercury 2 & Intuitive Mercury Pulse Reader

### From Resource Data Management

#### Description

The Mercury Pulse Reader has 6 independent inputs that can be configured for pulse counting from the pulse relay of most utility meters. The input is activated by the use of a 0 volt return through the normally open and common contacts of the relay inside the utility meter.

In addition to the 6 inputs, the 5 on board relays can be used remotely by "The Data Builder".

The Pulse Reader will accumulate pulses on a per channel basis to give a running total. It also has 3 time slots (cans) on a per channel basis that counts the number of pulses during the time interval. These "can" times are globally configurable for: -

- 5 minute
- 15 minute
- 30 minute
- 1 hour
- 12 hour
- 24 hour

A scaling parameter is available that ensures compatibility with the majority of utility meter scale factors. The Pulse Reader is unit-less, item aliasing can be used on the Data Manager to indicate units.

There is also a DIN rail mounted range, known as the Intuitive Mercury range, which is designed to be used in a control panel or electrical tray. This range has the same features as the Mercury Mk2 controller with additional benefits such as higher rated relays each protected by an integral fuse and fuse protection for the incoming power supply, all connections are plug and socket. There are multiple network interfaces to choose from including Ethernet.

#### Variants

Description	Part Number
Mercury Mk2, 6 Channel Pulse Reader	PR0710-PLS
Intuitive Mercury, 6 Channel Pulse Reader	PR0750-PLS

#### Configuration

The pulse reader is shipped pre-configured with all 6 channels "off".

#### Compatible Network Interfaces

Mercury and Intuitive Mercury controllers are capable of connecting to either a TCP/IP local area network, an RS485 Genus compatible network, or they can be used in standalone mode with no network output. To connect to a network you must add the correct communications module. Connecting to any of these communication modules will automatically be detected on power up and will affect the set up screens available to you.

Description	Part Number
IP Futura (Single Mercury to IP Interface)	PR0016
RS485 Interface (Single Mercury to RS485 Interface)	PR0026
Mercury IP Switch (IP support for 10 controllers)	PR0018
Mercury IP Switch with Pressure/Humidity Inputs	PR0018-PHI
Wireless Mesh Interface (for single Mercury)	PR0730

The Intuitive Mercury Controller is supplied as standard with an internal RS232 network card, this allows connection to any of the above external network interfaces. Three alternative internal network cards are also available, these can be supplied factory fitted as an option or purchased separately as an interface kit.

Description	Part Number
Intuitive Internal IP Network Card Interface Kit	PR0770
Intuitive Internal RS485 Network Card Interface Kit	PR0771
Intuitive Internal Wireless Mesh Network Card Interface	PR0772



Ensure that all power is switched off before installing or maintaining this product

## Front Display Features

LED's: -

Valve (Not Used)

Fans (Not Used)

Lights (Not Used)

Defrost (Not used)

On-Line

- Off No network attached
- Flashing Attempting to Log on to network
- Steady On-line

Service (Not Used)

Alarm

- Off No current alarms
- On Current alarm(s)

HACCP (Not Used)



## Keys

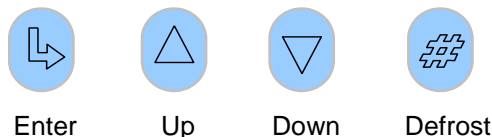

**Note:** Function keys illuminate when pressed, illumination is turned off 20 seconds after the key is used. Press and hold the defrost button to force a manual defrost



## Main Display

4 character LED display, used to display time and status messages.

**Note** the Intuitive Mercury display is Green in colour when lit.

## Connections

### Mercury Mk2

Input and Output connections are made to the back of the controller, the RS232 communication port is on the side. The diagram shows the connection detail. Inputs and outputs are assigned according to the chosen configuration. See [Input/Output](#) tables for further details on connections.

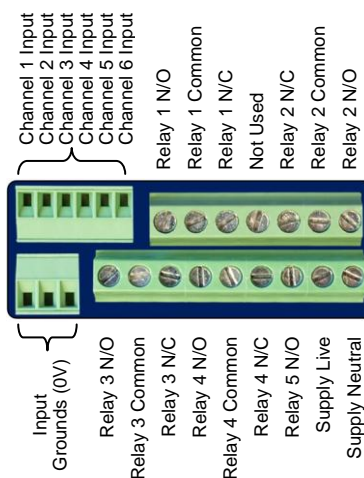

Do not connect an earth.

Ensure that all power is switched off before installing or maintaining this product

## Intuitive Mercury Controller

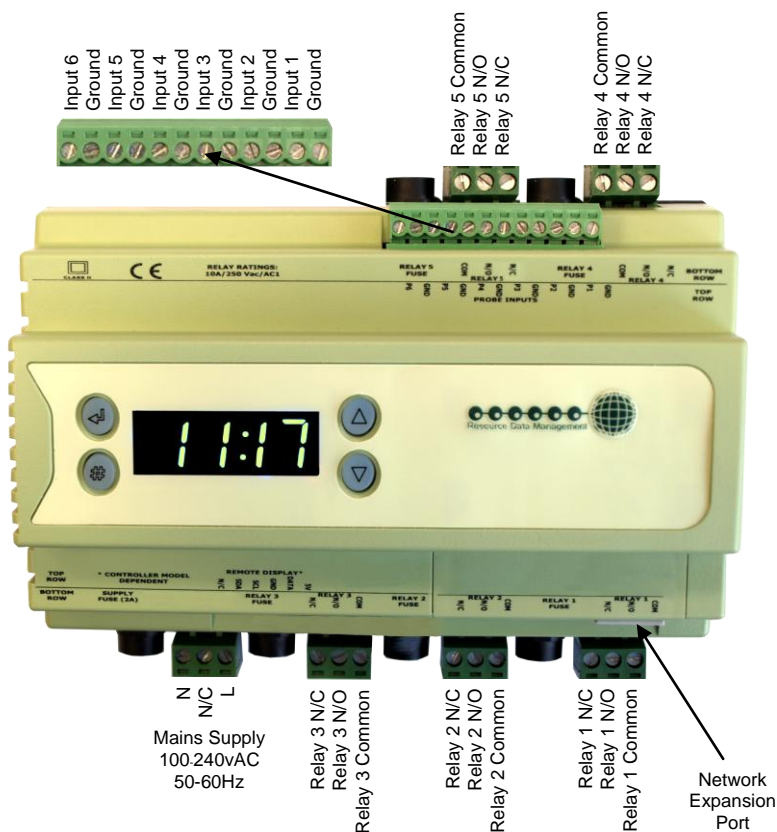

All inputs and outputs are plug and socket. The supply voltage and relay outputs have individual fuse protection.



**Do not connect an earth.**

## Input and Output Allocation Tables

The following tables indicate; on a controller type basis, the functions of the inputs and outputs. Also shown are the defrost inputs that are derived by switching in a fixed value resistor across the input.

### Input / Output allocation table

Pulse Reader	Description	Alarm Action
Input 1	Channel 1 ( 0 volt return)	Yes
Input 2	Channel 2 ( 0 volt return)	Yes
Input 3	Channel 3 ( 0 volt return)	Yes
Input 4	Channel 4 ( 0 volt return)	Yes
Input 5	Channel 5 ( 0 volt return)	Yes
Input 6	Channel 6 ( 0 volt return)	Yes
Relay 1	Remote Relay 1	N/A
Relay 2	Remote Relay 2	N/A
Relay 3	Remote Relay 3	N/A
Relay 4	Remote Relay 4	N/A
Relay 5	Remote Relay 5	N/A

### Note:

Relay 1 to 4: (Software) Outputs shows Off = Relay Energised

Relay 5 : (Software) Outputs shows Off = Relay De-Energised.

## Intuitive Mercury Network Expansion Options

### RS232 Network Card (Default)

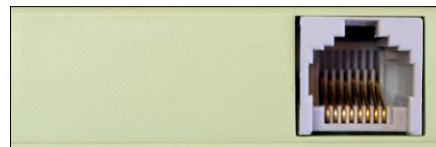

The Intuitive Mercury is supplied with an RS232 Network Card fitted as standard. Some example optional network cards are shown below

### IP Network Card (PR0770)

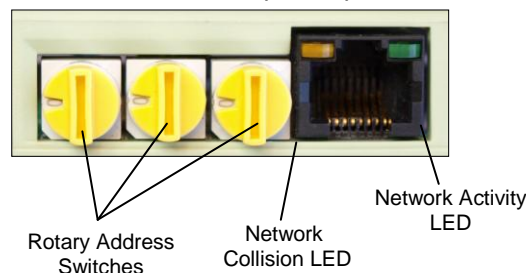

### RS485 Network Card (PR0771)

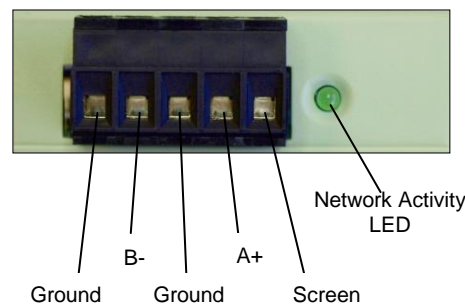

### Wireless Mesh Card (PR0772)

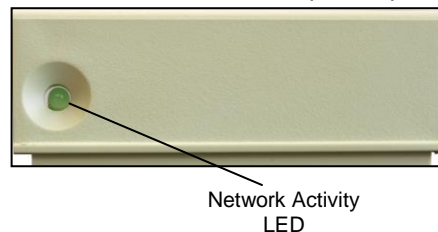

Ensure that all power is switched off before installing or maintaining this product

## Setting up the controller

Access to the controller can be achieved several ways

- Through the front mounted buttons
- Direct access by PC or palm top into the rear comms port. This requires a software package available on the RDM website
- Through legacy front end panels on 485 networks
- Through the RDM Data Manager.
- Across an IP network. (Current controller IP address required)

### Setup through front buttons



To enter setup mode, hold the Enter and Down buttons together for approximately 3 seconds until the message "Ent" appears on the display. Now press the Enter button again to enter the function menu. IO will be displayed. Scroll up or down to go through the list.

### Setup Function Menu

Display	Option	Explained in Paragraph
IO	View Inputs / Outputs and States	<a href="#">Input / output table</a>
PArA	Set/View Parameters	<a href="#">Set view parameters</a>
Rtc	Set/view Clock (rtc = Real Time Clock)	<a href="#">Real Time Clock</a>
nEt	Set/view network configuration	<a href="#">Network Configuration</a>
SoFt	View software version	
Clr	Clear Channels	<a href="#">Clear Channels</a>
ESC	Exit Setup mode	

### Recommended set-up method

If you are not connecting to a network and want to set up the controller through the buttons we recommend you use the following order from the function menu.

#### rtc. Real time clock (This will automatically synchronise on network systems)

- Use the up or down buttons to scroll through the display until the display reads "rtc"
- Press enter. The display will show "t-1". press enter again
- Scroll hours up or down (0 – 23) press enter
- Use up button to select "t-2", press enter
- Scroll minutes up or down (0 – 59) press enter
- Repeat for t-3 (seconds 0 – 59)
- Repeat for t -4 (Days up to 31)
- Repeat for t -5 (months up to 12)
- Repeat for t -6 (Year up to 99)
- Use up button to display "ESC", press enter to display "rtc"

Time clock is now set

#### PArA. Set/view parameters (This can be achieved at the network front end)

- From the function menu scroll to select PArA
- Pressing Enter while PArA is displayed will enter the parameter menu. The first parameter option will be displayed as P-01. Pressing the Up or Down button will present the other parameter options P-02, P-03 etc. See the parameter list below to find what parameter number corresponds to which actual parameter. Pressing the Enter button will show the current value of the selected parameter. Press Up or Down to modify the value and press Enter again to save the value. The parameter list number will be displayed again. Two other options are present in the parameter menu – dFLt and ESC. Selecting ESC will exit setup mode. Selecting dFLt will reset all parameters back to the default values for the current type of controller.



Ensure that all power is switched off before installing or maintaining this product

## Parameter Table

Number	Parameter	Range	Step	Value
P-01	Channel 1 set	0 - 6	1	0: off (default) 1: 1 pulse = 100 Units 2: 1 pulse = 10 Units 3: 1 pulse = 1 Unit 4: 1 pulse = 0.1 Unit 5: 1 pulse = 0.01 Unit 6: 1 pulse = 0.001 Unit
P-02	Ch 1 Can A (x1000 Counter) alarm level	0 - 9999	1	0 (default)
P-03	Ch 1 Can A (Units Counter) alarm level	0 - 999.9	0.1	0.0 (default)
P-04	Ch 1 Can B (x1000 Counter) alarm level	0 - 9999	1	0 (default)
P-05	Ch 1 Can B (Units Counter) alarm level	0 - 999.9	0.1	0.0 (default)
P-06	Ch 1 Can C (x1000 Counter) alarm level	0 - 9999	1	0 (default)
P-07	Ch 1 Can C (Units Counter) alarm level	0 - 999.9	0.1	0.0 (default)
P-08	Ch 1 Scale Factor	0 - 99.9	0.1	1.0
P-11	Channel 2 set	0 - 6	1	0: off (default) 1: 1 pulse = 100 Units 2: 1 pulse = 10 Units 3: 1 pulse = 1 Unit 4: 1 pulse = 0.1 Unit 5: 1 pulse = 0.01 Unit 6: 1 pulse = 0.001 Unit
P-12	Ch 2 Can A (x1000 Counter) alarm level	0 - 9999	1	0 (default)
P-13	Ch 2 Can A (Units Counter) alarm level	0 - 999.9	0.1	0.0 (default)
P-14	Ch 2 Can B (x1000 Counter) alarm level	0 - 9999	1	0 (default)
P-15	Ch 2 Can B (Units Counter) alarm level	0 - 999.9	0.1	0.0 (default)
P-16	Ch 2 Can C (x1000 Counter) alarm level	0 - 9999	1	0 (default)
P-17	Ch 2 Can C (Units Counter) alarm level	0 - 999.9	0.1	0.0 (default)
P-18	Ch 2 Scale Factor	0 - 99.9	0.1	1.0
P-21	Channel 3 set	0 - 6	1	0: off (default) 1: 1 pulse = 100 Units 2: 1 pulse = 10 Units 3: 1 pulse = 1 Unit 4: 1 pulse = 0.1 Unit 5: 1 pulse = 0.01 Unit 6: 1 pulse = 0.001 Unit
P-22	Ch 3 Can A (x1000 Counter) alarm level	0 - 9999	1	0 (default)
P-23	Ch 3 Can A (Units Counter) alarm level	0 - 999.9	0.1	0.0 (default)
P-24	Ch 3 Can B (x1000 Counter) alarm level	0 - 9999	1	0 (default)
P-25	Ch 3 Can B (Units Counter) alarm level	0 - 999.9	0.1	0.0 (default)
P-26	Ch 3 Can C (x1000 Counter) alarm level	0 - 9999	1	0 (default)
P-27	Ch 3 Can C (Units Counter) alarm level	0 - 999.9	0.1	0.0 (default)
P-28	Ch 3 Scale Factor	0 - 99.9	0.1	1.0
P-31	Channel 4 set	0 - 6	1	0: off (default) 1: 1 pulse = 100 Units 2: 1 pulse = 10 Units 3: 1 pulse = 1 Unit 4: 1 pulse = 0.1 Unit 5: 1 pulse = 0.01 Unit 6: 1 pulse = 0.001 Unit
P-32	Ch 4 Can A (x1000 Counter) alarm level	0 - 9999	1	0 (default)
P-33	Ch 4 Can A (Units Counter) alarm level	0 - 999.9	0.1	0.0 (default)
P-34	Ch 4 Can B (x1000 Counter) alarm level	0 - 9999	1	0 (default)
P-35	Ch 4 Can B (Units Counter) alarm level	0 - 999.9	0.1	0.0 (default)
P-36	Ch 4 Can C (x1000 Counter) alarm level	0 - 9999	1	0 (default)
P-37	Ch 4 Can C (Units Counter) alarm level	0 - 999.9	0.1	0.0 (default)
P-38	Ch 4 Scale Factor	0 - 99.9	0.1	1.0
P-41	Channel 5 set	0 - 6	1	0: off (default) 1: 1 pulse = 100 Units 2: 1 pulse = 10 Units 3: 1 pulse = 1 Unit 4: 1 pulse = 0.1 Unit



Ensure that all power is switched off before installing or maintaining this product

				5: 1 pulse = 0.01 Unit 6: 1 pulse = 0.001 Unit
P-42	Ch 5 Can A (x1000 Counter) alarm level	0 - 9999	1	0 (default)
P-43	Ch 5 Can A (Units Counter) alarm level	0 - 999.9	0.1	0.0 (default)
P-44	Ch 5 Can B (x1000 Counter) alarm level	0 - 9999	1	0 (default)
P-45	Ch 5 Can B (Units Counter) alarm level	0 - 999.9	0.1	0.0 (default)
P-46	Ch 5 Can C (x1000 Counter) alarm level	0 - 9999	1	0 (default)
P-47	Ch 5 Can C (Units Counter) alarm level	0 - 999.9	0.1	0.0 (default)
P-48	Ch 5 Scale Factor	0 - 99.9	0.1	1.0
P-51	Channel 6 set	0 - 6	1	0: off (default) 1: 1 pulse = 100 Units 2: 1 pulse = 10 Units 3: 1 pulse = 1 Unit 4: 1 pulse = 0.1 Unit 5: 1 pulse = 0.01 Unit 6: 1 pulse = 0.001 Unit
P-52	Ch 6 Can A (x1000 Counter) alarm level	0 - 9999	1	0 (default)
P-53	Ch 6 Can A (Units Counter) alarm level	0 - 999.9	0.1	0.0 (default)
P-54	Ch 6 Can B (x1000 Counter) alarm level	0 - 9999	1	0 (default)
P-55	Ch 6 Can B (Units Counter) alarm level	0 - 999.9	0.1	0.0 (default)
P-56	Ch 6 Can C (x1000 Counter) alarm level	0 - 9999	1	0 (default)
P-57	Ch 6 Can C (Units Counter) alarm level	0 - 999.9	0.1	0.0 (default)
P-58	Ch 6 Scale Factor	0 - 99.9	0.1	1.0
P-61	Can A size (Global)	0 = 5 min 1 = 15 min 2 = 30 min 3 = 1 hour 4 = 12 hours 5 = 24 hours	1	1 hour
P-62	Can B size (Global)	0 = 5 min 1 = 15 min 2 = 30 min 3 = 1 hour 4 = 12 hours 5 = 24 hours	1	12 hours
P-63	Can C size (Global)	0 = 5 min 1 = 15 min 2 = 30 min 3 = 1 hour 4 = 12 hours 5 = 24 hours	1	24 hours



Ensure that all power is switched off before installing or maintaining this product

## Parameter Description

Number	Parameter	Range	Description
P-*1	Channel 1 set	0 - 6	0: off (default) 1: 1 pulse = 100 Units 2: 1 pulse = 10 Units 3: 1 pulse = 1 Unit 4: 1 pulse = 0.1 Unit 5: 1 pulse = 0.01 Unit 6: 1 pulse = 0.001 Unit
P-*2	Ch 1 Can A (x1000 Counter) alarm level	0 - 9999	Can A will alarm when the value of P-*2 + P-*3 is reached
P-*3	Ch 1 Can A (Units Counter) alarm level	0 - 999.9	
P-*4	Ch 1 Can B (x1000 Counter) alarm level	0 - 9999	Can B will alarm when the value of P-*4 + P-*5 is reached
P-*5	Ch 1 Can B (Units Counter) alarm level	0 - 999.9	
P-*6	Ch 1 Can C (x1000 Counter) alarm level	0 - 9999	Can B will alarm when the value of P-*6 + P-*7 is reached
P-*7	Ch 1 Can C (Units Counter) alarm level	0 - 999.9	
P-*8	Ch 1 Scale Factor	0 – 99.9	Use in conjunction with P-*1 to achieve the desired scaling factor. It is simply division factor.  Example: With P-01 set to '3' (1 pulse = 1 unit) and P-08 set to 4.0 Then 4 pulses will equate to 1 unit.
P-61	Can A size (Global)	0 = 5 min 1 = 15 min 2 = 30 min 3 = 1 hour 4 = 12 hours 5 = 24 hours	This is the time interval for Can A to capture counts. When set, Can A will show the count within the stated time period.  For example if set to 1 Hour, Can A will show the counts that occurred in the last hour.  <b>Note:</b> this is a global value and sets all 6 channels.
P-62	Can B size (Global)	0 = 5 min 1 = 15 min 2 = 30 min 3 = 1 hour 4 = 12 hours 5 = 24 hours	This is the time interval for Can B to capture counts. When set, Can B will show the count within the stated time period.  For example if set to 1 Hour, Can B will show the counts that occurred in the last hour.  <b>Note:</b> this is a global value and sets all 6 channels.
P-63	Can C size (Global)	0 = 5 min 1 = 15 min 2 = 30 min 3 = 1 hour 4 = 12 hours 5 = 24 hours	This is the time interval for Can C to capture counts. When set, Can C will show the count within the stated time period.  For example if set to 1 Hour, Can C will show the counts that occurred in the last hour.  <b>Note:</b> this is a global value and sets all 6 channels.

**Note:** Parameters and Values are split into two components; x1 units and x1000 units. E.g. 6300 would be represented by; x1000 showing '6' and x1 showing '300'.



Ensure that all power is switched off before installing or maintaining this product

## Network Configuration

The final section to setup is the network address. In all instances, this must be done before the controller is connected to the site network.

When logging a Mercury or an Intuitive Mercury with an RS232 interface onto a network you must first connect the controller to a communications module, this is either a 485 Legacy, IP Futura, Mercury Switch or wireless Mesh interface. When using an Intuitive Mercury controller, the controller has to have the correct network card fitted (see [Compatible network interfaces](#)). For connection to a Mercury Switch (Hub) or an external network interface, the standard fitment RS232 network card is utilised.

### RS485 Legacy module / Intuitive Internal RS485 Network card

Using RS485, the controllers have an auto-initialise function, which will automatically log the device onto the site network. If the wrong address has been entered onto the network, you will have to reset the controller address by setting the address to 00-0, and then re-enter the correct address (you may have to deregister the wrong address from the home system as well).

Connecting an RS485 legacy Module or an Intuitive Internal RS485 network card to the controller will govern which set up screens are made available in the 'Net' menu. Both modules support the "Genus" protocol only. Using RS485 will show the below;

Display	Option
485t	485 Network Type
485A	485 Address/Name
gAdd	Show underlying network address assigned to controller
rLog	Re-log the controller back onto the network
CLrA	Clear the address/name from the controller
ESC	Exit network menu. <b>N.B.</b> this option <b>must</b> be selected to save any changes made in this menu

The **485t** option shows a value representing the network type. The possible values are;

Value	Network Type
1	Genus compatible (all versions)
2	Wireless Mesh

Ensure option '1' is selected.

The **485A** option shows a value representing the name of the controller in a Genus compatible network. For example, if the value shown in 485A is shown as "05-6". The controller would try to log onto a Genus compatible network using the name 'RC05-6'.

The **gAdd** option displays (in hexadecimal format) the underlying network address assigned to the controller when it was logged onto the network. NB this is automatically assigned by the Data Manager.

The **rLog** option allows the controller to be logged back onto the network with its current name. The 'rLog' message will flash, waiting for confirmation. To confirm, press the Enter button to execute the command, Up or Down buttons to cancel.

The **CLrA** option will clear out the network address and name in the controller. The 'ClrA' message will flash for confirmation. Press the Enter button to execute the command, Up or Down buttons to cancel.

### Fast Network Address Reset

To enter this mode, hold the Enter, Up and Down buttons together for approximately 3 seconds until the message CLrA appears on the display. CLrA is the first option in the menu consisting of the following options:

Display	Option
CLrA	Clear the address/name from the controller
ESC	Exit Setup mode

Pressing the Enter button to select the CLrA option will cause the 'CLrA' message to flash for confirmation, if the network type is set to Genus compatible. Press the Enter button to execute the command, Up or Down buttons to cancel. If the network type is not set to Genus compatible then the ClrA message will not flash and the ESC option can be used to exit the menu.

### Wireless Mesh Module / Intuitive Wireless Mesh Network Card

When a wireless mesh module or an Intuitive Wireless mesh daughter card is connected to the controller the 'Net' menu will show similar options to that off the 'RS485' network. The only difference to the settings would be that the 485t should be set for '2'. Then the same steps should be taken to that of the RS485 option to log the unit on to the wireless mesh. Note, the wireless mesh network should already be set up on the data manager. Please see the Data Manager documentation for setup instructions. Furthermore, please see documentation on the PR0730 Wireless Mesh Network Module for setup instructions.



Ensure that all power is switched off before installing or maintaining this product

## IP Futura module / Intuitive Internal IP Network card

In an IP system there are two options;

- IP-L
- IP-r

IP-L allows you to fix an IP address into the controller, which you would use when you are connecting the controllers onto a customer's local area network. This would allow the customer to view each controller using a generic Internet browser.

IP-r allows you to give each controller on the system a unique number (using the rotary switches). This number is then allocated a dynamic IP address by the system's DHCP server (such as the RDM Data Manager).

### IP-L

To configure the communication module or network card for IP-L, set all three rotary switches to zero. The module should then be connected to the controller. In the case of an Intuitive Mercury controller where the network card is already fitted, the controller should be powered off, all three rotary switches set to zero and the controller powered on.

- From the function menu you can now select 'nEt'.
- Press enter and the display will show "IP-L", press enter once more.
- You can now set the IP network settings by using the table below

Display	Option
IP-1	IP Address byte 1
IP-2	IP Address byte 2
IP-3	IP Address byte 3
IP-4	IP Address byte 4
nL	Network Mask Length (see below table)
gt-1	Gateway Address byte 1
gt-2	Gateway Address byte 2
gt-3	Gateway Address byte 3
gt-4	Gateway Address byte 4
ESC	Exit network menu. <b>N.B.</b> this option <b>must</b> be selected to save any changes made in this menu

### IP-r

To configure the communication module for IP-r, set the three rotary switches to give each controller a unique identifier. The module should then be connected to the controller and the network. In the case of an Intuitive Mercury controller where the network card is already fitted, the three rotary switches must be set when the controller is powered off. The controller should then be powered on to connect to the network.

- From the function menu you can now select 'nEt'
- Press enter and the display will show "IP-r", press enter once more.
- You can now view (only) the address given by the DHCP server

To ease setup, a single network mask length value is used. If the address has been specified with a network mask value in dotted IP format e.g. 255.255.255.0 then the table below gives the conversion:

Mask	Length	Mask	Length	Mask	Length
		255.255.254.0	23	255.254.0.0	15
255.255.255.252	30	255.255.252.0	22	255.252.0.0	14
255.255.255.248	29	255.255.248.0	21	255.248.0.0	13
255.255.255.240	28	255.255.240.0	20	255.240.0.0	12
255.255.255.224	27	255.255.224.0	19	255.224.0.0	11
255.255.255.192	26	255.255.192.0	18	255.192.0.0	10
255.255.255.128	25	255.255.128.0	17	255.128.0.0	09
255.255.255.0	24	255.255.0.0	16	255.0.0.0	08



Ensure that all power is switched off before installing or maintaining this product

## CLr - Clear Channels

Channels can be reset to zero by using the clear channel option. Press enter at the "Clr" screen, then select Clr-1 through to Clr-6, then press enter to clear the channel.

## Alarm Messages

Alarms are indicated by the red LED only, no screen messages are displayed.

## Network Alarms

The table below shows the text and associated type number that is sent to the system "front end". The type number is normally used to provide different alarm actions.

Alarm text	Type # (index)
Channel 1 Can A Count	21
Channel 1 Can B Count	22
Channel 1 Can C Count	23
Channel 2 Can A Count	21
Channel 2 Can B Count	22
Channel 2 Can C Count	23
Channel 3 Can A Count	21
Channel 3 Can B Count	22
Channel 3 Can C Count	23

Alarm text	Type # (index)
Channel 4 Can A Count	21
Channel 4 Can B Count	22
Channel 4 Can C Count	23
Channel 5 Can A Count	21
Channel 5 Can B Count	22
Channel 5 Can C Count	23
Channel 6 Can A Count	21
Channel 6 Can B Count	22
Channel 6 Can C Count	23

## Operation

Connect a 0v line from the reader through the utility meters volt free pulse relay back to the desired input. Set the channel parameters to correspond with the meters pulse information. The reader will accumulate the pulse information from the meter. The pulse will be displayed as a single value. Please see the [Reader Specification](#) for pulse times.

## Input / Output Table

Number	IO	Range	Step
I-01	Chan 1 x 1000	0 - 9999	1
I-02	Chan 1 x 1	0 - 999.9	0.1
I-03	Chan 2 x 1000	0 - 9999	1
I-04	Chan 2 x 1	0 - 999.9	0.1
I-05	Chan 3 x 1000	0 - 9999	1
I-06	Chan 3 x 1	0 - 999.9	0.1
I-07	Chan 4 x 1000	0 - 9999	1
I-08	Chan 4 x 1	0 - 999.9	0.1
I-09	Chan 5 x 1000	0 - 9999	1
I-10	Chan 5 x 1	0 - 999.9	0.1
I-11	Chan 6 x 1000	0 - 9999	1
I-12	Chan 6 x 1	0 - 999.9	0.1
I-21	Ch 1 CanA x 1000	0 - 9999	1
I-22	Ch 1 CanA x 1	0 - 999.9	0.1
I-23	Ch 1 CanB x 1000	0 - 9999	1
I-24	Ch 1 CanB x 1	0 - 999.9	0.1
I-25	Ch 1 CanC x 1000	0 - 9999	1
I-26	Ch 1 CanC x 1	0 - 999.9	0.1
I-31	Ch 2 CanA x 1000	0 - 9999	1
I-32	Ch 2 CanA x 1	0 - 999.9	0.1
I-33	Ch 2 CanB x 1000	0 - 9999	1
I-34	Ch 2 CanB x 1	0 - 999.9	0.1
I-35	Ch 2 CanC x 1000	0 - 9999	1
I-36	Ch 2 CanC x 1	0 - 999.9	0.1
I-41	Ch 3 CanA x 1000	0 - 9999	1
I-42	Ch 3 CanA x 1	0 - 999.9	0.1

Number	IO	Range	Step
I-43	Ch 3 CanB x 1000	0 - 9999	1
I-44	Ch 3 CanB x 1	0 - 999.9	0.1
I-45	Ch 3 CanC x 1000	0 - 9999	1
I-46	Ch 3 CanC x 1	0 - 999.9	0.1
I-51	Ch 4 CanA x 1000	0 - 9999	1
I-52	Ch 4 CanA x 1	0 - 999.9	0.1
I-53	Ch 4 CanB x 1000	0 - 9999	1
I-54	Ch 4 CanB x 1	0 - 999.9	0.1
I-55	Ch 4 CanC x 1000	0 - 9999	1
I-56	Ch 4 CanC x 1	0 - 999.9	0.1
I-61	Ch 5 CanA x 1000	0 - 9999	1
I-62	Ch 5 CanA x 1	0 - 999.9	0.1
I-63	Ch 5 CanB x 1000	0 - 9999	1
I-64	Ch 5 CanB x 1	0 - 999.9	0.1
I-65	Ch 5 CanC x 1000	0 - 9999	1
I-66	Ch 5 CanC x 1	0 - 999.9	0.1
I-71	Ch 6 CanA x 1000	0 - 9999	1
I-72	Ch 6 CanA x 1	0 - 999.9	0.1
I-73	Ch 6 CanB x 1000	0 - 9999	1
I-74	Ch 6 CanB x 1	0 - 999.9	0.1
I-75	Ch 6 CanC x 1000	0 - 9999	1
I-76	Ch 6 CanC x 1	0 - 999.9	0.1
O-21	Remote Relay 1	0 (Off), 1 (On)	1
O-22	Remote Relay 2	0 (Off), 1 (On)	0.1
O-23	Remote Relay 3	0 (Off), 1 (On)	1
O-24	Remote Relay 4	0 (Off), 1 (On)	0.1
O-25	Remote Relay 5	0 (Off), 1 (On)	1



Ensure that all power is switched off before installing or maintaining this product

## Specifications

	Mercury Mk2 Controller PR0710-PLS	Intuitive Mercury controller PR0750-PLS
<b>Power requirements</b>		
<b>Supply Voltage Range</b>	100 - 240 Vac $\pm$ 10%	100 - 240 Vac $\pm$ 10%
<b>Supply Frequency</b>	50 - 60 Hz	50 - 60 Hz
<b>Maximum supply current</b>	5.2 Amps (when relay 5 is fully loaded)	2 Amps
<b>Typical supply current</b>	<1 Amp	<1 Amp
<b>General</b>		
<b>Operating temperature range</b>	+5°C to +50°C	-10°C to +60°C
<b>Storage temperature range</b>	-20°C to +65°C	-20°C to +65°C
<b>Environmental</b>	Indoor use at altitudes up to 2000m, pollution degree 1, installation category II. Voltage fluctuations not to exceed $\pm$ 10% of nominal voltage.	Indoor use at altitudes up to 2000m, pollution degree 1, installation category II. Voltage fluctuations not to exceed $\pm$ 10% of nominal voltage.
<b>Size</b>	78mm (W) x 36mm (H) x 110mm (D)	157mm (W) x 67mm (H) x 120 (D)
<b>Approx Weight</b>	170 grams	500 grams
<b>Safety</b>	EN61010	EN61010
<b>EMC</b>	EN61326; 1997 +Amdt. A1; 1998	EN61326; 1997 +Amdt. A1; 1998
<b>Ventilation</b>	There is no requirement for forced cooling ventilation	There is no requirement for forced cooling ventilation
<b>Class 2 Insulation</b>	<b>No</b> protective Earth is required and <b>none</b> should be fitted	<b>No</b> protective Earth is required and <b>none</b> should be fitted
<b>Supply Fuse</b>	The host equipment must provide a suitable external over-current protection device such as: - Fuse: 6.3A 240 Vac Antisurge (T) HRC conforming to IEC 60127	Built in fuse holder, fuse 2A 240Vac Antisurge (T) HRC conforming to IEC60127, 32 x 6.3mm
<b>Or MCB</b>	6A, 240 VAC Type C conforming to BS EN 60898	2A, 240 VAC Type C conforming to BS EN 60898 (Note: controller has integral 2A fuse)
<b>Relay Fuse</b>	Not Fitted	10A 240Vac Antisurge (T) HRC conforming to IEC60127, 32 x 6.3mm
<b>Relay Specification</b>		
	<b>Relays 1-4 Exclusive common</b>	<b>Relays 1-4 Exclusive common</b>
<b>Max current</b>	6A Resistive (Cos $\phi$ = 1) 2A Inductive ( Cos $\phi$ = 0.4)	10A Resistive (Cos $\phi$ = 1) 3A Inductive ( Cos $\phi$ = 0.4)
<b>Max voltage</b>	250Vac, 30V dc	250Vac, 30V dc
<b>Relay Fuse</b>	N/A	10A 240Vac Antisurge (T) HRC conforming to IEC60127, 32 x 6.3mm
	<b>Relay 5 Common connected to supply live</b>	<b>Relay 5 Exclusive common</b>
<b>Max current</b>	3A (non inductive), COS $\phi$ =0.4 2A (inductive load) 200,000 operations	10A Resistive (Cos $\phi$ = 1) 3A Inductive ( Cos $\phi$ = 0.4)
<b>Max voltage</b>	250Vac (Internal supply)	250Vac, 30V dc (external supply)
	For compliance with the LVD, relays 3, 4 and 5 commons must be at the same potential as the supply voltage	All relays are independent and can operate at different potentials to the supply voltage.



**Warning: Relay 5 output has hazardous voltages (Supply input voltage potential)**  
This does not apply to the Intuitive Mercury controller



Ensure that all power is switched off before installing or maintaining this product

## Inputs

Input switching resistance threshold: 3.01K Ohms  
 Input type: 0 Volt return

(Inputs are limited to 1.67mA and are not opto-isolated, the controller supplies 5vdc to measure the resistance.)

Comms: RS232 with flow control

## Reader Specification

Pulse High Duration: 100ms minimum  
 Pulse Low Duration: 100ms minimum  
 1 hour store maximum: 3276 counts  
 12 hour store maximum: 3276 counts  
 24 hour store maximum: 3276 counts  
 Main accumulator maximum: 9,999,999.9 counts  
 Pulse Voltage: 0v return from reader

**Note** the controller saves the current pulse counts to non-volatile memory, daily at midnight.

## Installation

### Panel Cut-out and Clearances

#### Mercury Mk2 (Flush mount controller)

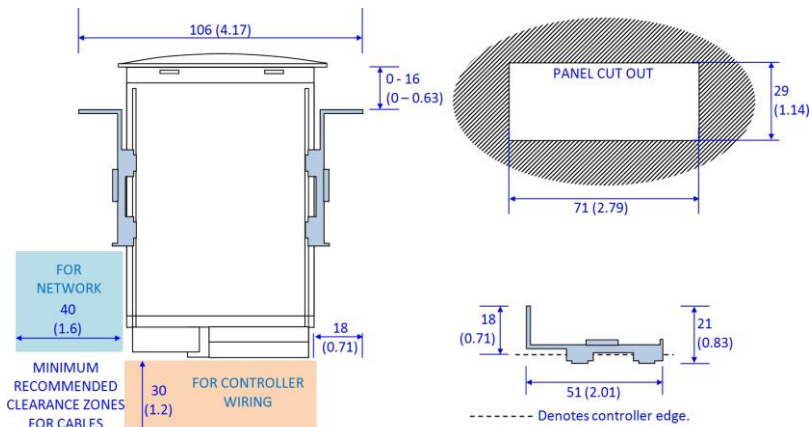

## Fixing

The controller is fixed by sliding the 2 plastic retaining clips up to rear of the panel. These clips have a ratchet action and can be removed by holding in the clip sides and sliding back.

There is no requirement for forced cooling ventilation

## Dimensions

### Mercury Mk2

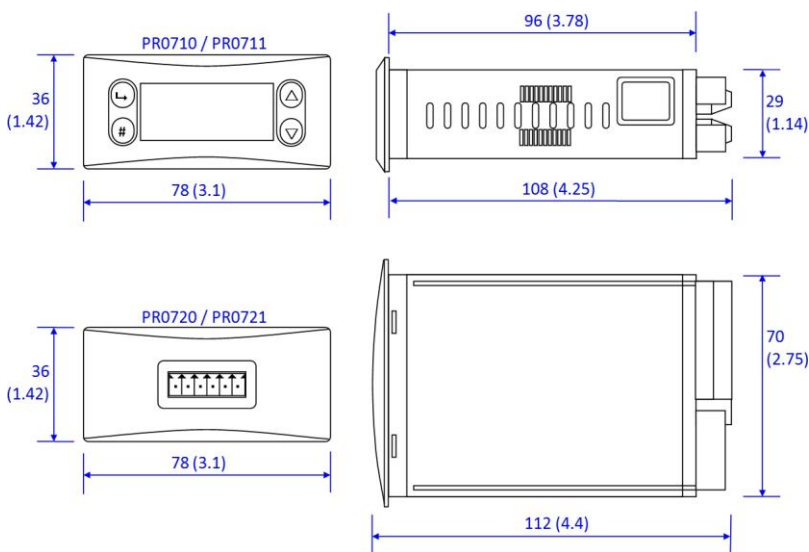

Ensure that all power is switched off before installing or maintaining this product

**Intuitive Mercury controller**

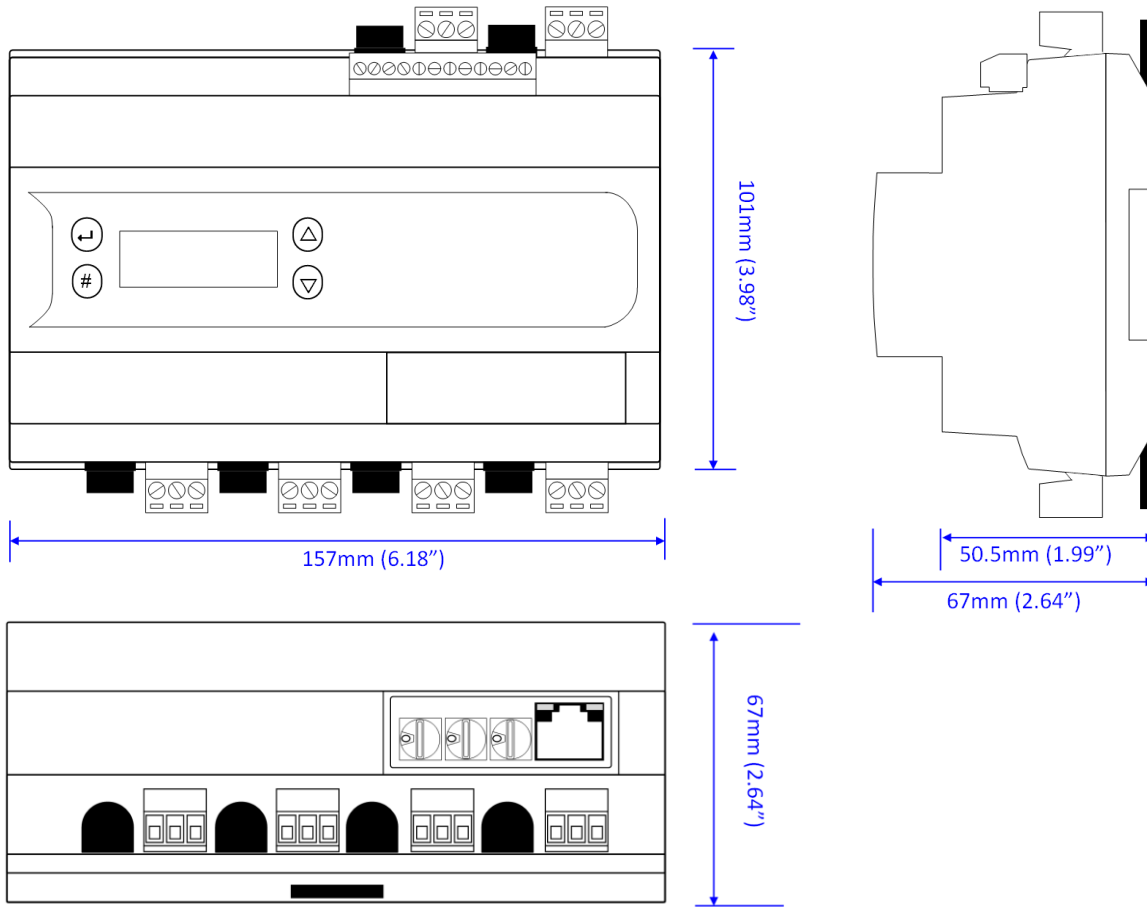

**Intuitive Mercury Mounting Instructions**

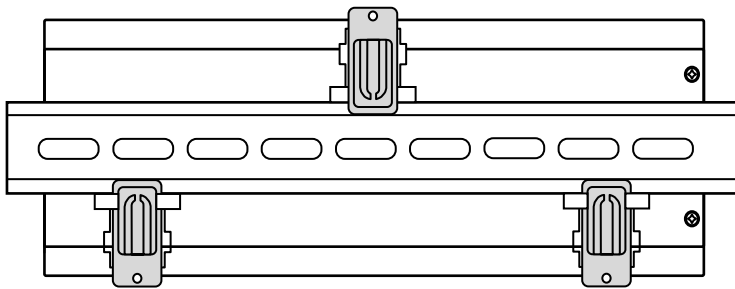

Three clips fix the Intuitive Mercury securely to DIN rail. Pull each clip until it “clicks” to remove the controller. Each clip has a mounting hole to provide an alternative fixing mechanism to DIN mounting.

**Cleaning**

Do not wet the controller when cleaning. Clean the front by wiping with slightly dampened lint free cloth.

**Disclaimer**

The specifications of the product detailed in this document may change without notice. RDM Ltd shall not be liable for errors or omissions, for incidental or consequential damages, directly or indirectly, in connection with the furnishing, performance or misuse of this product or document.



Ensure that all power is switched off before installing or maintaining this product

## Revision History

Revision	Date	Changes
1.0	28/04/2011	Introduction of Intuitive range
1.0b	24/10/2012	Input switching threshold resistance added to specifications
1.0c	03/07/2013	Explanation of scaling factor altered
1.5	27/10/2014	Wireless mesh functionality added. Also matched revision with software version
1.5a	06/01/2015	Operating temperature range updated
1.5b	12/11/2015	Input specification updated



Ensure that all power is switched off before installing or maintaining this product