

Resource  
Data Management

# Intuitive Mercury TDB Controller

## Commissioning/User Guide

### Revision 3.4

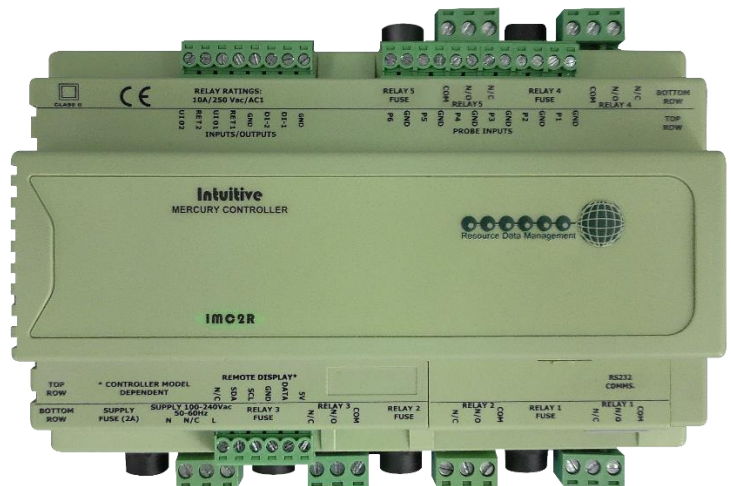

PR07XX-TDB

## Contents

The Intuitive Mercury Range.....	4
Intuitive Mercury TDB Controller.....	4
Configuration.....	4
Compatible Network Interfaces.....	4
Inputs & Outputs Descriptions.....	5
Compatible Remote Displays.....	5
Intuitive Mercury TDB Display (PR0750-TDB).....	5
Intuitive Mercury Physical IO.....	6
Intuitive Mercury Network Expansion Options.....	7
Intuitive Mercury TDB with Daughter Board Option.....	7
Daughter Board Connection Details.....	8
Ordering Information.....	9
Data Builder for the Intuitive Mercury TDB Controller Range.....	9
Getting started.....	10
Control Editor Appearance.....	11
Uploading a TDB Program.....	12
Downloading a TDB Program.....	12
Online Mode - Following Upload/ Download.....	12
Input / Output – Item Ordering.....	13
Designing the Application.....	14
General editing principles.....	14
Allowable Characters.....	14
Program Settings.....	15
Building an Application Example.....	15
Configuring the blocks.....	16
Saving the completed TDB program.....	16
Access through front Display Buttons.....	17
Setup Function Menu.....	17
PARA – Parameter Menu.....	17
rtc. - Real time clock.....	17
Net - Network Configuration.....	18
Toolbox Items.....	21
General Blocks.....	22
Selection Tool.....	22
Static Text.....	22
Magnifier Tool.....	22
Shortcut Block.....	22
Settings Block.....	23
Online Mode.....	23
Run Simulation.....	24
I/O Objects & Properties.....	25
Analogue In.....	25
Analogue Out.....	26
Digital In.....	27
Digital Out.....	28
Network Analogue In.....	28
Network Digital In.....	28
GP Timer 3 Block.....	29
Defrost Signal.....	29
State Block.....	29
Humidistat Display.....	30
Humidistat 2 Display.....	30
Logic Blocks.....	32
And blocks.....	32
OR Blocks.....	32
Not Block & Exclusive OR Block.....	32
Mathematical Blocks.....	33
(+, -, x, ÷ blocks).....	33
Absolute (abs) Block.....	33
X to the Power of Y (x <sup>Y</sup> ).....	33
Min, Max, Equals blocks.....	33
<, >, ≤, ≥ blocks.....	33
Average & Limit blocks.....	34
Range.....	34
Min, Max, Avg. Block.....	34
Filter.....	35
Accumulator Block.....	35
Algebra.....	36
Time Blocks.....	37



Please ensure all power is switched off before installing or maintaining this product.

Delay On Timer.....	37
Pulse Timer .....	37
Heartbeat.....	37
Run On .....	37
Run Hours Block.....	38
Change Over .....	38
Match Date.....	38
Date Time Block.....	39
Summer or winter .....	39
Daylight Block.....	39
Time Block .....	40
Schedule.....	40
Day of Week Block .....	40
Functional Blocks.....	41
Alarm block .....	41
Analogue Switch.....	41
Analogue Store .....	41
Pulse Counter .....	41
D-Latch.....	41
SR-Latch .....	42
Digital Edge Block .....	42
Analogue Edge Block .....	42
Reverse On/Off .....	43
Direct On/Off.....	43
Direct PID .....	44
Reverse PID.....	44
Levels.....	45
Pressure to Temperature.....	46
Comfort Block.....	46
Offline Block .....	46
Diagnostic blocks.....	47
Analogue Display Block .....	47
Digital Display Block .....	47
Custom Blocks.....	48
Creating a new Custom Block.....	48
Find/Replace .....	49
Finding an Item.....	49
Replacing an Item .....	50
Show Names .....	50
Network Analogue Input .....	51
Receiving Analogue Values from a Data Manager TDB Program .....	51
Network Digital Input .....	52
Receiving Digital Values from a Data Manager TDB Program .....	52
Refresh Timeout .....	53
Specification .....	54
Installation .....	55
Dimensions.....	55
Mounting Instructions .....	56
Clearances .....	56
Cleaning.....	56
Disclaimer .....	56
Terms of Use .....	56
Appendix 1: Comfort Index .....	57
Appendix 2: Webpage Appearance .....	58
Appendix 3: Uploading a TDB program from the Data Manager.....	60
Revision History .....	61



Please ensure all power is switched off before installing or maintaining this product.

# The Intuitive Mercury Range

From Resource Data Management

## Intuitive Mercury TDB Controller

The Intuitive Mercury Controller with Data Builder is a versatile device intended for user programming. Some example applications are HVAC, BMS and Refrigeration. As default, the device has 6 analogue probe inputs, which can also be used as volt free digital inputs, 2 digital inputs, 2 Universal I/O and 5 relay outputs with optional on board fusing. In addition, the controller can also be specified with one or more solid state relays (SSRs) fitted. There are optional daughter boards available which provide additional inputs and outputs. There is no intrinsic program, but all of the inputs and outputs are available for use with either the on-board Data Builder program or a Data Manager Data Builder program to provide the ultimate flexibility in control and monitoring applications.

The Intuitive Mercury TDB requires an IP connection for uploading/ downloading TDB programs to the device. There is a maximum of 2048 blocks available for use in a program, though this can be less depending on the type of blocks used. Up to 64 external Setting Blocks are allowed in a program, if more than 64 Setting Blocks are used then the additional blocks will not appear in the controller webpage's or on an RDM Data Manager. Any additional Setting Blocks used must be marked as 'Internal'.

There can be a total of 20 alarm Blocks and a total of 20 External I/O. If more than 20 I/O blocks are required they would have to be set as internal.

Due to the flexibility of the TDB Editor it allows a user to create complex control strategies. RDM recommend that the developer of the TDB application carry out functionality tests prior to installation to ensure the control strategy designed operates as expected e.g. all inputs can be read, all outputs activate when operated by the TDB program and so forth. If the unit is to be connected to a Data Manager, RDM recommend the developer also log on the controller to a Data Manager, for example to check the order of Inputs, Outputs and parameters.

Description	Part Number
Intuitive Mercury Controller with TDB application, integral display	See <a href="#">Ordering Information</a>
Intuitive Mercury Controller with TDB application, remote display	See <a href="#">Ordering Information</a>

## Configuration

The controller has no configuration until a Data Builder application has been developed and uploaded to the controller, see: [Getting started](#).

## Compatible Network Interfaces

Intuitive Mercury controllers are capable of connecting to a TCP/IP local area network, or they can be used in standalone mode with no network connection. To connect to a network the correct communications module must be used.

The Intuitive Mercury TDB Controller is supplied as standard with an internal RS232 network card. As alternatives, either an [Ethernet interface](#) or a [Wi-Fi network](#) card is available, these can be supplied factory fitted as an option or purchased separately as an interface kit;

Description	Part Number
Intuitive Internal IP Network Card Interface Kit	PR0770
Intuitive Wi-Fi Network Card Interface kit (External Antenna)	PR0769-EXT

Alternatively, with the standard RS232 interface the below optional external network interfaces can be used;

Description	Part Number
IP Futura (Single Mercury to IP Interface)	PR0016
Mercury IP Switch (IP support for 10 controllers)	PR0018
Mercury IP Switch with Pressure/Humidity Inputs	PR0018-PHI

Connecting to any of these communication modules will automatically be detected on power up and will affect the set up screens available.



Please ensure all power is switched off before installing or maintaining this product.

## Inputs & Outputs Descriptions

Inputs / Outputs	Description	Comments
Analogue/Digital Input 1 - 6	Probe input	See note 1
Digital Inputs 1 - 2	Digital Inputs	Volt Free
Universal I/O 1 - 2	mA / V Input or Output	
Relays 1-5	N/O, N/C and Common	Volt Free

- Note 1 A variety of probes can be used by the Data Builder Analogue block or a custom probe curve can be programmed. These inputs can also be set to digital with a settable switching threshold (default 1000 ohms).
- Note 2 See [Daughter Board](#) section for additional I/O.

## Compatible Remote Displays









When using the remote display variant of the controller the following displays are compatible.

Description	Part Number
Mercury Mk2 Display	PR0725
Humidistat Display	PR0445

## Intuitive Mercury TDB Display (PR0750-TDB)

Front Display Features

### LED's:

- Valve Icon 
- Fans Icon 
- Lights Icon 
- Defrost Icon 
- On-Line 
- Service 
- Alarm 
- HACCP 

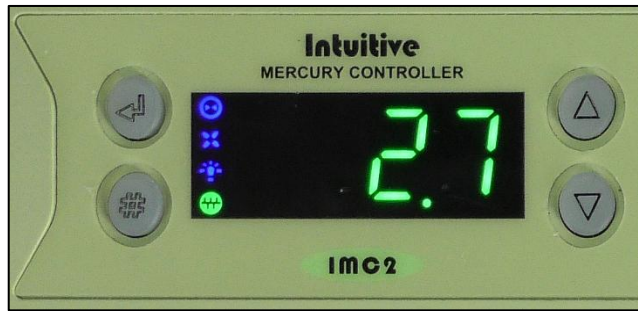

4 character LED display  
 When viewing numerical values on the display it will allow from -99.9 to 999.9 or -999 to 9999 depending on units selected. All values out with these bounds will show N/A on the display.



Please ensure all power is switched off before installing or maintaining this product.

## Intuitive Mercury Physical IO

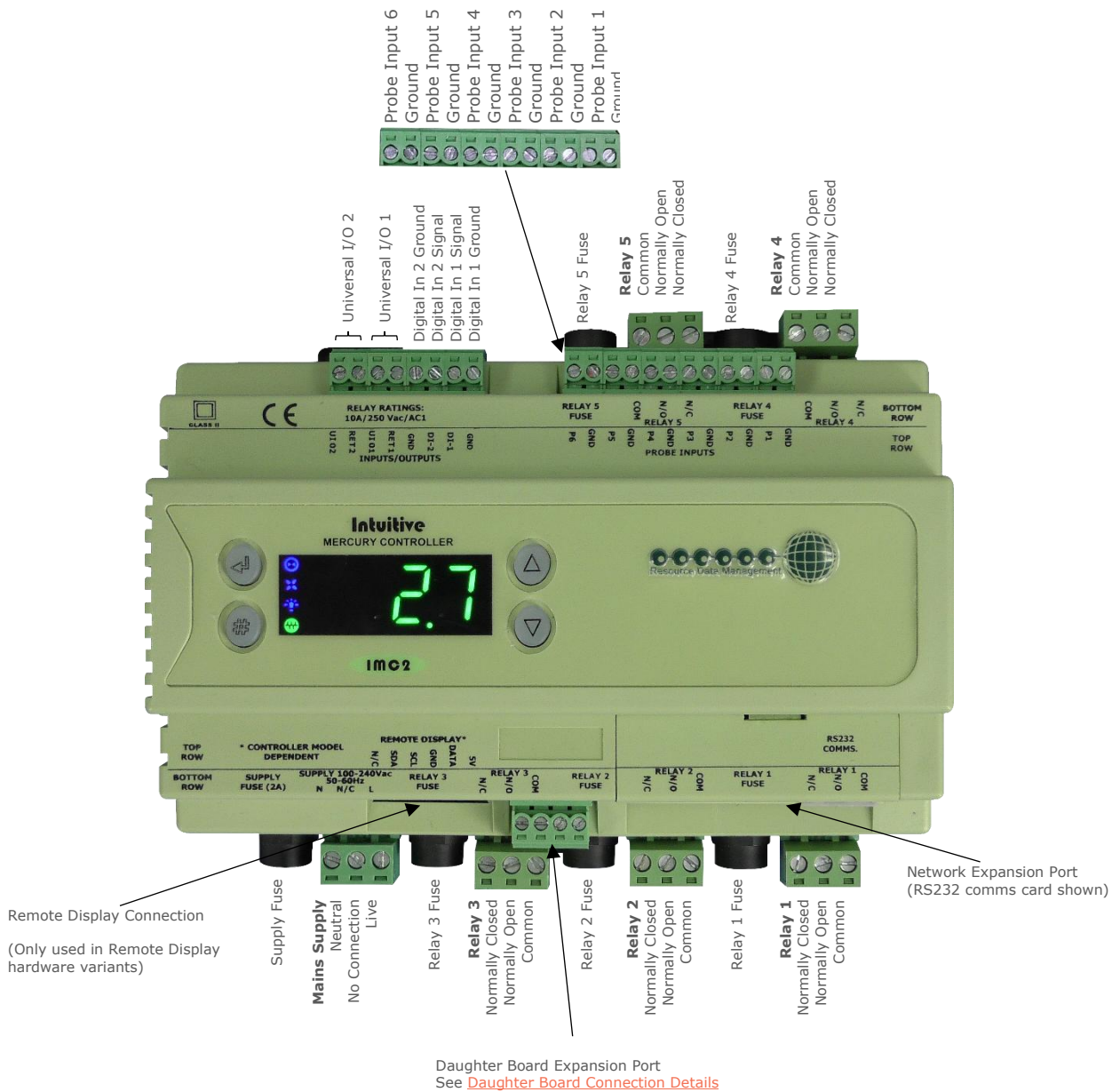

Universal IO Type	Universal RET	Universal UI
4-20mA Input	mA Signal In	12V dc Out
0-10V Input	Ground	Sig In
4-20mA Output	Ground	Sig Out
0-10V Output	Ground	Sig Out

All inputs and outputs are plug and socket. The supply voltage and relay outputs have individual fuse protection.

### Optional Solid State Relay

If a solid state relay is fitted in any position then the common feed is connected to the common terminal and the switched output is connected to the N/C terminal, the N/O terminal is not used. The solid state relay will only switch AC voltage, it will not switch DC voltage.



Please ensure all power is switched off before installing or maintaining this product.

## Intuitive Mercury Network Expansion Options

### RS232 Network Card (Default)



The Intuitive Mercury is supplied with an RS232 Network Card fitted as standard. Some example optional network cards are shown below

### IP Network Card (PR0770)



Rotary Address Switches  
Network Collision LED  
Network Activity LED

### Wi-Fi Network Card (PR0769-EXT)



### Wi-Fi Network Card (PR0769-INT)



Network Activity & Status LED

## Intuitive Mercury TDB with Daughter Board Option

The Intuitive Mercury TDB controller can be purchased with optional daughter boards to expand on the controller's standard I/O. The controller can be fitted with a single daughter board, the types of daughter boards which are currently available and their part numbers are shown below.

**Important:** Please note the daughter boards are a factory fit option only and must be ordered with the controller.

Daughter Board Options	Connector Colour *
3 x Temperature Probe Input Expansion board	Green
1 x 0-5V/0-10Vdc Input & 1 x 0-5V/0-10Vdc Output board	Blue
2 x 0-5V/0-10Vdc Input board	Orange
2 x 0-5V/0-10Vdc Output board	Orange
2 x 4-20mA Output Board	Black
1 x 4-20mA Input & 1 x Probe Input Expansion board	Black
1 x 0-5/0-10Vdc Input & 1 x Probe Input Expansion board	Blue
1 x 4-20mA Input & 1 x 4-20mA Output board	Black
1 x Relay Output board	Green

\*Each daughter board comes with a colour coded connector as a visual indication.



Please ensure all power is switched off before installing or maintaining this product.

## Daughter Board Connection Details

3x Temperature Probe Input



1x 0-5V/0-10Vdc Input & 1x Probe Input

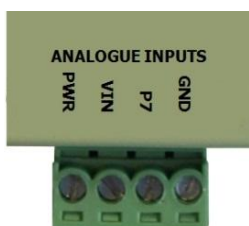

1x 4-20mA Input & Probe Input

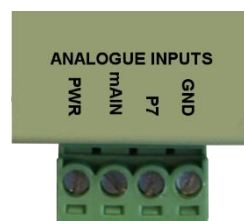

2x 0-5V/0-10Vdc Input

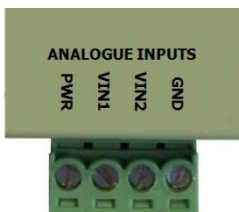

2x 0-5V/0-10Vdc Output

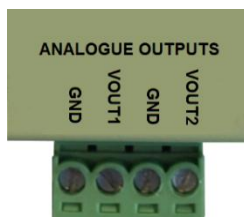

1x 0-5V/0-10Vdc Input & 1x 0-5V/0-10Vdc Output

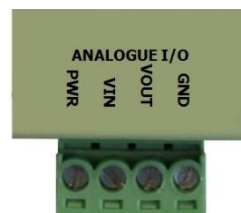

1x 4-20mA Input & 1x 4-20mA Output

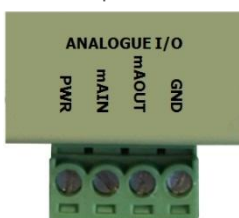

2x 4-20mA Output

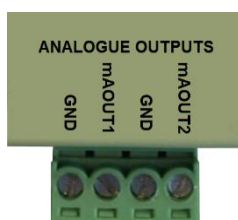

1x Relay Output

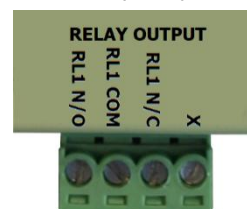

**Note:** 'PWR' is a constant voltage output for external equipment, supply voltage is dependent on the board type, see the specification section for more details. GND is a common ground for all inputs and outputs.



Please ensure all power is switched off before installing or maintaining this product.

## Ordering Information

When ordering an Intuitive Mercury TDB controller the following ordering scheme can be used to purchase the desired hardware configuration. This ensures the controller ships with the optional hardware pre-fitted.

**PR07VW X TDB Y Z** Where **W, X, Y** and **Z** are selections from the tables below;

V	Description
5	Internal Display
6	Remote Display

W	Description
0	Relay 1 Mechanical
1	Relay 1 Solid State
12E	Relays 1 & 2 Solid State
13E	Relays 1, 2 & 3 Solid State
14E	Relays 1- 4 Solid State

X	Description
	Fused
NF	No Fuse

Y	Description
	RS232*
IP	IP Interface
WiFi-I	Wi-Fi Interface with Internal Antenna
WiFi-E	Wi-Fi Interface with External Antenna

\*\* If no daughter card required leave field blank

Z	Description
	No Daughter Card**
3P	3 x Temperature Probe Inputs
Vi/Vo	1 x 0-5V/0-10Vdc Input & 1 x 0-5V/0-10Vdc Output
2xVi	2 x 0-5V/0-10Vdc Inputs
1PVi	1 x 0-5/0-10Vdc Input & 1 x Probe Input
Ai/Ao	1 x 4-20mA Input & 1 x 4-20mA Output
1PAi	1 x 4-20mA Input & 1 x Probe Input
2xVo	2 x 0-5V/0-10Vdc Outputs
2xAo	2 x 4-20mA Outputs
1xMR	1 x Relay Output

Example – To order a remote display variant with a mechanical relay in position 1, a built in IP module and 3 x temperature probe input board use the following part number:

**PR0760 TDB IP 3P**

## Data Builder for the Intuitive Mercury TDB Controller Range

The Data Builder (TDB) is a user-friendly programming tool for developing applications to run on an Intuitive Mercury TDB Controller. The Data Builder has a vast library of functional parts that allow the user to build simple or sophisticated applications, which can be 'run' on the controller hardware. There is a simulation option that allows for the completed application to be fully simulated and de-bugged before going 'live'.



Please ensure all power is switched off before installing or maintaining this product.

# Getting started

To work with the Intuitive Mercury TDB controller you must have RDM TDB Control Editor Software version **V2.3.0** or higher.

It is not possible to edit the TDB program directly through the controller webpage interface, this is done using the standalone editor. It is only possible to communicate with the controller via an IP connection. To upload or download a TDB program the controller must have an IP address, this can be manually assigned or the controller can receive this from a DHCP server. Please see the [Network Configuration](#) section for further details. Once the controller has been assigned an IP address a program can then be developed using TDB Control Editor and uploaded to that IP address.

To obtain the latest TDB Control editor software navigate to the Resources section of the Resource Data Management website.

[www.resourcedm.com](http://www.resourcedm.com)

Once installed start the control editor software application, a typical screen shot is shown below.

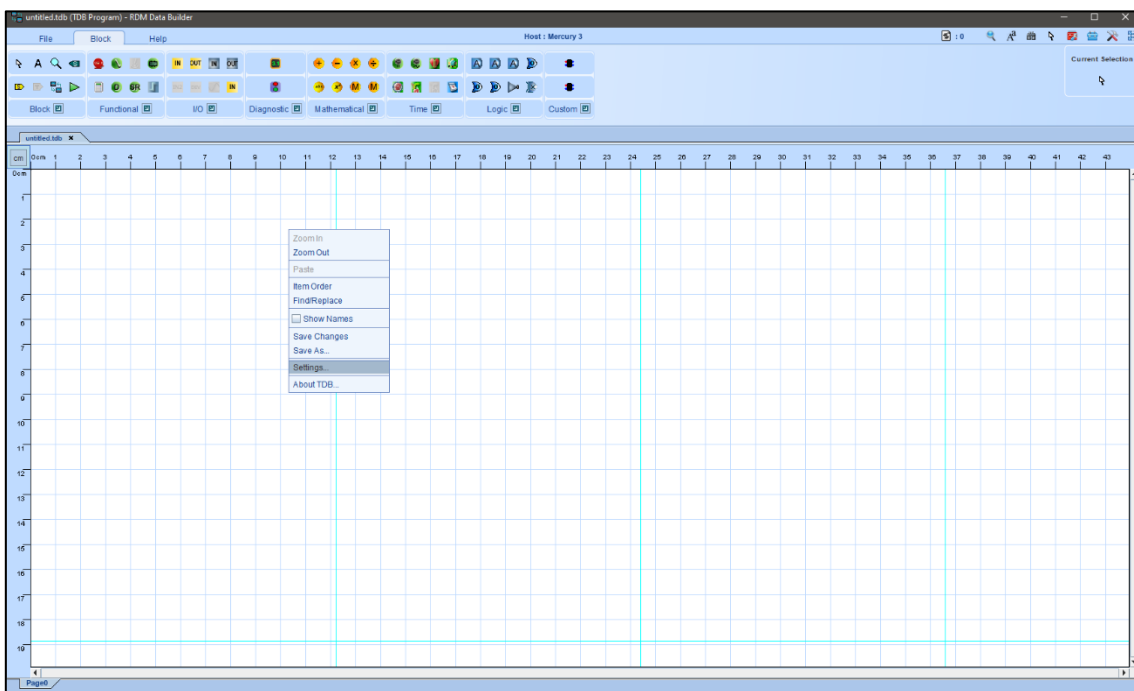

Right click in work space and select 'Settings' from the list of options.

From the Program Settings menu, firstly select the correct 'Host', which is 'Mercury 3'. Then from within the same settings menu, select the appropriate 'daughterboard' if one is fitted. See the below example

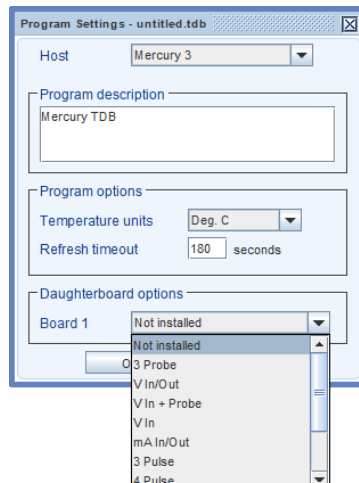

Please ensure all power is switched off before installing or maintaining this product.

## Control Editor Appearance

The initial view within the Desktop Editor will show no logic or blocks until the user adds them.

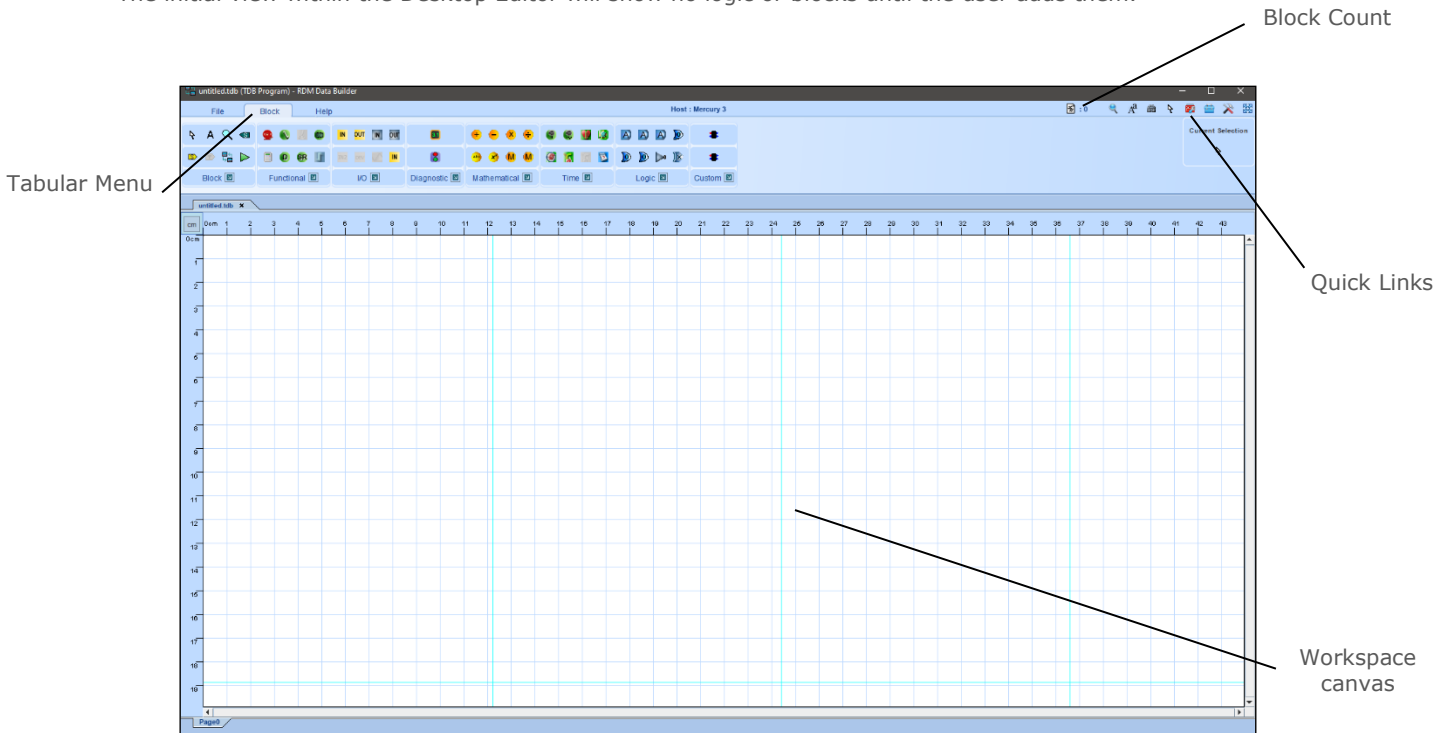

From within the Desktop Editor the user's program can be developed.

**Note:** There are a maximum of 2048 blocks available for use in a program, though this can be less depending on the type of blocks used.

**Note:** There can be 64 visible parameters allowed in the program (If more than 64 Setting Blocks are used they would have to be set as Internal).

**Note:** There can be up to 20 external I/O available (If more than 20 are used they would have to be set as internal).

**Note:** There can be a maximum of 20 Alarm Blocks in a program.

Each of the Controller inputs and outputs has a corresponding Data Builder block allocated. These can be used to start developing your application.

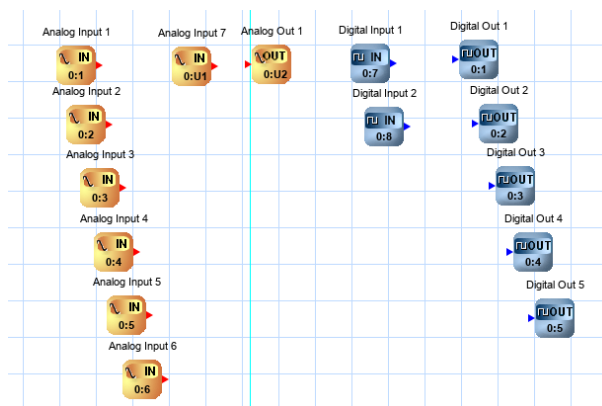

For the complete instructions of all features within the TDB desktop Editor please consult the Editor's User Guide, this can be found in the Resources section of the Resource Data Management website. This guide will highlight the main features used in programming the Intuitive Mercury Host.



Please ensure all power is switched off before installing or maintaining this product.

## Uploading a TDB Program

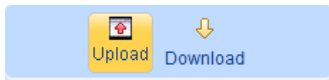

Once a program has been created within the editor it can then be sent to the desired Intuitive Mercury TDB. Open the TDB program to be loaded, from the 'File' menu select 'Upload' and the below screen will appear.

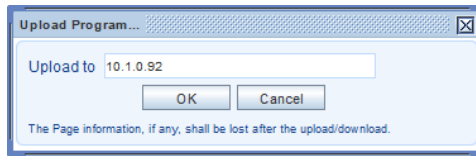

From within the field, type in the IP address of the controller connected to the PC and click 'OK', after a short delay a message will appear to indicate the program has been successfully sent to the IP address entered (to assign the controller an IP address see [Network Configuration](#)).

## Downloading a TDB Program

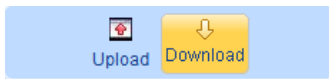

To retrieve a TDB program from a connected Intuitive Mercury from the 'File' menu select 'Download' and the following screen will appear.

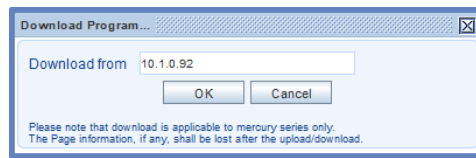

From within the field, type in the IP address of the controller connected to the PC and click 'OK', after a short delay a message will appear to indicate the program has been successfully downloaded from the IP address entered.

## Online Mode - Following Upload/ Download



Once the TDB program has been uploaded or downloaded to the controller, from within the Desktop Editor, the user has the ability to select 'Online Mode' as long as the device remains connected. Online mode will allow the user to view the values and states of the blocks within the TDB in real time.



Hovering the pointer over the connecting wires while in 'Online Mode' will indicate the current value, similar to above. To stop 'Online Mode', click the icon again.

**Note:** If any amendments have been made to the TDB program, it would have to be saved and re-uploaded before 'Online Mode' could be used again.



Please ensure all power is switched off before installing or maintaining this product.

## Input / Output – Item Ordering

### Automatic

The inputs, outputs and parameters will be automatically ordered in accordance to the block positioning on the TDB canvas. Priority is given to the blocks as they appear from left to right. If two blocks share the same 'X-axis coordinates' then priority is given to the block that appears first when viewed from top to bottom. An example is shown below.



When the above blocks are viewed within the IO list they will show;

Digital Input 1	Digital Input 2
Digital Input 2	Digital Input 1

As shown above, 'Digital Input 1' appears first in the control summary (left column) as it is the first block to appear when viewing from left to right. 'Digital Output 2' appears at the top of the control summary table (right column) as both blocks are equally placed from left to right but 'Digital Output 2' appears first when viewed top to bottom.

### Manual

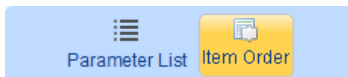

The Inputs, Outputs and Parameter order listings can be changed manually if required. Either by clicking on the 'Item Order' button from within the 'File' menu or by right clicking on the workspace and selecting 'Item Order' it will bring up the 'Item Order' menu. This menu has tabs at the top for Inputs, Outputs and Parameters.

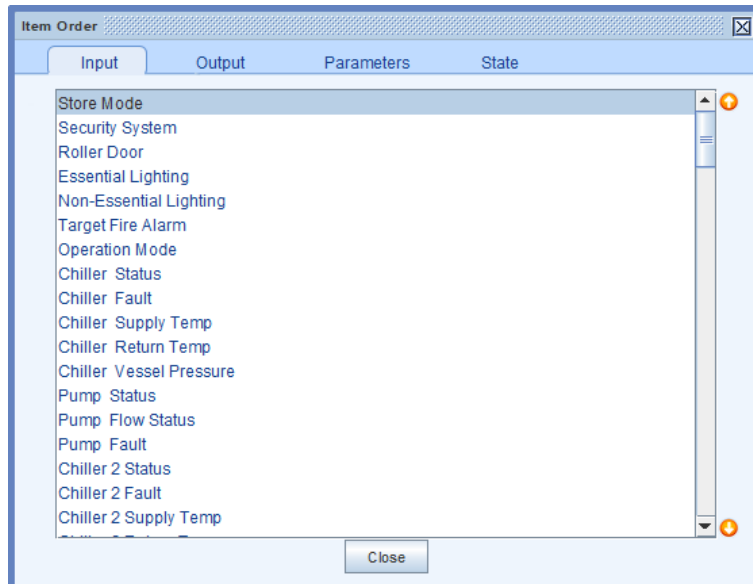

Selecting the appropriate tab will give a list of current Inputs, Outputs or Parameters. Highlight the item to be moved and click on the up and down arrow boxes on the right to move the item up or down the list to confirm the desired order.





The Inputs, Outputs and Parameter order listings can be changed manually if required.

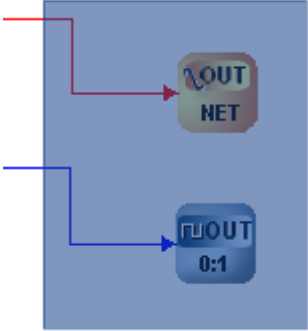
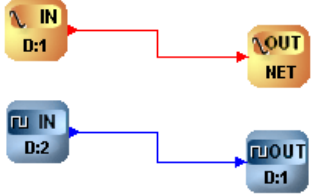

Please ensure all power is switched off before installing or maintaining this product.

## Designing the Application

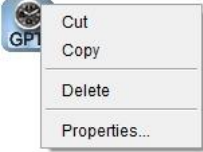
### General editing principles

Mouse Action	Result
Left double click on object	Opens object properties box
Left click and hold-drag-release	Moves object
Left click on canvas, hold-drag-release (with selection pointer)	<p>Selects the objects under the selection area.</p> 
<p>Left click hold-drag-release on wire connection points (nodes) Blue points to blue, or red to red</p> <p>Note: Red to blue and blue to red connections are not allowed</p>	<p>Wire objects point to point</p> 
Left click hold-drag-release on wire connection, then workspace (not a node)	Unwires object
<p>Right click on object</p> 	<p>Sub menu:</p> 
Right click on workspace (i.e. not on an object).	<p>Sub menu:</p> 

### Allowable Characters

**IMPORTANT NOTE:**

Any text used to name a block within TDB editor must be alphanumeric and cannot use non-standard English characters, for example, A b c D X y Z are allowable, - + : \$ ¤ Æ Ö are not. Blocks with non-alphanumeric characters contained in them may not operate correctly. Text blocks used in a program do not have any functional use, so are not affected by non-alphanumeric characters.



Please ensure all power is switched off before installing or maintaining this product.

## Program Settings

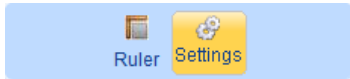

By either clicking on the 'Settings' button from within the 'File' menu or right click on the work space and select 'Settings'. The Program Settings window will be shown similar to below.

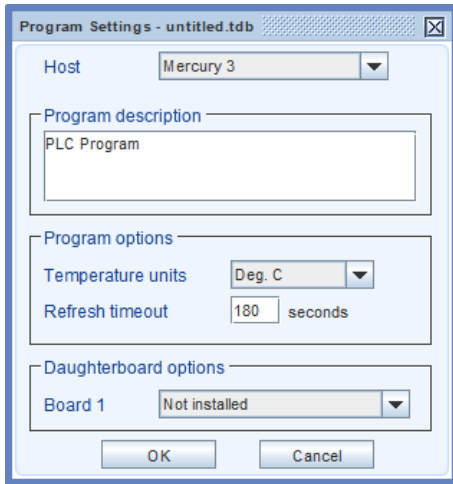

### General Settings

**Host:** For the Intuitive Mercury TDB, ensure 'Mercury 3' is selected.

**Program Description:** Enter a suitable description for the TDB program being created.

**Program Options Temperature Units:** Select between Degrees Celsius or Fahrenheit operation from the drop down list. This will affect all temperature related IO blocks.

**Refresh Timeout:** Enter a time in seconds. This is used with certain TDB blocks such as Network Inputs.

### Daughterboard

**Options**  
The Intuitive Mercury can be factory fitted with an additional daughterboard providing additional IO for the TDB to use. Please see [Daughterboard Expansion Options](#). Select the appropriate daughterboard installed on the device the TDB is intended.

### Board 1:

## Building an Application Example

Using the tools provided in the editor, select and place objects onto the workspace then connect blocks where necessary to create the logic required for your application. Using their [properties](#) box, set the appropriate values. Once any logic has been created run a [simulation](#) to prove the design; see simulation.

Once the design is complete, [save your application](#); see saving design.

## Frost Alarm

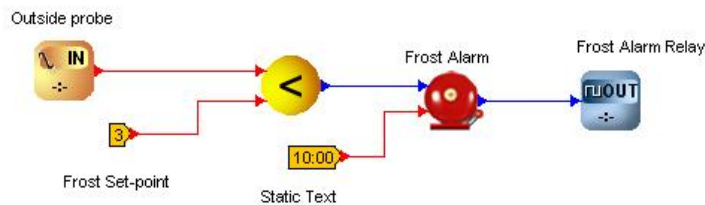

The above diagram shows a simple Data Builder application for a frost alarm. An outside temperature probe is connected to an analogue input and this is compared to a frost set-point. If the temperature goes below this set point (using a less than block) the output of the less than block goes on. This goes to the alarm block that has a delay of 10 minutes. If the signal is still on after the 10 minutes, the relay will be energised.



Please ensure all power is switched off before installing or maintaining this product.

## Configuring the blocks

Each type of block has an associated properties box which can be edited to configure the block and the way it will operate while the program is running. Depending on the 'host' selected to implement your application, will dictate some of the property fields and their associated values. To offer a general example of a typical properties box see below (Analogue Input);

**Name:** Type in the Name of the Item or leave as default.

**Min:** Minimum value that will be displayed on the web page summary screen of controller or Data Manager. Values below this value will show '????'.

**Max:** Maximum value allowed that can be displayed on the web page summary screen of controller or Data Manager. Values above will show '????'.

**Scale:** This field will be fixed and dependant on the Units selected.

**Units:** Select the type of unit to be associated to the block (e.g. Deg. C, bar etc.).

**Low/ High:** These are adjustable limits the user can set and if the input's value goes out with them, the value will automatically take the 'Default' value.

**Default:** Static value the input will display if the input goes out with the Low/ High limits.

**Internal:** Check the box to prevent the Block/ Setting/ Item from being displayed in the summary screen of controller or DM.

**Type:** On the Intuitive Mercury the 'Type' will always be 'Fixed'. It will allow the user to associate a hardwired probe from the device.

**Board:** The Intuitive Mercury TDB allows for an expansion daughter board (See [ordering information](#)). Selecting 'Board 0' will list the available IO on the main Intuitive Mercury. Select 'Board 1' to select the IO from the daughter board.

**Probe:** With the desired board selected choose the physical probe location and associated probe type connected to the hardware.

**Simulation Setting:** While in 'simulation mode' this will be the value the block will possess. Note: the value can be changed during the simulation.

For further info on the 'Analogue Input' block please see the [Toolbox Items](#) section.

## Saving the completed TDB program

Once the design is complete, it can be saved by clicking on the 'Save As' button within the 'File' menu. Once the location has been selected, the password dialogue box allows the user to enter a Read or Edit password. The password feature is unused by leaving all fields empty.

Read Password	Prevents a user from viewing/editing the TDB program within the Mercury TDB controller unless a valid Read password is entered first.
Edit Password	Allows a user to view the TDB program within the controller but not make changes to the program unless a valid Edit password is entered.



Please ensure all power is switched off before installing or maintaining this product.

## Access through front Display Buttons



To enter the setup menus, hold the Enter and Down buttons together for approximately 3 seconds until the message 'Ent' appears on the display.

Press the Enter button again to enter the function menu. rtc will be displayed.

Scroll up or down to go through the list.

## Setup Function Menu

Display	Option	Explained in Paragraph
PArA	Set the parameters (if programmed)	<a href="#">Parameter Menu</a>
rtc	Set/view Clock (rtc = Real Time Clock)	<a href="#">Real Time Clock</a>
nEt	Set/view network configuration	<a href="#">Network Configuration</a>
SoFt	View software version	
ESC	Escapes Menu	

## PArA – Parameter Menu

The parameter menu is available to alter settings from either, the internal or remote display, attached to the controller. When creating a TDB program, the user can add a number of setting blocks that will be visible through the parameters list. When viewing the parameter menu via the display, it will list all parameters in order P-01, P-02...P-99. The ordering of which can be altered from within the editor before uploading it to the device. The configuration of the setting block will dictate the setting's lower and upper bounds along with the units.

## rtc. - Real time clock

The Real Time Clock (rtc) will automatically synchronise on network systems. This setup is only required in standalone systems.

- Use the up or down buttons to scroll through the display until the display reads 'rtc'
- Press enter. The display will show 't-1'. press enter again
- Scroll hours up or down (0 – 23) press enter
- Use up button to select 't-2', press enter
- Scroll minutes up or down (0 – 59) press enter
- Repeat for t-3 (seconds 0 – 59)
- Repeat for t-4 (Days up to 31)
- Repeat for t-5 (months up to 12)
- Repeat for t-6 (Year up to 99)
- Use up button to display 'ESC', press enter to display 'rtc'

**Time clock is now set**



Please ensure all power is switched off before installing or maintaining this product.

## Net - Network Configuration

When logging an Intuitive Mercury TDB with an RS232 interface onto a network it must first be connected to a communications module, this can be either an IP Futura module or Mercury Switch. Alternatively the Intuitive Mercury TDB can be fitted with a communications daughter card see [compatible network interfaces](#). For connection to a Mercury Switch (Hub) or an external network interface, the standard fitment RS232 network card is utilised.

### IP Futura module / Intuitive Internal IP Network card

In an IP system there are two options;

- IP-L – setting rotary address of module to 000
- IP-r – setting rotary address of module to a unique number that is not 000

IP-L allows the user to statically assign an IP address in the controller which could be used, for example, when connecting the controllers onto a customer's local area network that does not use DHCP.

IP-r allows the network ID (rotary switch address) to be used by a system running a DHCP server (for example the RDM Data Manager) to issue out an IP address automatically.

#### IP-L

To configure the communication module or network card for IP-L, set all three rotary switches to zero. The module should then be connected to the controller. In the case of an Intuitive Mercury controller where the network card is already fitted, the controller should be powered off, all three rotary switches set to zero and the controller powered on.

- From within the device's display navigate to the 'nEt' menu and press the 'enter' key.
- 'IP-L' will be displayed, press enter again.
- The user can now set the address using the table below

Display	Option
IP-1	IP Address byte 1
IP-2	IP Address byte 2
IP-3	IP Address byte 3
IP-4	IP Address byte 4
nL	Network Mask Length (see the network mask length table above)
gt-1	Gateway Address byte 1
gt-2	Gateway Address byte 2
gt-3	Gateway Address byte 3
gt-4	Gateway Address byte 4
ESC	Exit network menu. <b>N.B.</b> this option <b>must</b> be selected to save any changes made in this menu

To ease setup, a single network mask length value is used. If the address has been specified with a network mask value in dotted IP format e.g. 255.255.255.0 then the table below gives the conversion:

Mask	Length	Mask	Length	Mask	Length
		255.255.254.0	23	255.254.0.0	15
255.255.255.252	30	255.255.252.0	22	255.252.0.0	14
255.255.255.248	29	255.255.248.0	21	255.248.0.0	13
255.255.255.240	28	255.255.240.0	20	255.240.0.0	12
255.255.255.224	27	255.255.224.0	19	255.224.0.0	11
255.255.255.192	26	255.255.192.0	18	255.192.0.0	10
255.255.255.128	25	255.255.128.0	17	255.128.0.0	09
255.255.255.0	24	255.255.0.0	16	255.0.0.0	08



Please ensure all power is switched off before installing or maintaining this product.

## IP-r

To configure the communication module for IP-r, set the three rotary switches to give each controller a unique identifier. The module should then be connected to the controller and the network. In the case of an Intuitive Mercury controller where the network card is already fitted, the three rotary switches must be set when the controller is powered off, then power up before connecting to the network. To view the issued IP address from the DHCP server;

- Select 'nEt' from the function menu and press the 'Enter' key.
- 'IP-r' will be shown, press enter again
- Similar to the [tables](#) above, the network details can be viewed.

## Mercury Switch

When the controller is connected to a Mercury switch it will give the same menus as outlined in the section above. The network ID assigned to the switch via the rotary switches will dictate the menu (IP-L / IP-r). Please refer to the Mercury Switch user guide, which can be obtained from the RDM website, for information regarding connecting a controller to a network.

## Wi-Fi Network card

When a Wi-Fi network card is fitted, it allows the controller to log on to an IP network wirelessly either by statically assigning an IP address or allowing a dhcp server to automatically hand one out. It is designed to connect to a Wi-Fi access point using WPA or WPA2 security using a pre shared key. By default, the board is configured to connect to a Wi-Fi network with SSID '**RDMInstall**' and passphrase '**RDMInstall**'.

To configure the controller for operation with another Wi-Fi network requires the key to be programmed into the Intuitive Mercury. This is done through the 'Set New Key' option, in 'Wi-Fi setup' from the configure menu on the controller's web page.



Communicating with the controller and gaining access to the controller's web page can be done in three ways;

- Setting up a Wi-Fi access point with SSID and passcode 'RDMInstall' / RDMInstall' and using the default settings of the controller.
- Temporarily using an Ethernet board in the intuitive controller to first connect to a wired IP network.
- Temporarily using an RS232 communication board to connect serially to a PC running the Communicator software.

The addressing mode, the ID and the IP address can also be viewed or configured through the '[net](#)' menu of the controller via the controller display, but only when the Wi-Fi comms board is plugged in.

**Note:** The Wi-Fi key can only be entered through the controller's web pages.



Please ensure all power is switched off before installing or maintaining this product.

## Wi-Fi Key

The Wi-Fi key that is set into the intuitive controller is a single 64 digit hex key. This key is a coded combination of the Wi-Fi network SSID and the passphrase.

The key can be calculated/ generated using a specific WPA PSK generator. One such generator can be found at <http://www.wireshark.org/tools/wpa-psk.html> although there are other such sites. This type of generator uses the SSID and passphrase to generate the required 64 digit key by the controller. The key should be copied and pasted into the Intuitive controller's settings.

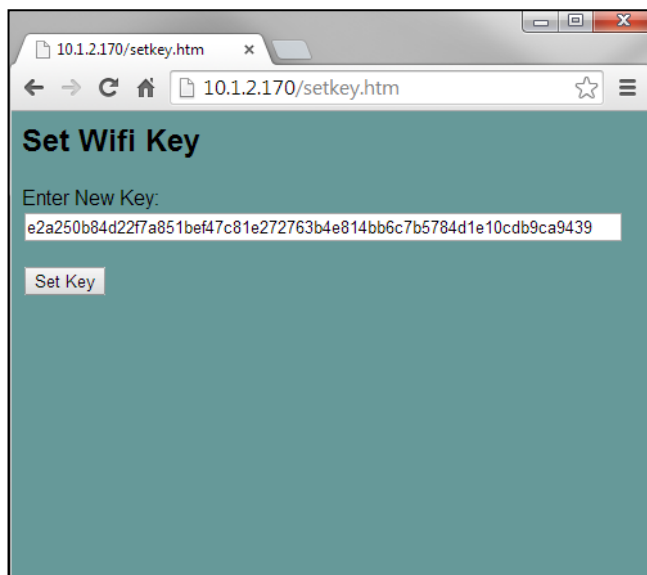

Once the Wi-Fi key is set, it is no longer visible for security reasons. The Wi-Fi field within the setup page will show 'set' rather than 'default' when the key has been set.

## Wireless Net menu

When a Wi-Fi communications board is connected to the Intuitive Mercury controller, the 'Net' menu on the display is extended to allow configuration. The net menu options will now be;

IP-r (or IP-L)	Same as existing <a href="#">IP network menu</a> . Allowing to view and set (if local) of IP address
Id	3 digit setting – replacing the three rotary switches on the Ethernet board.
AtYP	Set the address type – either local ( <a href="#">IP-L</a> ) or remote ( <a href="#">IP-r</a> ).
Stat	Shows the status of the Wi-Fi key – either default (dFLt) or set (Set)
dFLt	Allows the Wi-Fi key to be set back to default (RDMInstall / RDMInstall)

## Wireless Network Card LED operation

The LED within the card is capable of showing red or green.

Blinking green:	Healthy with data transfer.
Red / green:	Attempting to log on to a network.



Please ensure all power is switched off before installing or maintaining this product.

## Toolbox Items

The TDB Desktop Editor has many tools to create and develop bespoke applications, all of which are detailed in its in-built User Guide. All blocks available for the Intuitive Mercury TDB are categorised in to different types, simplifying locating the block required, they include; General, Logic, Diagnostic, Mathematical, Time, I/O, Functional and Custom.

The sub-menu choices for each category are listed below;

### General

- Selection Tool
- Static Text
- Magnifier
- Shortcut Block
- Settings Block
- Tag Block
- Online Mode
- Run Simulation

### IO

- Analog In
- Analog Out
- Digital In
- Digital Out
- Network Analogue In
- Network Digital In
- GP Timer 3 Block
- Defrost Signal
- State Block
- Humidistat Display Block
- Mercury Display Block

### Logic

- 2-AND Block
- 3-AND Block
- 4-AND Block
- 2-OR Block
- 3-OR Block
- 4-OR Block
- NOT Block
- XOR Block

### Functional

- Alarm Block
- Analog Switch
- Analog Store
- Pulse Counter
- D-Type Latch
- SR Latch
- Digital Edge Block
- Analogue Edge Block
- Reverse On/Off
- Direct On/Off
- Direct PID
- Reverse PID
- Levels Block
- P to T Block
- Comfort Block
- Offline Indicator

### Mathematical

- Add
- Subtract
- Multiply
- Divide
- Absolute
- X Power Y
- Min Block
- Max Block
- Equals Block
- Less-Than Block
- Greater-Than Block
- Less-Than-Or-Equals Block
- Greater-Than-Or-Equals Block
- 2-Average Block
- 3-Average Block
- 4-Average Block
- Limit Block
- In Range Block
- Min/Max/Avg Block
- Filter Block
- Accumulator
- Algebra

### Diagnostic

- Analogue Display
- Digital Display

### Time

- Delay Timer
- Pulse Timer
- Heartbeat
- Run On Block
- Run Hours Block
- Change Over Block
- Match Date Block
- Date Time Block
- Summer Winter
- Daylight Block
- Time Block
- Schedule Block
- Day of Week

### Custom

- Custom Blocks



Please ensure all power is switched off before installing or maintaining this product.

## General Blocks

### Selection Tool

Icon	Properties
	Once selected it can be used to select individual or multiple blocks, drag and drop to move objects and link objects with 'wires'.



### Static Text

Icon	Properties
	Select the 'text' block to write lines of text on the workspace canvas. Once selected, left click where the text is to be placed. 'Double clicking' on or 'right click' on the 'Static Text' and selecting properties, will open the Static Text Properties window. From here you can input the text string that is to be written on the canvas and choose text style and size. It will provide a sample of the text style to illustrate how it will appear on the canvas.

### Magnifier Tool

Icon	Properties
	When selected, the 'left click' and 'right click' will zoom in and zoom out respectively of the canvas offering different perspectives of the program.

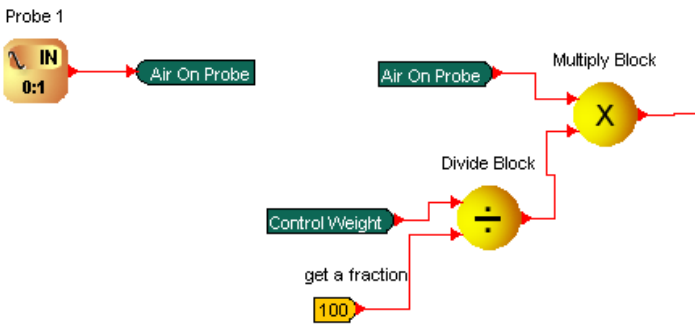
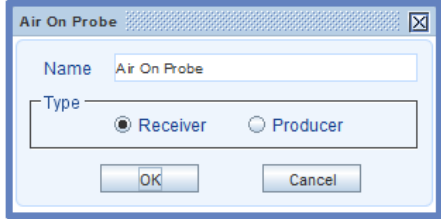
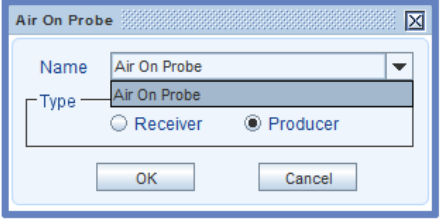
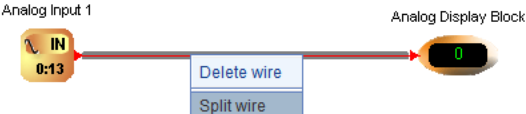
### Shortcut Block

Icon	Properties
	<p>Shortcut blocks can be used throughout the users program to 'de-clutter' the canvas from multiple wires linked across the entire program. While selected, by clicking on the canvas it will place the block. Editing the properties will allow the user to 'bridge' wires between blocks.</p> <p>The below example will outline the basic setup.</p> <div style="text-align: center;">  </div> <div style="display: flex; justify-content: space-around; margin-top: 20px;"> <div style="text-align: center;">  </div> <div style="text-align: center;">  </div> </div> <p><b>Split Wire</b></p> <p>By right clicking on any wire between two blocks the user has the ability to 'Split' a wire. By selecting it, the wire will be 'cut' and two linked shortcut blocks will be created, similar to the example on the right.</p> <div style="text-align: center; margin-top: 20px;">  </div> <div style="text-align: center; margin-top: 20px;">  </div> <p>The name of the shortcuts will be automatically assigned that of the block the wire is coming from.</p>



Please ensure all power is switched off before installing or maintaining this product.

## Settings Block

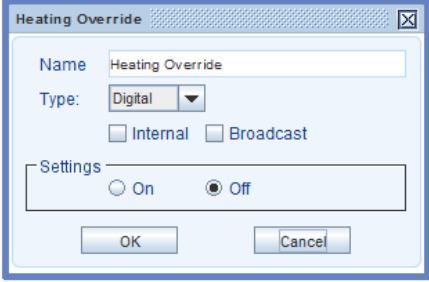
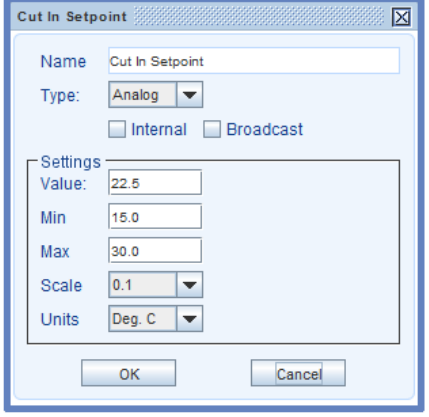
Icon	Properties
	<p>Setting blocks can be created to give permanent values or allow end users to set specific values when the program is in use. For example changeable set points in an 'Air Conditioning Application'.</p> <p>Setting blocks can be made 'Digital' or 'Analogue', each providing properties to set;</p> <div data-bbox="395 450 826 786"> <p>Heating Override</p>  </div> <p><b>Digital</b></p> <p>When set to 'Digital' the setting icon will automatically set itself to be blue, making it easier to recognise it as a digital setting block as oppose to analogue (yellow). Within the properties box, along with the type, the block can be named and the desired 'default' value is selectable.</p> <p><b>Internal Option:</b> Dictates whether the setting block will be visible on the devices web page and/ or DM device list. If checked, the settings block is only set-able within the TDB Editor.</p> <p><b>Broadcast Option:</b> Allows the parameter to be broadcast over the IP network, picked up by other TDB devices.</p> <p><b>Analogue</b></p> <p>While set for 'Analogue' the settings shown on the left will be visible.</p> <p>The Internal and Broadcast options are identical to that above.</p> <p>The example shows a setting block configured as 'Cut In Setpoint, given a default value of 22.5°C. The block can be configured from the I/O list of the program and can be set no higher than 30.0°C and no lower than 15.0°C.</p> <div data-bbox="932 837 1362 1308"> <p>Cut In Setpoint</p>  </div>

## Online Mode

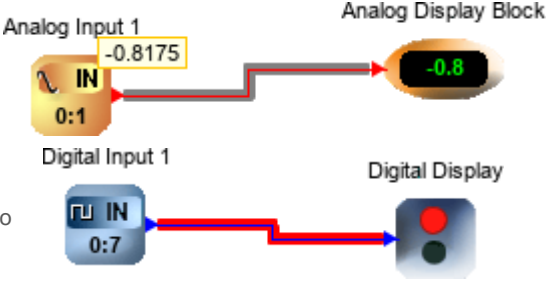
Icon	Properties
	<p>To use 'Online mode' within the editor it must be connected (via IP) directly to the TDB device. To utilise the online mode the TDB program must be identical to that within the device it is to be connected to.</p> <p><b>Important:</b> Following any amendments to the plc it must be saved and/ or uploaded to the connected device.</p> <p>With the program saved/ uploaded to the TDB device, the icon can be clicked to 'link' the editor and device so that the user can witness real time updates and readings. Within the pop up window, enter the device's IP address to connect. While 'Online' the user can roll the pointer over a block's 'end point' to view the current reading of that block, digital wires will also illuminate indicating their state.</p> <div data-bbox="831 1435 1382 1715">  </div>



Please ensure all power is switched off before installing or maintaining this product.

## Run Simulation

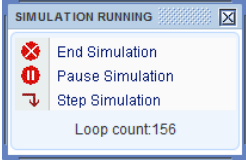
Icon	Properties
	<p>Before uploading any PLC program it is recommend the user runs a simulation and test all sections of the program to confirm the expected result and control. While in Simulation mode, the editing facility of the Editor is temporarily removed. Certain blocks can be 'clicked' on so the user can input values to recreate the environment it will be in.</p> <p>Notice within I/O blocks there will be 'Simulation Settings'. These values will be used while the program is in this mode. Additionally, the user will notice the 'Simulation Running' window.</p> <div style="text-align: center;"> </div> <div style="text-align: right; margin-top: 10px;">  </div>



Please ensure all power is switched off before installing or maintaining this product.

## I/O Objects & Properties

### Analogue In

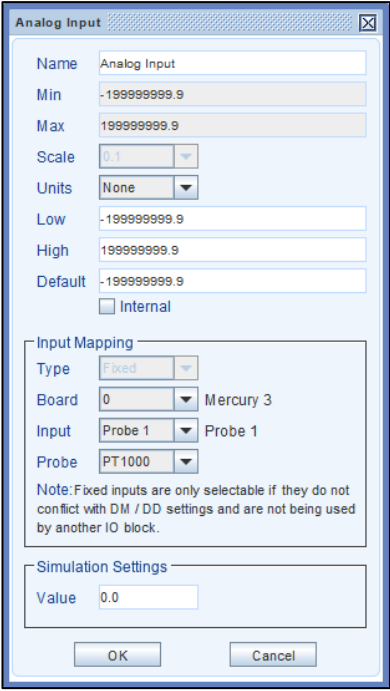
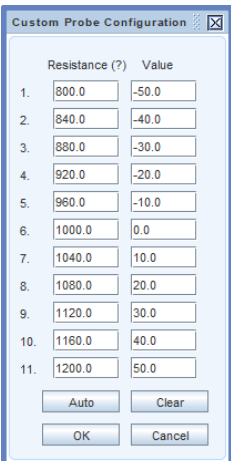
Icon	Properties
	<p>Each Analogue Input block has similar settings, outlined by;</p> <div style="border: 1px solid #ccc; padding: 5px; margin-bottom: 10px;">  </div> <p><b>Name:</b> Provide a unique alias for the input.</p> <p><b>Min/ Max:</b> When 'units' is selected, the values self-populate. If the input value goes out with these bounds, the value read on the IO list will be '??????'.</p> <p><b>Scale:</b> When 'units' is selected, the scale self-populates.</p> <p><b>Units:</b> Depending on the measurement, select the appropriate unit.</p> <p><b>Low/ High:</b> These are adjustable limits the user can set. If the input's value goes out with them, the value will automatically take the 'Default' value.</p> <p><b>Default:</b> Static value the input will display if the input goes out with the Low/ High limits.</p> <p><b>Internal:</b> Check the 'Internal' field if the input is not to be shown on the device's IO list.</p> <p><b>Simulation Settings:</b> Value the input will have when running a simulation. <b>Note:</b> this can be altered during the running of the simulation.</p> <p><b>Input Mapping</b></p> <p><b>On the Intuitive Mercury, the 'Type' is always 'Fixed'.</b></p> <p>Fixed Inputs are those that are mapped to a physical Input on the Intuitive Mercury hardware platform the PLC app is being installed on to.</p> <p><b>Board:</b> The board refers to the hardware the input will be mapped to. This will either be '0' for the Intuitive Mercury or '1' if there has been a daughter card configured from within the <a href="#">Program Settings</a> menu.</p> <p><b>Input:</b> Select which physical connection on the device the input is to be mapped to.</p> <p><b>Probe:</b> Choose the probe type that will be connected to the unit; PT1000, 2K, 470R, 700R, 3K, 2K25, 100K, 5K, 6K, 10K, 10K Type2, Raw* or Custom**.</p> <p>*Raw: If Probe type 'Raw' is selected then no resistance to temperature conversion will take place, value displayed will be the probe's resistance value in ohms.</p> <p>**Custom: If an analogue input has been configured to use a Custom profile then to select and use one of the pre-set probe types e.g. PT1000, the analogue input must be deleted and reinserted into the program.</p> <div style="border: 1px solid #ccc; padding: 5px; margin-top: 10px;">  </div> <p>Continued...</p> <p><b>Define:</b> If selecting either a 'Custom' probe type or a Universal Input, the user must configure the conversion table manually. A resistance conversion table (for custom probe type) is shown on the left.</p> <p>The first column's values (resistance/ mA/ V) must be entered in ascending order. The corresponding value (right column) must then be entered.</p> <p>For convenience there are 'Auto' and 'Clear' buttons to aid in the entering of the details. Pressing 'Clear' will clear the complete</p>



Please ensure all power is switched off before installing or maintaining this product.

table of all values. To utilise the 'Auto' calculation feature a minimum of 2 values must be entered. Then pressing 'Auto' will automatically calculate the remaining fields, as per below example;

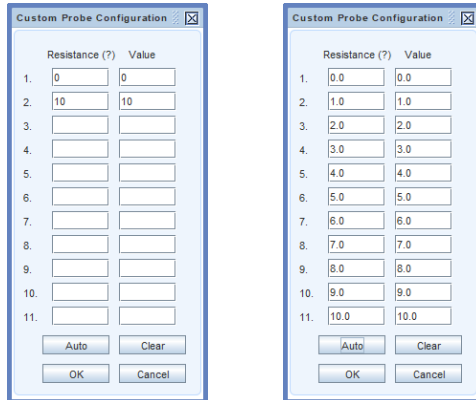

## Analogue Out

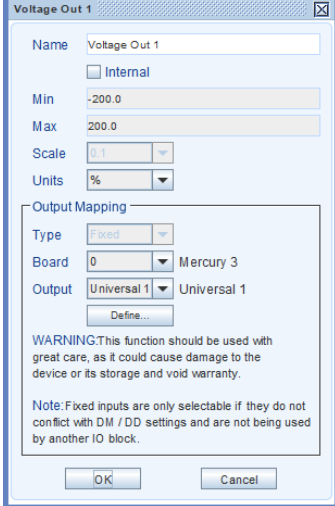
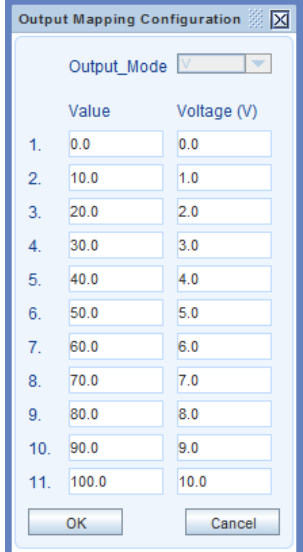
Icon	Properties
	<p>Similar to the Analogue in, the general properties can first be set (Name, Min, Max etc.).</p> <p><b>On the Intuitive Mercury, the 'Type' is always 'Fixed'.</b></p> <p><b>Output Mapping</b></p> <p>The properties box will show the option of 'Board', 'Output' and has the 'Define' option.</p> <p><b>Board:</b> The board refers to the hardware the output will be mapped to. This will either be '0' for the Intuitive Mercury or '1' if there has been a daughter card configured from within the <a href="#">Program Settings</a> menu.</p> <p><b>Output:</b> Select the Output position on the selected board.</p> <p>In the example on the right the Universal Output No1 in the Intuitive Mercury has been selected. The Analogue output then needs to be <b>defined</b>;</p> <p><b>Output Mapping Configuration</b></p> <p>If the Universal I/O from the Intuitive Mercury has been selected, the Output Mode can be selected (mA/V).</p> <p>If the Output of a daughter card is to be used the Output Mode is automatically selected.</p> <p>The user must then define an input value to the block and the associated output value. There are 11 definable points, and between points there is a linear interpolation (must be ascending).</p> <p>As a default, the configuration will be a linear output with 0-10V (or 4-20mA), scaled to 0-100 units input value.</p>
	<div style="float: right;">  </div> <div style="float: right; margin-top: 20px;">  </div>



Please ensure all power is switched off before installing or maintaining this product.



## Digital In

Icon	Properties
	<p><b>Name:</b> Provide a unique alias for the input.</p> <p><b>Internal:</b> Check the 'Internal' field if the input is not to be shown on the device's IO list.</p> <p><b>Simulation Settings:</b> Value the input will have when running a simulation. <b>Note:</b> this can be altered during the running of the simulation.</p> <p><b>Input Mapping</b></p> <p><b>On the Intuitive Mercury, the 'Type' is always 'Fixed'.</b></p> <p><b>Board:</b> The board refers to the hardware the input will be mapped to. This will either be '0' for the Intuitive Mercury or '1' if there has been a daughter card configured from within the <a href="#">Program Settings</a> menu.</p> <p><b>Input:</b> Select which input is to be used from the drop-down menu.</p> <p><b>Define:</b> If a 'Probe Input' is selected, the define button will appear and allow the user to manually enter the resistance level of which will trigger an 'On' signal. See below.</p> <div data-bbox="970 416 1366 864" style="border: 1px solid blue; padding: 5px;"> <p><b>Digital Input</b></p> <p>Name: Digital Input</p> <p><input type="checkbox"/> Internal</p> <p>Input Mapping</p> <p>Type: Fixed</p> <p>Board: 0 Mercury 3</p> <p>Input: Probe 1 Probe 1</p> <p>Define...</p> <p><small>Note: Fixed inputs are only selectable if they do not conflict with DM / DD settings and are not being used by another IO block.</small></p> <p>Simulation Settings</p> <p><input type="radio"/> On <input checked="" type="radio"/> Off</p> <p>OK Cancel</p> </div> <div data-bbox="895 958 1378 1216" style="border: 1px solid blue; padding: 5px;"> <p><b>Digital Configuration</b></p> <p>Enter the resistance value that will trigger a digital "On" signal.</p> <p>Setup</p> <p>Threshold (?): 1000.0</p> <p>OK Cancel</p> </div>



Please ensure all power is switched off before installing or maintaining this product.

## Digital Out

Icon	Properties
	<p><b>Name:</b> Provide a unique alias for the input.</p> <p><b>Internal:</b> Check the 'Internal' field if the input is not to be shown on the device's IO list.</p> <p><b>Invert Output:</b> Tick the invert output box to invert the relay operation.</p> <p><b>On the Intuitive Mercury, the 'Type' is always 'Fixed'.</b></p> <p><b>Board:</b> The board refers to the hardware the input will be mapped to. This will either be '0' for the Intuitive Mercury or '1' if there has been a daughter card configured from within the <a href="#">Program Settings</a> menu.</p> <p><b>Output:</b> Select which output is to be used from the drop-down menu.</p>

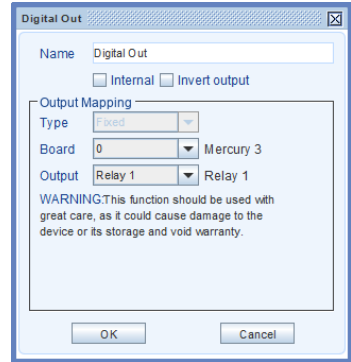

## Network Analogue In

Icon	Properties
	<p>Network Analogue inputs can be used to map analogue values from a Data Builder program running on a Data Manager to an Intuitive Mercury TDB controller</p> <p>Please see the following section that outlines the setup process. – <a href="#">Network Analogue Inputs</a></p>

## Network Digital In

Icon	Properties
	<p>Network digital inputs can be used to map digital values from a GP Timer or a Data Builder program, running on a Data Manager, to an Intuitive Mercury TDB controller</p> <p>Please see the following section that outlines the setup process. – <a href="#">Network Digital Inputs</a></p>



Please ensure all power is switched off before installing or maintaining this product.

### GP Timer 3 Block

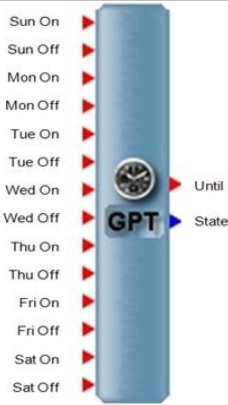
Icon	Properties
	<p>The GP Timer 3 Block provides a single on and off per day. Use a setting block to define an on time and off time for each day.</p> <p>The block has a digital output to show the current timer state. This is 'on' when the timer is in the 'on' state and off when the timer is in the off state.</p> <p><b>Note:</b> the time from the analogue output is not relevant for use by the end user.</p> <p>The block utilises the RTC in the controller.</p>

### Defrost Signal

Icon	Properties
	<p>The block allows for commands from the Defrost Timer schedules in a Data Manager to be mapped into the TDB program. Please consult the Data Manager User guide to see how to configure a defrost channel.</p> <p>The output of this block will show the following (please note the command sent to the output of this block is only present momentarily);</p> <p>0 = No defrost, defrost timer channel in the off period.                  1 = Defrost, defrost timer channel in the on period.                  3 = Defrost termination, used with Defrost Hold.</p> <p>It is advisable to configure a local schedule in the TDB program in the event of a communication loss between the controller and the Data Manager.</p>

### State Block

Icon	Properties
	<p>The Control State block allows the user to define the current status of a TDB program.</p> <p>Varying the analogue value fed into the block allows the user to select the current state.</p> <p>In the example to the right, Tag 4 is set to Inhibit, if the number '4' is fed into the control state block then the state would become Inhibit.</p> <p>When viewing the controller details, Override would be shown in the value column next to control state. If '0' is fed in the state would show Normal and the value would be Normal.</p> <p>The Tag option allows the user to define what is shown in the Status column, found on the Device List of a Data Manager, when in a given state. This allows the Status column to indicate when the TDB controller is in 'Defrost' or 'Alarm' etc.</p>

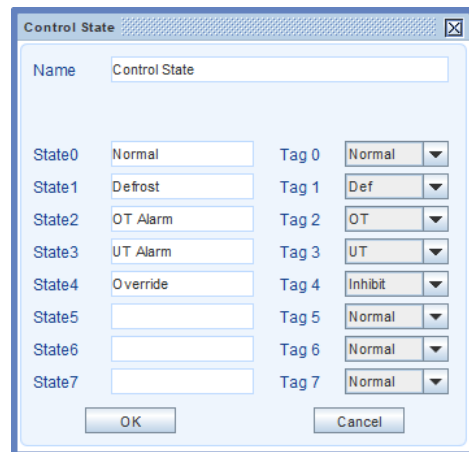

Please ensure all power is switched off before installing or maintaining this product.

## Humidistat Display



Display Input  
 Red LED Input  
 Amber LED Input  
 Green LED Input  
 Mode 1

Enter key Output  
 Hash key Output  
 Up key Output  
 Down key Output  
 Temperature Output  
 Humidity Output

RDM Part Number PR0445

The inputs are as follows;

**Display Input:** Enter analogue value to be shown on the screen.

**LED inputs:** Switch the LED's on the display on and off by changing the input.

**Mode 1:** Not Used in Intuitive Mercury Host.

Clicking on the properties of the block will display the menu to the right.

The display block can be aliased.

As the display monitors both Temperature and Humidity the values can be aliased. These inputs will appear in the controllers IO list.

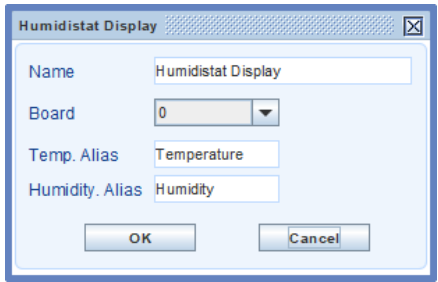

## Humidistat 2 Display

HVAC / Fridge

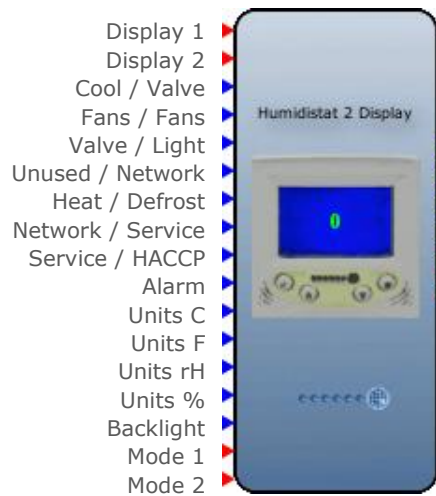

Display 1  
 Display 2  
 Cool / Valve  
 Fans / Fans  
 Valve / Light  
 Unused / Network  
 Heat / Defrost  
 Network / Service  
 Service / HACCP  
 Alarm  
 Units C  
 Units F  
 Units rH  
 Units %  
 Backlight  
 Mode 1  
 Mode 2

Enter key Output  
 Hash key Output  
 Up key Output  
 Down key Output  
 Temperature Output  
 Humidity Output

RDM Part Number PR0445-LCD

The Humidistat 2 display comes in two different hardware variants; **Fridge** or **HVAC**. Therefore within the display block properties (below), the user must define which 'Type' is being used. If the hardware and the selected type is mismatched, the functions will not work. **Note:** changing the type will dictate the input aliases as listed above.















The inputs are as follows;

**Display 1/2 Inputs:** Enter analogue value to be shown on the screen – Top and Bottom sections.

**Digital Inputs:** Each digital input can be used to enable individual icons / symbols within the LCD. Depending on the hardware/ type set, will alter the associated symbols.



Please ensure all power is switched off before installing or maintaining this product.

Cool / Valve			Service / HACCP		<b>HACCP</b>  <b>oC</b> <b>oF</b> <b>RH</b> <b>%</b>
Fans			Alarm		
Valve / Light			Units C		
Unused / Network			Units F		
Heat / Defrost			Units rH		
Network / Service			Units %		

**Backlight** – Switches the backlight (blue) of the LCD on/ off. **Note:** the icons and characters will still be displayed regardless of backlight state.

**Mode 1/ 2 Inputs** – Not Used in Intuitive Mercury Host.

Clicking on the properties of the block will display the menu to the right.

**Name:** The display block can be aliased.  
**Type:** Select Type as outlined above (HVAC / Fridge).  
**Aliases:** The display monitors both Temperature and Humidity, these values can be aliased. These inputs will appear in the controllers IO list.



Please ensure all power is switched off before installing or maintaining this product.

## Logic Blocks

### And blocks

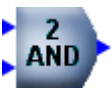
	<b>A</b>	<b>B</b>	<b>Output</b>
	Off	Off	Off
	Off	On	Off
	On	On	On

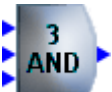

	<b>A</b>	<b>B</b>	<b>C</b>	<b>Output</b>
	Off	Off	Off	Off
	Off	Off	On	Off
	Off	On	Off	Off
	Off	On	On	Off
	On	Off	Off	Off
	On	Off	On	Off
	On	On	Off	Off

  

	<b>A</b>	<b>B</b>	<b>C</b>	<b>D</b>	<b>Output</b>
	Off	Off	Off	Off	Off
	Off	Off	Off	On	Off
	Off	Off	On	Off	Off
	Off	Off	On	On	Off
	Off	On	Off	Off	Off
	Off	On	Off	On	Off
	Off	On	On	Off	Off
	Off	On	On	On	Off
	On	Off	Off	Off	Off
	On	Off	Off	On	Off
	On	Off	On	Off	Off
	On	Off	On	On	Off
	On	On	Off	Off	Off
	On	On	Off	On	Off

### OR Blocks

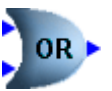
	<b>A</b>	<b>B</b>	<b>Output</b>
	Off	Off	Off
	Off	On	On
	On	On	On

  

	<b>A</b>	<b>B</b>	<b>C</b>	<b>Output</b>
	Off	Off	Off	Off
	Off	Off	On	On
	Off	On	Off	On
	Off	On	On	On
	On	Off	Off	On
	On	Off	On	On
	On	On	Off	On

  

	<b>A</b>	<b>B</b>	<b>C</b>	<b>D</b>	<b>Output</b>
	Off	Off	Off	Off	Off
	Off	Off	Off	On	On
	Off	Off	On	Off	On
	Off	Off	On	On	On
	Off	On	Off	Off	On
	Off	On	Off	On	On
	Off	On	On	Off	On
	Off	On	On	On	On
	On	Off	Off	Off	On
	On	Off	Off	On	On
	On	Off	On	Off	On
	On	Off	On	On	On
	On	On	Off	Off	On
	On	On	Off	On	On

### Not Block & Exclusive OR Block

	<b>A</b>	<b>Output</b>
	Off	On





	<b>A</b>	<b>B</b>	<b>Output</b>
	Off	Off	Off
	Off	On	On
	On	On	Off

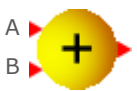

Please ensure all power is switched off before installing or maintaining this product.

## Mathematical Blocks

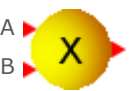
(+, -, x, ÷ blocks)

 Output = A + B	 Output = A - B	 Output = A x B	 Output = A ÷ B
---	---	--	---

## Absolute (abs) Block

Icon	Properties
	Output = A absolute  The absolute block converts a value entered at 'A' to an absolute value, e.g. a negative value becomes a positive.



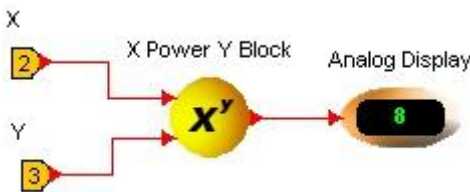

## X to the Power of Y (x<sup>y</sup>)

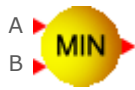
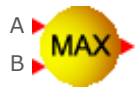
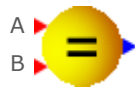
Icon	Properties
	Output=A <sup>B</sup>  An X <sup>Y</sup> block gives a value of X to the power of Y, in other words X multiplied by itself Y amount of times. In the example below, 2 to the power of 3 (or 2 cubed) equals 8. <div style="text-align: center; margin-top: 10px;">  </div>

## Min, Max, Equals blocks

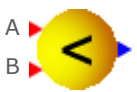
 If A < B Output = A If B < A Output = B	 If A > B Output = A If B > A Output = B	 If A = B Output = on If A ≠ B Output = off
---	---	--



## <, >, ≤, ≥ blocks

 If A < B Output = On	 If A > B Output = On	 If A ≤ B Output = On	 If A ≥ B Output = On
--	--	--	--

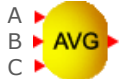

Please ensure all power is switched off before installing or maintaining this product.

### Average & Limit blocks

 <p>Output = <math>(A + B) \div 2</math></p>	 <p>Output = <math>(A + B + C) \div 3</math></p>	 <p>Output = <math>(A + B + C + D) \div 4</math></p>	 <p>If <math>A &gt; B</math> Output = B If <math>A &lt; C</math> Output = C If <math>C &lt; A &lt; B</math> Output = A</p>
---	---	---	---

### Range

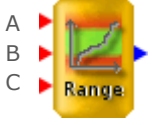
Icon	Properties
	<p><b>Input A:</b> Analogue Value <b>Input B:</b> Max Limit <b>Input C:</b> Min Limit</p> <p>Digital output goes off when the Analogue value is out with the Max and Min limits.</p>

### Min, Max, Avg. Block

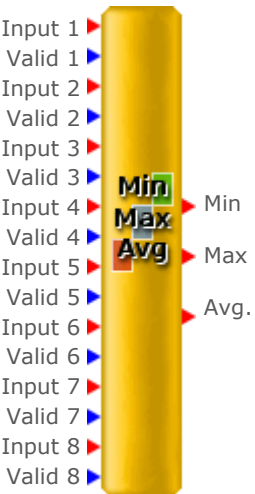
Icon	Properties
	<p><b>Input 1-8:</b> Analogue Values</p> <p><b>Valid 1-8:</b> If the valid input is present the corresponding analogue input value will be used by the block.</p> <p><b>Min:</b> The minimum value is outputted. <b>Max:</b> The maximum value is outputted <b>Avg:</b> The average value is outputted.</p>



Please ensure all power is switched off before installing or maintaining this product.

## Filter

Icon	Properties
	<p>The filter block can be used to apply a dampening factor to the analogue input.</p> <p><b>Rate</b> How often the calculation occurs (in seconds).</p> <p><b>T Const.</b> The time constant used (in seconds).</p> <p><b>Min Value</b> Minimum value expected.</p> <p><b>Max Value</b> Maximum value expected.</p> <p><b>Operation</b> When an analogue value 'X' enters the block with a t-Const value of, for example 2700 (45min):</p> <p>With an increasing input, it calculates the rate of change for the value X to reach 63.2% of its current value over the 2700 seconds. If the t-Const is increased (from 2700), you are lengthening the time for it to get to the 63.2% point. Thus increasing the dampening factor.</p> <p>With a decreasing input, it works the same as above, only calculates the rate of change to reach 32.8% of its current value.</p> <p>The calculation is carried out every period set in the 'Rate' field.</p> <p>Depending on the input's rate of change will indicate what the 'rate' will need set to. Additionally, depending on the environment and required dampening, the t-Const will need to be adjusted.</p> <div data-bbox="954 302 1364 577" style="border: 1px solid black; padding: 5px; margin-top: 10px;"> <p><b>Filter Block 1</b></p> <p>Name: Filter Block 1</p> <p>Rate (Hz): 10.0</p> <p>t Const: 2700.0</p> <p>Min Value: -3200.0</p> <p>Max Value: 3200.0</p> <p>OK Cancel</p> </div>

## Accumulator Block

Icon	Properties
 <p>Input → Total</p> <p>Reset → Time</p>	<p><b>Input:</b> The accumulator block samples the value at the input and adds it to the running total count, this sample/calculation is fixed and is carried out every second.</p> <p><b>Total:</b> This is the running total. The accumulation process will start as soon as the TDB program is running.</p> <p><b>Time:</b> The time output is in seconds and provides the total elapsed time from last power on or reset.</p> <p><b>Reset:</b> The total value count and time elapsed will be set to zero when the reset input is activated.</p> <p>In the example below, a flow meter with a litres per second analogue output is connected to the input of the accumulator block. Every second, the instantaneous litres per second value is added to the total. The total litres used and the total time, in seconds, is displayed on the right.</p> <div data-bbox="667 1608 1220 1915" style="text-align: center;"> </div>



Please ensure all power is switched off before installing or maintaining this product.

## Algebra

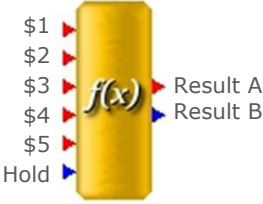
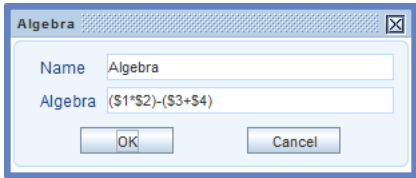
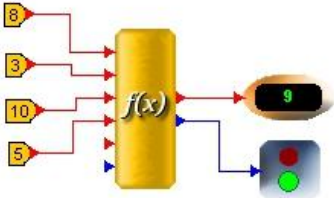
Icon	Properties
 <p>Digital Output 'Result B' will go 'high' for a non 0 result.</p>	<p>This block has 5 variable analogue inputs and will perform advanced calculations.</p> <p>The digital 'Hold' input, when on, will hold the result regardless of the values updating on the analogue inputs.</p> <p>Calculation can be up to 255 characters long. Useable symbols within the equations;</p> <ul style="list-style-type: none"> <li>+ Addition</li> <li>- Subtraction</li> <li>* Multiplication</li> <li>/ Division</li> <li>^ Raised to the power of.</li> </ul> <p>Precedence : ^ , * , / , + , -</p> <p>Brackets can be used to control execution order.</p> <p><b>Rounding;</b></p> <p><b>round (x):</b> Value is rounded up or down to the nearest whole number.  <b>ceil (x):</b> Value is rounded up to the nearest whole number.  <b>floor (x):</b> Value is rounded down to the nearest whole number.</p> <p>The block will also perform trigonometric and log equations;</p> <p><b>sin (x):</b> Sine of x (Argument in radians)  <b>cos (x):</b> Cosine of x (Argument in radians)  <b>tan (x):</b> Tangent of x (Argument in radians)  <b>asin (x):</b> Arc sine of x (Argument in radians)  <b>acos (x):</b> Arc cosine of x (Argument in radians)  <b>atan (x):</b> Arc tangent of x (Argument in radians)  <b>sqrt (x):</b> Square root of x  <b>abs (x):</b> Absolute value of x  <b>exp (x):</b> E raised to the power of x  <b>ln (x):</b> Natural (base e) log of x  <b>log (x):</b> Base 10 log of x  <b>rad (x):</b> Convert x degrees to radians  <b>deg (x):</b> Convert x radians to degrees</p> <p><b>Note 1:</b> Spaces in a formula are ignored</p> <p><b>Note 2:</b> The floating point calculation used in the Algebra block, within the TDB platform, supports 16 significant digits.</p> <p>In the simple example below:</p> <p style="padding-left: 40px;">Input \$1=8, \$2=3, \$3=10 and \$4=5.                  The equation is (\$1 x \$2) - (\$3 + \$4) or (8 x 3) - (10 + 5)</p> <p>So the analogue result 'A' will be 9. Digital result 'B' will be ON as there is a non-zero result.</p> <div style="display: flex; justify-content: space-around; align-items: center;"> <div data-bbox="513 1722 930 1899">  </div> <div data-bbox="986 1686 1321 1883">  </div> </div>



Please ensure all power is switched off before installing or maintaining this product.

## Time Blocks

### Delay On Timer

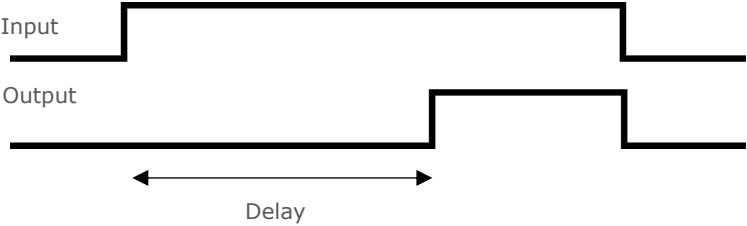
Icon	Properties
Input Reset Delay 	 <p>When the input is activated, the output will remain 'off' until the delay period has elapsed. The output will then remain 'on' until the input goes 'off' or if the reset is activated.</p>

### Pulse Timer

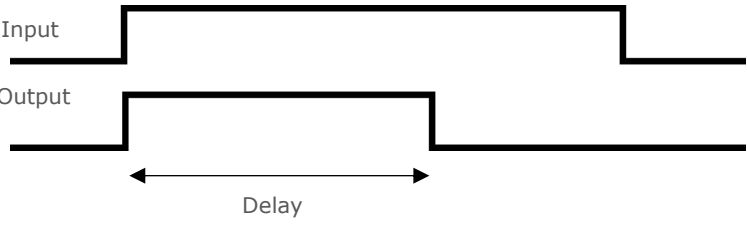
Icon	Properties
Input Reset Delay 	 <p>When the input is activated the Output will turn on. The output will return to the 'off' state when the delay (pulse time) expires or the input is removed before the delay time has expired or the reset is activated before the delay time has expired.</p>

### Heartbeat

Icon	Properties
Period Sync 	<p>A momentary on pulse is generated on the output at the beginning of every time period as determined by the value set in period. The period value is in seconds. The sync input will reset the period timer back to zero when activated allowing the pulse to become synchronised with another timed function.</p> <p>The Heartbeat Block would typically be used to trigger an event at a regular interval, for example, it could be used to activate an Analogue Store to store a temperature every minute.</p> <p>The shortest 'Period Value' that can be entered is 0.2 of a second.</p> <p><b>Note:</b> The use of an SR latch block may be required.</p>

### Run On

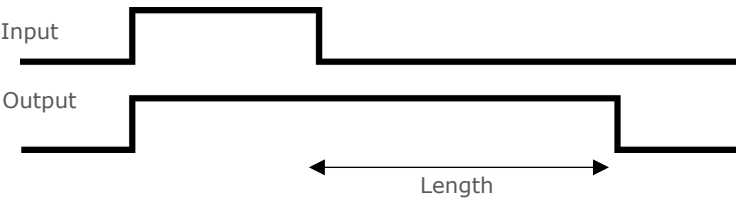
Icon	Properties
Input Length 	 <p>When the input is activated the output will turn 'on' and remain 'on' until the length time period has elapsed.</p>



Please ensure all power is switched off before installing or maintaining this product.

### Run Hours Block

Icon	Properties
 <p>Input A: Input Input B: Reset</p>	<p>The output displays the total number of hours that the input is active. The output is shown to one decimal place. The output will go to zero when the reset input is active (On). The hour count is stored in the device's memory on the hour and half past the hour. The maximum hour count is 596,680 (which equates to 68 years).</p>

### Change Over

Icon	Properties
	<p><b>Input:</b> Demand required. Either Enable 1 or 2 will be turned on when this input is activated and will go off when the input is deactivated. The output activated will vary depending on whether or not the Swap input has been enabled.</p> <p><b>Swap:</b> When activated the Enable output current operating will be turned off and the alternative Enable output turned on (Proof dependant). If the Swap input has never been activated then only Enable 1 will be activated by the Input.</p> <p><b>Proof 1 &amp; 2:</b> If used a proof signal must be returned when the associated Enable output is activated. If the proof is returned within the Delay parameter time the Enable output stays on, if not the associated Enable output is turned off and the alternative Enable output is turned on.</p> <p><b>Note:</b> If Proof inputs are not required then a digital setting block set to 'On' must be used to bypass the Proof input(s).</p> <p><b>Delay:</b> Time delay associated to Proof 1&amp;2</p> <p><b>Enable 1:</b> Digital Output.</p> <p><b>Fail 1:</b> Activated if Proof 1 is not returned within the 'Delay' time after Enable 1 is turned on.</p> <p><b>Enable 2:</b> Digital Output.</p> <p><b>Fail 2:</b> Activated if Proof 2 is not returned within the 'Delay' time after Enable 2 is turned on.</p>

### Match Date

Icon	Properties
	<p>Match Date output goes high when the date in the controller hardware RTC matches the day, month and year defined.</p> <p>Output stays on for 24 hours until the date changes. Not defining the year field allows the block to match the day &amp; month regardless of the year. Not defining the month and year fields allows the block to match the day regardless of the month &amp; year.</p> <p>Uses the controllers current time and date.</p>



Please ensure all power is switched off before installing or maintaining this product.

### Date Time Block

Icon	Properties
	<p>Seconds Minutes Hours Day Month Year DST Since Midnight</p> <p>It uses the TDB device's Time and date. It separates the Time &amp; Date and outputs them as analogue outputs.</p> <p>Splits it into Seconds, Minutes and Hours.</p> <p>Splits it into Day, Month and Year.</p> <p>Output will come on when daylight saving time is on</p> <p>Since Midnight: Output counts up the seconds from midnight. Resets back to 0 at midnight and starts counting up again.</p>

### Summer or winter

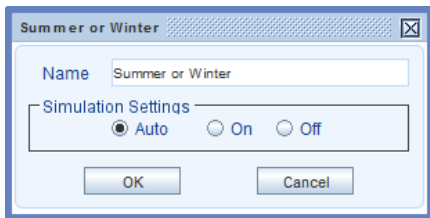
Icon	Properties
	<p>This block performs an automatic summer/winter (BST/GMT) time change. Block Name can be changed if required.</p> 

### Daylight Block

Icon	Properties
<p>Latitude Longitude Morning Offset Evening Offset</p>  <p>Daytime Twilight</p>	<p>The Daylight block can be used to provide an indication of daylight and twilight hours for a given geographical location. Note the information provided by this block should be used as a guide only.</p> <p><b>Latitude:</b> Enter the current Latitude coordinate of the TDB device e.g. 55.856742.</p> <p><b>Longitude:</b> Enter the current Longitude coordinate of the TDB device e.g. -4.353971.</p> <p><b>Morning Offset:</b> Allows for a positive or negative offset to be added to the morning on time for the Daytime and Twilight outputs. A positive offset will advance the Daytime and Twilight on time. A negative offset will delay the Daytime and Twilight on time.</p> <p><b>Evening Offset:</b> Allows for a positive or negative offset to be added to the evening off time for the Daytime and Twilight outputs. A positive offset will delay the Daytime and Twilight off time. A negative offset will advance the Daytime and Twilight off time.</p> <p><b>Daytime:</b> The Daytime output will turn on at sunrise and off at sunset based on the Latitude and Longitude settings entered.</p> <p><b>Twilight:</b> The Twilight output will turn on when Twilight begins shortly before sunrise and off when Twilight ends shortly after sunset.</p> <p>Any offset should be added in Seconds, use the unit type 'secs'. To achieve a negative offset enter a negative number, for example -900 would equate to 15 minutes.</p>



Please ensure all power is switched off before installing or maintaining this product.

### Time Block

Icon	Properties
	<p>Block Name can be changed.</p> <p>Output turns on at the 'start time' and turns off at the 'stop time'.</p> <p>Both time inputs can work to a 'second' resolution.</p> <div style="border: 1px solid #ccc; padding: 5px; width: fit-content; margin-top: 10px;"> <p><b>Time Block</b> <span style="float: right;">✕</span></p> <p>Name <input type="text" value="Time Block"/></p> <p style="text-align: center;"><input type="button" value="OK"/> <input type="button" value="Cancel"/></p> </div>

### Schedule

Icon	Properties
	<p>The Schedule block can be used to signal a number of events every specified number of days. The TDB Controller's real time clock is used to determine the current time.</p> <p><b>Start:</b> Enter the initial start time. The Output will activate when this time is reached. Note the output is only active for 1 second.</p> <p><b>End:</b> Enter the last scheduled start time. The Output will activate when this time is reached. Note the output is only active for 1 second.</p> <p><b>No. Per Day:</b> Enter the number of events required per day. If more than two events occur in a single day then the total number of events will be evenly spaced including the Start and End times. Please see example below.</p> <div style="margin-left: 20px;"> <p>Start                    13:00</p> <p>End                      16:00</p> <p>No. Per Day            4</p> </div> <p>In the above example the output would be active at 13:00, 14:00, 15:00 and 16:00 hours. Note if only 1 event per day is entered then the output will trigger on the 'Start' parameter</p> <p><b>Days:</b> Enter the frequency of the events in days. For example if the 'Number Per Day' is set to 2 and the 'Days' parameter is set to 3 then every 3 days the output will be active twice. Once at the entered Start time and again at the End time. Note the schedule takes effect from the last TDB program save. Set to 1 if you wish the schedule to occur every day.</p> <p>Start and End time can span midnight e.g. Start 22:00 End 03:00</p>

### Day of Week Block

Icon	Properties
	<p>Day No.    ut = 0 = Sunday                  Output = 1 = Monday                  Output = 2 = Tuesday                  Output = 3 = Wednesday                  Output = 4 = Thursday                  Output = 5 = Friday                  Output = 6 = Saturday</p> <div style="border: 1px solid #ccc; padding: 5px; width: fit-content; margin-top: 10px;"> <p><b>Day Of Week</b> <span style="float: right;">✕</span></p> <p>Name <input type="text" value="Day Of Week"/></p> <p style="text-align: center;"><input type="button" value="OK"/> <input type="button" value="Cancel"/></p> </div>



Please ensure all power is switched off before installing or maintaining this product.

## Functional Blocks

### Alarm block

	<p>The alarm block is used to indicate an alarm; it's activated by the switch input and can have an alarm delay assigned by using a setting block on the delay input. The alarm can have an 'index' type assigned by editing the properties box.</p> <p><b>Note:</b> There can be a maximum of 20 Alarm Blocks in a program.</p>
---	--

### Analogue Switch

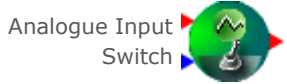
	<p>An analogue value can be switched off using the switch input.</p>
---	--

### Analogue Store

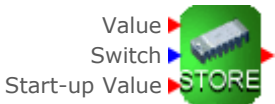
	<p>Initially the output is at the start-up value. Analogue values can be stored by turning the switch on then off, the output retains the input value at the time the switch is turned off.</p> <p><b>Note:</b> The Output of the Analog Store is NOT stored on a reset.</p> <p><b>Note:</b> If more than one Analogue Store is being used then they must each have unique aliases. I.e. Analogue Store 1, Analogue Store 2 etc.</p>
--	--

### Pulse Counter

	<p>The output increments and decrements in accordance with the up and down inputs. The output will go to zero when the reset input is active (On).</p> <p><b>Note:</b> The current count is NOT saved to the Mercury TDB controller memory on the hour and half past the hour and is NOT store on a reset.</p> <p><b>Note:</b> If more than one counter is being used then they must each have unique aliases. I.e. Pulse Counter 1, Pulse Counter 2 etc.</p>
---	---

### D-Latch

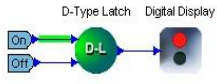
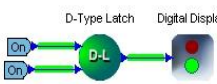
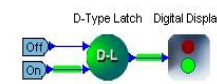
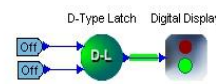
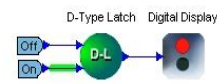
	<p>The 'D' digital input value is clocked through to the output on each rising edge of the clock input B.</p>			
				
<p>Input (A) is on.</p>	<p>Input (A) is switched through to the output when the clock signal (B) is switched on</p>	<p>Input (A) is removed, output stays on.</p>	<p>Clock (B) is removed, output stays on.</p>	<p>Clock (B) is switched on, Input (A), which is off, is 'clocked' through to the output which now goes off.</p>



Please ensure all power is switched off before installing or maintaining this product.

### SR-Latch

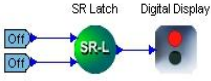
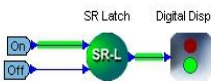
	<p>The output goes on when the 'Set' input goes on, and goes off when the Reset input goes on.</p>
	
<p>Input (A) and reset (B) are both off.</p>	<p>Input (A) is switched on and goes straight through to the output.</p>
	<p>Input (A) is switched off, output remains on.</p>
	<p>Reset (B) is switched on, output is 'reset' and switches off</p>
	<p>Reset (B) is removed.</p>

### Digital Edge Block

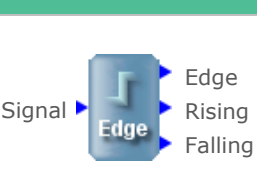
	<p>For each Rising Edge of the input signal the Edge and Rising Outputs will pulse high for 0.1 seconds</p> <p>For each Falling Edge of the Input signal the Edge and Falling Outputs will pulse high for 0.1 seconds.</p>
---	--

### Analogue Edge Block

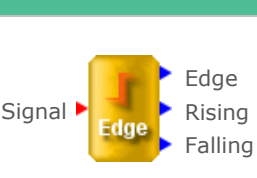
	<p>For each Rising Edge of the input signal the Edge and Rising Outputs will pulse high for 0.1 seconds.</p> <p>For each Falling Edge of the Input signal the Edge and Falling Outputs will pulse high for 0.1 seconds.</p>
---	---



Please ensure all power is switched off before installing or maintaining this product.

## Reverse On/Off

**Reverse On/ Off**



A  
B  
C  
D

Input A: Analogue Input  
Input B: Set Point  
Input C: Diff above SP  
Input D: Diff below SP

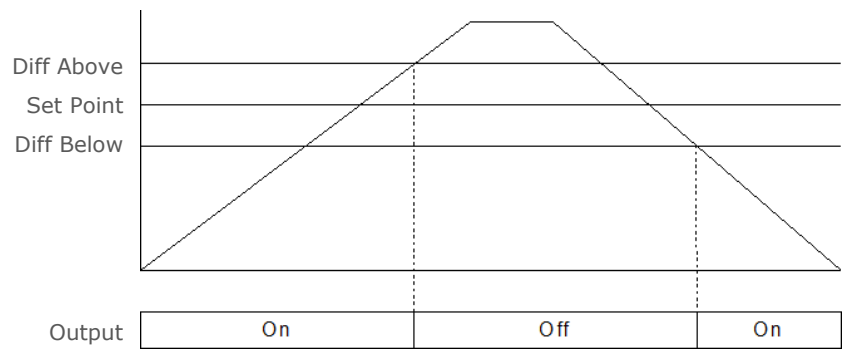

Diff Above

Set Point

Diff Below

Output: On, Off, On

Reverse On/Off blocks are typically used to control a heating function.

As an example, input (A) would be from a temperature probe and setpoint (B) would be the temperature you want to maintain the room at. Differential above setpoint (C) and differential below setpoint (D) are bands either side of the setpoint at which the heating is turned on and off. If there were no differentials (C & D set to zero or not used) then the heating would constantly switch on and off around the set point and cause relay 'chattering'.

As shown in the above graph, when the system is initially switched on the temperature is below the set point minus the diff below, this would cause the output (heating) to be switched on. As the room heats up, the temperature rises above the set point, when the temperature reaches the set point plus the diff above the output (heating) is switched off. The room will gradually cool down, when the temperature falls to the set point minus the diff below, the output (heating) is switched on again.

## Direct On/Off

**Direct On/ Off**



A  
B  
C  
D

Input A: Analogue Input  
Input B: Set Point  
Input C: Diff above SP  
Input D: Diff below SP

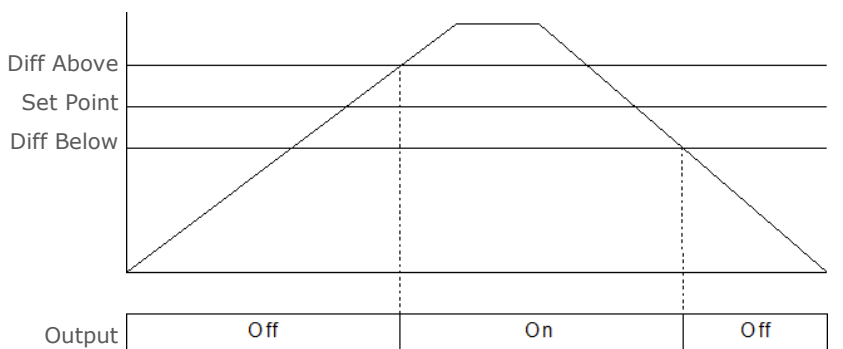

Diff Above

Set Point

Diff Below

Output: Off, On, Off

A Direct On/Off block works in the opposite manner to a Reverse On/Off block and would typically be used to control a cooling function.



Please ensure all power is switched off before installing or maintaining this product.

## Direct PID

<p style="text-align: center;">Direct PID</p>  <p>Input A: Analogue input          Input B: Set Point          Input C: Proportional constant          Input D: Integral          Input E: Derivative</p>	<p>This block performs a PID control function where the set-point, proportional, integral and derivative values can be assigned. It is typically used in a cooling application.</p> <p>A Direct PID block gives a variable output (0-100) depending on the relationship between the analogue input (A) and a set point (B). A Direct PID 2 block has a second output, 'Reverse', which is the inverse value to the Output.</p> <p>If the application requires the output to have limits within the block's 0-100 range then a <a href="#">Limit block</a> can be utilised.</p> <p>Knowledge of PID loop mechanisms is advisable.</p> <p>If the analogue input is increasing rapidly away from the set point then the PID block will increase its output rapidly in an attempt to maintain the set point.</p> <p>If the analogue input is increasing more slowly away from the set point then the analogue output will be proportionally less.</p> <p>A typical application would be to control a condenser fan(s) connected to a variable speed drive with the analogue input coming from a pressure transducer. The speed of the condenser fan(s) would depend on how close the pressure is to the set point and how quickly the pressure is changing.</p> <p>The Proportional constant, Integral and Derivative settings determine how quickly and by how much the output varies in relation to the input. These values require fine tuning and should be used with care.</p>
--	---

## Reverse PID

<p style="text-align: center;">Reverse PID</p>  <p>Input A: Analogue input          Input B: Set Point          Input C: Proportional constant          Input D: Integral          Input E: Derivative</p>	<p>This block performs a Reverse PID control function where the set-point, proportional, integral and derivative values can be assigned. It is typically used in a heating application.</p> <p>If the application requires the output to have limits within the block's 0-100 range then a <a href="#">Limit block</a> can be utilised.</p>
---	---



Please ensure all power is switched off before installing or maintaining this product.

## Levels

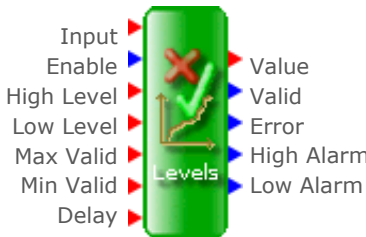
	<p>A Level block is used to monitor an analogue input and check that it is within pre-set parameters.</p> <p>As an example, if the input was a temperature probe then the High Level and Low Levels would be set to initiate an alarm if the temperature went too hot or too cold (subject to the delay). The Max Valid and Min Valid parameters could be set to the limits of the probe scale, an error output would be generated if these limits were exceeded (subject to the delay) which would indicate a probe fault.</p> <p><b>Input:</b> Analogue Signal  <b>Enable:</b> When the input is activated it enables the checking features of the block. Note if disabled the analogue value is still fed through to the 'Value' output.</p> <p>High level, Low Level, Max Valid and Min Valid are settable values.</p> <p><b>Delay:</b> Delay associated to the Error, High and Low alarm digital outputs.</p> <p><b>Value:</b> Value passed from the Input  <b>Valid:</b> The output is active whilst the Input signal is within the Max Valid and Min Valid parameters.  <b>Error:</b> The output is activated when the Input signal is out with the Max/Min Valid parameters.  <b>High Alarm:</b> The output is activated when the Input signal is above the parameter High Level.  <b>Low Alarm:</b> The output is activated when the Input signal is below the parameter Low Level.</p> <p><b>Note:</b> For this block to operate correctly all the inputs must have a value assigned. When the Enable is activated the controller checks all inputs. 'Input', 'High Level', 'Low Level', 'Max Valid', 'Min Valid' and 'Delay'.</p>
---	--



Please ensure all power is switched off before installing or maintaining this product.

## Pressure to Temperature

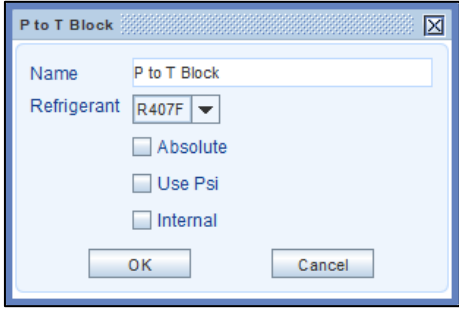
<p>Pressure to Temperature</p>  <p>Pressure → Glide →</p> <p>Current Supported Refrigerants;</p> <p>R12, R13, R13b1, R22, R23, R32, R114, R134a, R142B, R227, R401, R401A, R401B, R401C, R402, R402A, R402B, R404A, R407A, R407B, R407C, R500, R502, R503, R507, R717, R290, R744, R407F, R410A, R449A, R513A.</p>	<p>The pressure to temperature block is used to convert a pressure reading to a temperature based on the refrigerant gas type in use.</p> <p><b>Pressure:</b> Pressure Input.</p> <p><b>Glide:</b> Allows for a linear offset, in degrees Celsius or Fahrenheit, to be subtracted from the output temperature.</p> <p><b>Output:</b> Calculated temperature.</p> <p><b>Absolute:</b> Tick to use Absolute pressure, leave un-ticked for Gauge pressure.</p> <p><b>Use PSI:</b> Pressure input defaults to BAR. Tick if the pressure input to the block is in PSI.</p> <p><b>Internal:</b> Tick to prevent the refrigerant selection appearing in the parameter page.</p> 
---	---

## Comfort Block

<p>Temperature Humidity</p>  <p>Comfort Temperature</p>	<p>This block can use both the Temperature analogue input and the humidity to calculate the apparent temperature using the comfort index shown in <a href="#">appendix 1</a>.</p>
--	---

## Offline Block

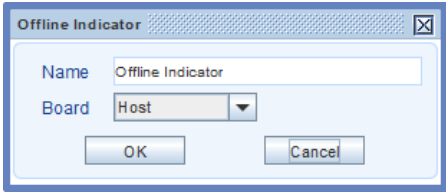
<p>Timeout Offline</p>  <p>Output</p>	<p>Used to monitor comms from the TDB Controller and the Data Manager (if logged on).</p> <p>Block Name can be changed.</p> <p>The 'Board' will always be 'Host'. This refers to the Data Manager.</p> <p>When communications are lost between the TDB controller and the front-end the Output will go 'on' after the input 'Time' has elapsed.</p> 
--	--



Please ensure all power is switched off before installing or maintaining this product.

## Diagnostic blocks

### Analogue Display Block

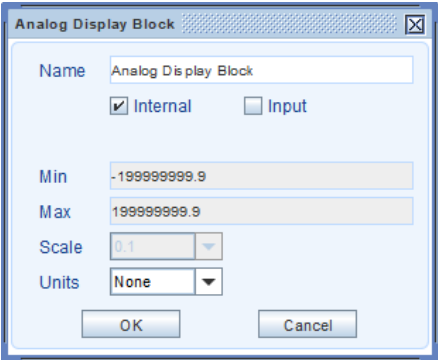
Icon	Properties
	<p>This block gives a visual display of an analogue value within a TDB program using online or simulation mode and has the option of assigning units.</p> <p><b>Internal</b> If the Internal option is ticked then this value will remain within TDB program. If un-ticked, the Analogue display will appear as a value in the output section of the device 'Control Summary'.</p> <p><b>Input</b> If the Input option is ticked the Analogue display will appear as a value in the input section of the IO list.</p> 

### Digital Display Block

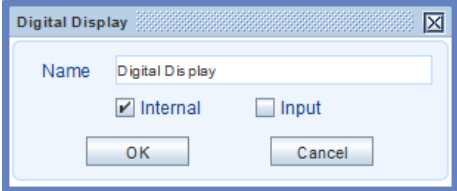
Icon	Properties
	<p>This block gives a visual display of a digital value within a TDB program using online or simulation mode.</p> <p><b>Internal</b> If the Internal option is ticked then this value will remain within TDB program. If un-ticked then the Digital display will appear as a value in the output section of the device 'Control Summary'.</p> <p><b>Input</b> If the Input option is ticked the Digital display will appear as a value in the input section of the IO list.</p> 



Please ensure all power is switched off before installing or maintaining this product.

## Custom Blocks

Custom blocks can be introduced to either create functions which are not available in the standard TDB toolbox or simplify the circuit diagram. **Note:** not all custom blocks will be suitable for all platforms. The blocks used within the custom block needs to be available on the platform intended.

### Creating a new Custom Block

To begin creating a new custom block, open the Editor and click on 'New'. The following options box will be shown;

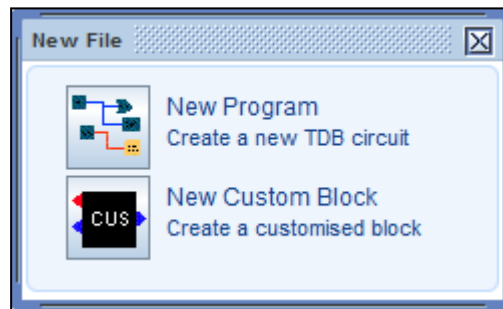

Clicking on 'New Custom Block' will open an 'untitled' tab and offer a blank canvas to begin. From here use the available blocks to create the required custom block. To create inputs and outputs to the block the user must use the 'Tag Block';

Icon	Properties
	<p>The tag block is used to create Inputs and Outputs going to and from the customised block. When selected, clicking on the canvas will place the block.</p> <p>The properties are shown on the right.</p> <p><b>Name:</b> The name given to the Input / Output to the block.</p> <p><b>Signal:</b> Must be either Analogue or digital. <b>Note:</b> the colour of the tags wire will change accordingly.</p> <p><b>Tag Type:</b> Select whether it is to be an input or output to the customised block.</p> <p><b>Simulation settings:</b> The value the I/O will hold during the simulation.</p> <div data-bbox="979 1093 1378 1458" style="border: 1px solid blue; padding: 5px;"> </div> <div data-bbox="555 1525 1136 1693" style="text-align: center;"> </div> <p>When the block is complete. It must be saved before it can be used in other applications. Therefore click on 'Save As' within the editor. The following screen will be shown;</p> <div data-bbox="400 1821 767 2038" style="border: 1px solid blue; padding: 5px;"> </div> <p>The boxes will give you the option to give the block a name and associate a description to it.</p>



Please ensure all power is switched off before installing or maintaining this product.

The next stage is to save the block in a location. For it to be selectable within the Editor the block **must** be saved in the 'custom' folder where the application is installed.

The type of file must be kept as '.blk'.

Give the file a name and click save.

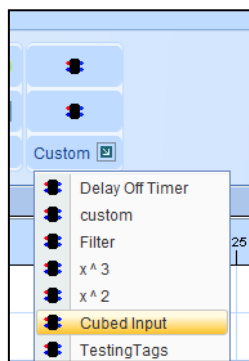
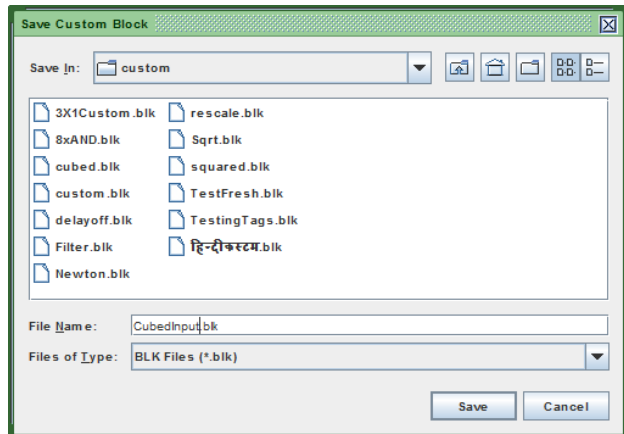

Now, after it has been saved, if the user was to now click on a new program to create a TDB application, within the 'Custom' drop down menu, the newly created block will be visible

Once in use the block will work in whichever application it is placed.

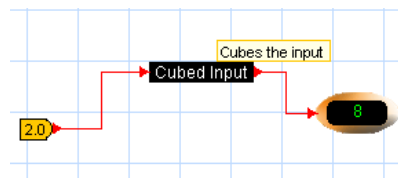

## Find/Replace

### Finding an Item

Right clicking on an unused area of the workspace brings up a sub menu shown on the right, select 'Find/Replace'.

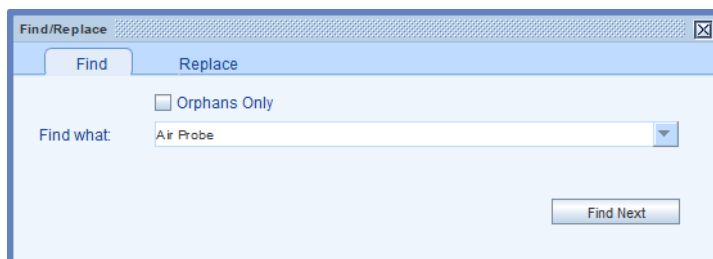
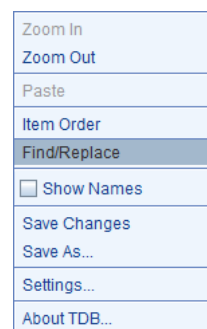

Please ensure all power is switched off before installing or maintaining this product.

Enter the name of the item you want to find, ('Air Probe' in the example) and click 'Find Now'.

The item being searched for will be highlighted in yellow as shown.

If the 'Orphans Only' box is ticked then only items with no wires attached will be found.

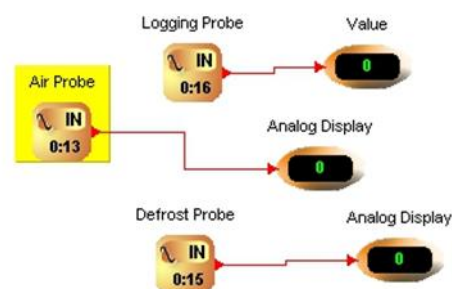

## Replacing an Item

Select the 'Replace' tab and enter the name of the item you want to find. Enter the name you want to replace it with.

Selecting the 'Replace' button will highlight the target in yellow, clicking the 'Replace' button again will change the item's description.

If there are several items with the same name you can replace them all with another name by selecting the 'Replace All' button.

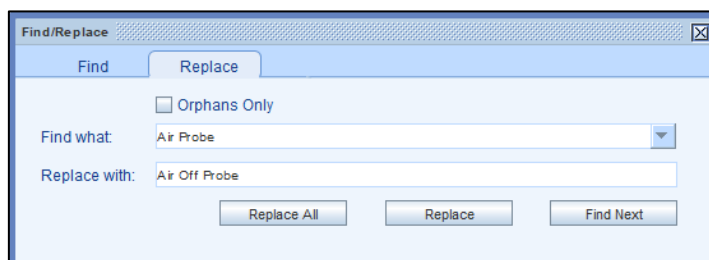

**Note:** Only the item's name will be changed, all other settings will remain the same.

## Show Names

Right click on the workspace and from the sub-menu select 'Show Names'. All TDB blocks will have their names shown above them.



Please ensure all power is switched off before installing or maintaining this product.

## Network Analogue Input

The network analogue input block can be used to receive analogue values sent from a Data Manager. Once the controller is logged onto a Data Manager, Data Builder programs running within the Data Manager can be used to map analogue values to the controller. Please refer to the Desktop Editor User Guide for further details.

### Office Temperature



Output  
Refresh Timeout

Right click on the icon and select 'properties'. The user can define the Input name and assign units.

The 'Device' and 'Value' boxes are not used.

The Input Name has to match the Value box in the Network Analogue Output Block on the DM TDB Editor (See below).

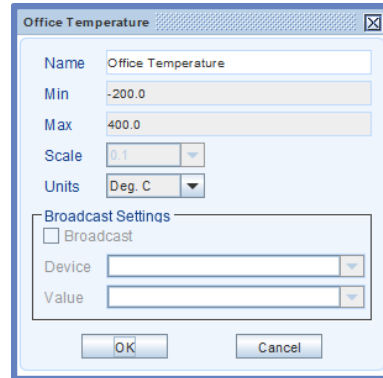

- Output: Outputs the analogue network value at any given time from the network source (Data Manager Data Builder program).
- Refresh Timeout: This output will go true when communications are lost from the network source and the refresh timeout has expired. The refresh timeout value can be changed by right-clicking on the background and selecting [settings](#). **Note:** If communications are lost and the 'Output' is e.g. 'On' then it will remain 'On' until comms are restored. See: [Refresh Timeout](#)
- Broadcast: Feature not currently supported in the Intuitive Mercury TDB platform

## Receiving Analogue Values from a Data Manager TDB Program

A simple Data Builder PLC program, running on a Data Manager, is shown below.

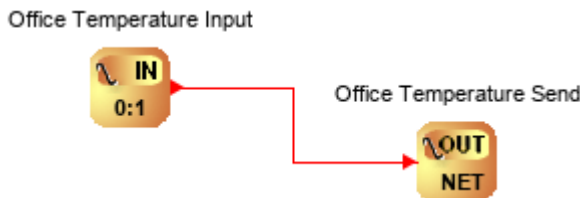

The temperature of a room is being measured from probe 1 on the Data Managers analogue input board and is being connected to an analogue output block. By right-clicking on the 'Analogue Output' block, in the Data Manager TDB program, the options on the right will be shown.

This block has to be configured so that values can be sent to an Intuitive Mercury TDB controller.

- Type: Set to 'Network'.
- Device: Enter the controller name as it appears in the Data Manager's device list, e.g. 'TDB-1'.
- Value: Enter the name of the Network Analogue input, as it appears exactly in the Mercury TDB Program Analogue Input Block name e.g. 'Office Temperature'.



Log the controller onto the Data Manager running the Data Builder program and alias as device 'TDB-1'. Ensure a Network Analogue Input on the controller is configured and that it is entitled 'Office Temperature'. Now the Analogue Input from the Data Manager has been mapped to the controller's Data Builder program.



Please ensure all power is switched off before installing or maintaining this product.

## Network Digital Input

The network digital input block can be used to receive digital values sent from a Data Manager. Once the controller is logged onto a Data Manager, Data Builder programs running within the Data Manager can be used to map digital values to the controller. Please refer to the Desktop Editor User Guide for further details.

### Alarm Signal

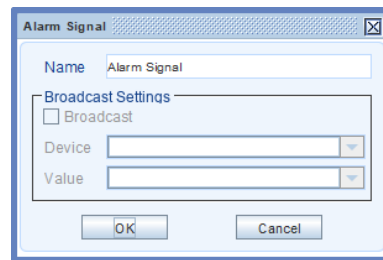
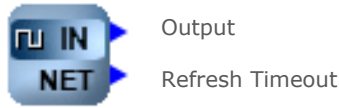

Right click on the icon and select 'properties'. The user can define the Input name.

The 'Device' and 'Value' boxes are not used.

The Input Name has to match the Value box in the Network Digital Output Block on the DM TDB Editor (See below).

**Output:** Outputs the digital network value at any given time from the network source (Data Manager Data Builder program).

**Refresh Timeout:** This output will go true when communications are lost from the network source and the refresh timeout has expired. The refresh timeout value can be changed by right-clicking on the background and selecting [settings](#). **Note:** If communications are lost and the 'Output' is e.g. 'On' then it will remain 'On' until comms are restored. See: [Refresh Timeout](#)

**Broadcast:** Feature not currently supported in the Intuitive Mercury TDB platform

## Receiving Digital Values from a Data Manager TDB Program

A simple Data Builder PLC program, running on a Data Manager, is shown below.

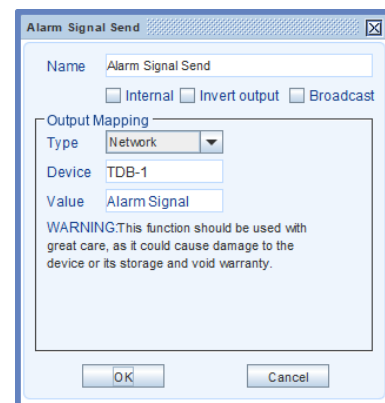
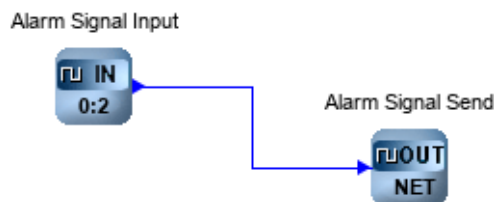

An Alarm Signal is being monitored from Digital Input 2 on the Data Managers input board and is being connected to a digital output block. By right-clicking on the 'Digital Output' block, in the Data Manager TDB program, the options on the right will be shown.

This block has to be configured so that values can be sent to an Intuitive Mercury TDB controller.

**Type:** Set to 'Network'.

**Device:** Enter the controller name as it appears in the Data Manager's device list, e.g. 'TDB-1'.

**Value:** Enter the name of the Network Digital input, as it appears exactly in the Mercury TDB Program Digital Input Block name e.g. 'Alarm Signal'.

Log the controller onto the Data Manager running the Data Builder program and alias as device 'TDB-1'. Ensure a Network Digital Input on the controller is configured and that it is entitled 'Alarm Signal'. Now the Digital Input from the Data Manager has been mapped to the controller's Data Builder program.



Please ensure all power is switched off before installing or maintaining this product.

## Refresh Timeout

Right click in work space and select 'Settings' from the list of options.

The box opposite will appear in work space.

Change the Refresh timeout to the desired time.

If communications between the Intuitive Mercury TDB controller and Data Manager are lost then the Refresh Timeout output on the Network Analogue Input and Network Digital Input will come on after this time expires. This will remain on until comms are restored

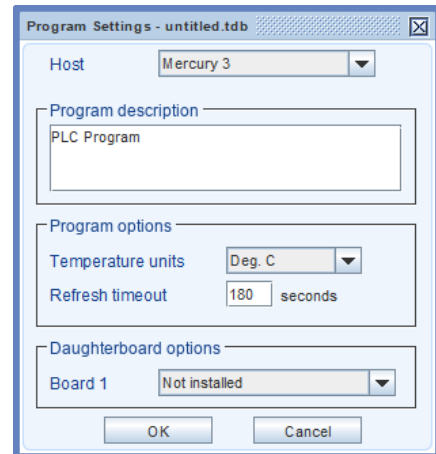

The screenshot shows a dialog box titled "Program Settings - untitled.tdb". It contains the following fields and options:

- Host:** A dropdown menu set to "Mercury 3".
- Program description:** A text area containing "PLC Program".
- Program options:**
  - Temperature units:** A dropdown menu set to "Deg. C".
  - Refresh timeout:** A text input field containing "180" followed by the label "seconds".
- Daughterboard options:**
  - Board 1:** A dropdown menu set to "Not installed".

At the bottom of the dialog are "OK" and "Cancel" buttons.



Please ensure all power is switched off before installing or maintaining this product.

## Specification

Intuitive Mercury TDB Controller PR07XX TDB	
<b>Power requirements</b>	
<b>Supply Voltage Range</b>	100 - 240 Vac $\pm$ 10%
<b>Supply Frequency</b>	50 - 60 Hz
<b>Maximum supply current</b>	2 Amps
<b>Typical supply current</b>	<1 Amp
<b>General</b>	
<b>Operating temperature range</b>	-10°C to +60°C
<b>Storage temperature range</b>	-20°C to +65°C
<b>Environmental</b>	Indoor use at altitudes up to 2000m, pollution degree 1, installation category II. Voltage fluctuations not to exceed $\pm$ 10% of nominal voltage.
<b>Size</b>	157mm (W) x 67mm (H) x 120 (D)
<b>Approx. Weight</b>	500 grams
<b>Safety</b>	EN61010
<b>EMC</b>	EN61326; 1997 +Amdt. A1; 1998
<b>Ventilation</b>	There is no requirement for forced cooling ventilation
<b>Class 2 Insulation</b>	<b>No</b> protective Earth is required and <b>none</b> should be fitted
<b>Supply Fuse</b>	Built in fuse holder, fuse 2A 240Vac Anti-surge (T) HRC conforming to IEC60127, 32 x 6.3mm
<b>Or MCB</b>	2A, 240 VAC Type C conforming to BS EN 60898. Note: device has integral 2A fuse
<b>Relay Fuse</b>	10A 240Vac Anti-surge (T) HRC conforming to IEC60127, 32 x 6.3mm
<b>Relay Specification</b>	
<b>Mechanical Relays</b>	
<b>Max current</b>	10A Resistive (Cos $\phi$ = 1) 3A Inductive (Cos $\phi$ = 0.4)
<b>Max voltage</b>	250Vac. 30V dc
<b>Relay Fuse</b>	10A 240Vac Anti-surge (T) HRC conforming to IEC60127, 32 x 6.3mm
<b>Solid State Relays (if Fitted)</b>	
<b>Max current</b>	1.0A
<b>Max voltage</b>	250Vac (ac only, will not switch dc)
<b>Inputs</b>	
<b>Probe Input resistance</b>	3.01K Ohms (for PTC or NTC type probes)
<b>Probe Input type</b>	Selectable
<b>Digital Inputs</b>	Volt Free
<b>Universal I/O</b>	
<b>4-20mA Input / Output</b>	
<b>Input</b>	4-20mA current loop, use the 12Vdc output to feed the 4-20mA device
<b>Output</b>	The 4-20mA output will not operate correctly if the target device input impedance is > 75 $\Omega$
<b>0-5 or 0-10V Input / Output</b>	
<b>Input</b>	Connect a 0-5 or 0-10V Signal, a 5V supply is provided to feed the sensor.
<b>Output</b>	The output will not operate correctly if the target device input impedance is < 10K $\Omega$ . A 50mA fuse is recommended for this output.



Please ensure all power is switched off before installing or maintaining this product.

## Daughter Card Specification (If used)

### 4-20mA Input / Output

Input: 4-20mA current loop, use the 12Vdc output to feed the 4-20mA device.  
 Output: The 4-20mA output will not operate correctly if the target device input impedance is  $> 75\Omega$ .

### 0-5 or 0-10V Input / Output

Input: Connect a 0-5 or 0-10V Signal, a 5V supply is provided to feed the sensor.  
 Output: The output will not operate correctly if the target device input impedance is  $< 10K\Omega$ . A 50mA fuse is recommended for this output.

### Probe Input

Inputs: 3.01K Ohms - 0V Return.

## Installation

### Dimensions

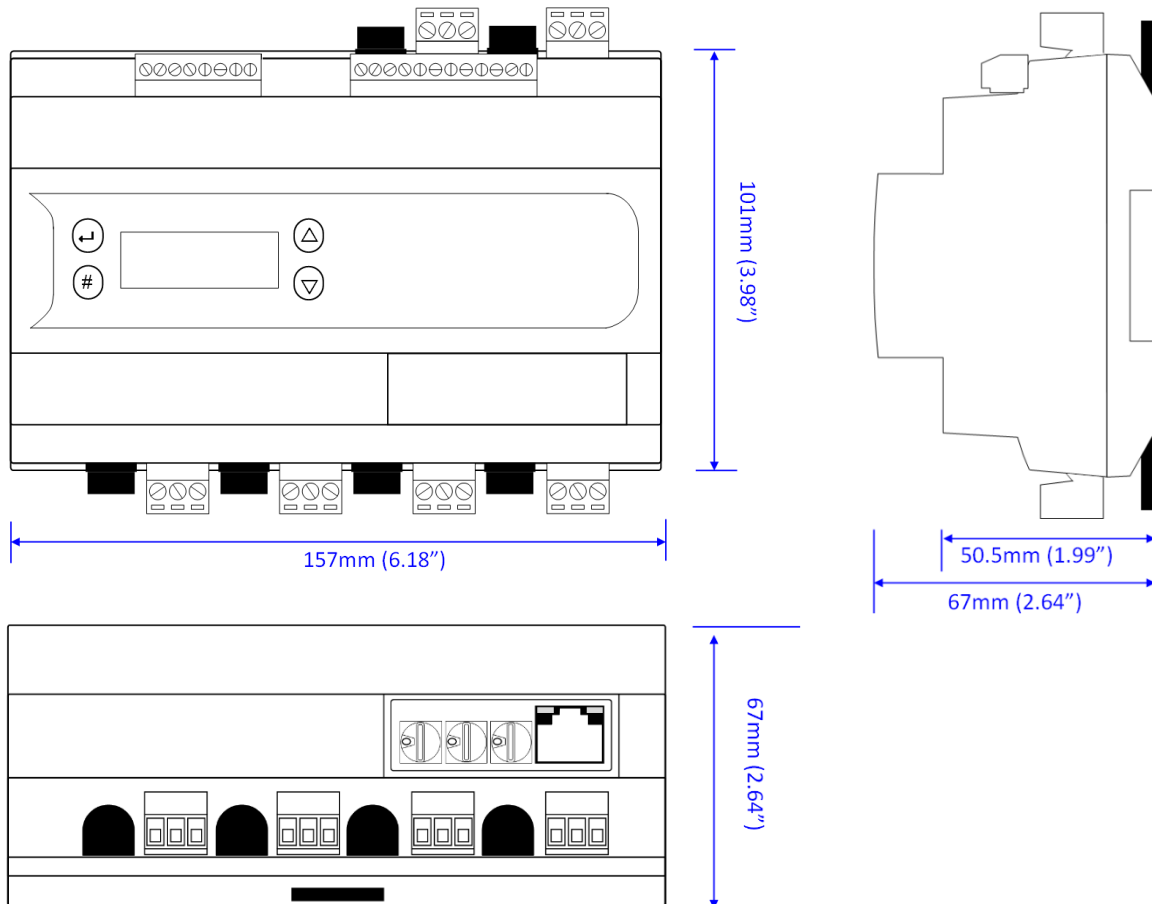

Please ensure all power is switched off before installing or maintaining this product.

## Mounting Instructions

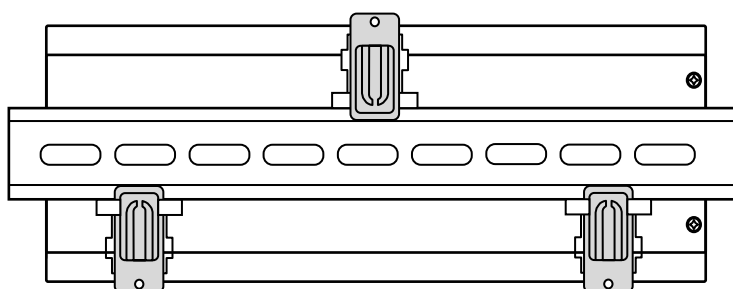

Three clips fix the Intuitive Mercury securely to DIN rail. Pull each clip until it 'clicks' to remove the controller. Each clip has a mounting hole to provide an alternative fixing mechanism to DIN mounting.

## Clearances

The controller must have 10mm clearance above the top and 15mm clearance from the sides. Clearance at the front and rear is dependent on the site wiring.

There is no requirement for forced cooling ventilation

## Cleaning

Do not wet the controller when cleaning. Clean the front by wiping with slightly dampened lint free cloth.

## Disclaimer

The specifications of the product detailed in this document may change without notice. RDM Ltd shall not be liable for errors or omissions, for incidental or consequential damages, directly or indirectly, in connection with the furnishing, performance or misuse of this product or document.

## Terms of Use

Software running on this equipment is licensed for use. In using this equipment you are agreeing to Resource Data Management Ltd's standard Terms and Conditions for Software Licensing. To obtain a copy of the Terms and Conditions please visit our website [www.resourcedm.com](http://www.resourcedm.com) and select Technical Documentation.



Please ensure all power is switched off before installing or maintaining this product.

# Appendix 1: Comfort Index

Apparent Temperature for Values of Room Temperature and Relative Humidity (Shown in Degree F)

	0%	5%	10%	15%	20%	25%	30%	35%	40%	45%	50%	55%	60%	65%	70%	75%	80%
<b>115</b>	117.1	118.0	119.0	119.9	120.8	121.6	122.5	123.5	124.4								
<b>110</b>	111.1	112.0	113.0	113.9	114.8	115.6	116.5	117.5	118.4	119.3	120.1						
<b>105</b>	105.1	106.0	107.0	107.9	108.8	109.6	110.5	111.5	112.4	113.3	114.1	115.0	116.0				
<b>100</b>	99.2	100.1	101.0	101.9	102.8	103.7	104.6	105.5	106.4	107.3	108.2	109.1	110.0	110.9	111.8		
<b>95</b>	93.1	94.0	95.0	95.9	96.8	97.6	98.5	99.5	100.4	101.3	102.1	103.0	104.0	104.9	105.8	106.6	107.5
<b>90</b>	87.1	88.0	89.0	89.8	90.7	91.6	92.5	93.4	94.3	95.2	96.1	97.0	97.9	98.8	99.7	100.6	101.5
<b>85</b>	81.1	82.0	83.0	83.9	84.8	85.6	86.5	87.5	88.4	89.3	90.1	91.0	92.0	92.9	93.8	94.6	95.5
<b>80</b>	75.1	76.0	77.0	77.9	78.8	79.6	80.5	81.5	82.4	83.3	84.1	85.0	86.0	86.9	87.8	88.6	89.5
<b>75</b>	69.2	70.1	71.0	71.9	72.8	73.7	74.6	75.5	76.4	77.3	78.2	79.1	80.0	80.9	81.8	82.7	83.5
<b>70</b>	63.1	64.0	65.0	65.8	66.7	67.6	68.5	69.5	70.3	71.2	72.1	73.0	74.0	74.8	75.7	76.6	77.5

Apparent Temperature for Values of Room Temperature and Relative Humidity (Shown in Degree C)

	0%	5%	10%	15%	20%	25%	30%	35%	40%	45%	50%	55%	60%	65%	70%	75%	80%
<b>46.1</b>	47.3	47.8	48.3	48.8	49.3	49.8	50.3	50.8	51.3								
<b>43.3</b>	43.9	44.4	44.9	45.1	45.9	46.4	46.9	47.4	47.9	48.4	48.9						
<b>40.6</b>	40.7	41.2	41.7	42.2	42.7	43.2	43.7	44.2	44.7	45.2	45.7	46.2	46.7				
<b>37.8</b>	37.3	37.8	38.3	38.8	39.3	39.8	40.3	40.8	41.3	41.8	42.3	42.8	63.3	43.8	44.3		
<b>35.0</b>	34.0	34.5	35.0	35.5	36.0	36.5	37.0	37.5	38.0	38.5	39.0	39.5	40.0	40.5	41.0	41.5	42.0
<b>32.2</b>	30.6	31.1	31.6	32.1	32.6	33.1	33.6	34.1	34.6	35.1	35.6	36.1	36.6	37.1	37.6	38.1	38.6
<b>29.4</b>	27.2	27.7	28.2	28.7	29.2	29.7	30.2	30.7	31.2	31.7	32.2	32.7	33.2	33.7	34.2	34.7	35.2
<b>26.7</b>	24.0	24.5	25.0	25.5	26.0	26.5	27.0	27.5	28.0	28.5	29.0	29.5	30.0	30.5	31.0	31.5	32.0
<b>23.9</b>	20.6	21.1	21.6	22.1	22.6	23.1	23.6	24.1	24.6	25.1	25.6	26.1	26.6	27.1	27.6	28.1	28.6
<b>21.1</b>	17.3	17.8	18.3	18.8	19.3	19.8	20.3	20.8	21.3	21.8	22.3	22.8	23.3	23.8	24.3	24.8	25.3



Please ensure all power is switched off before installing or maintaining this product.

## Appendix 2: Webpage Appearance

It is possible to view the controller across an IP connection using one of the methods outlined in the [Network Configuration](#) section

The following screens are samples of how values and settings appear when viewed through a PC/Laptop connection.



Click on the **Inputs & Outputs** button to view the list of current I/O or the **Parameters** button to view (only) the list of parameters within the TDB device.

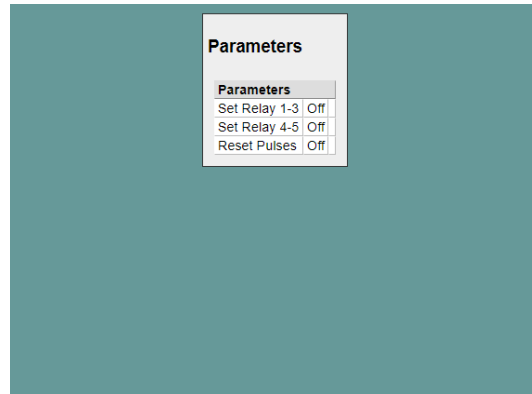
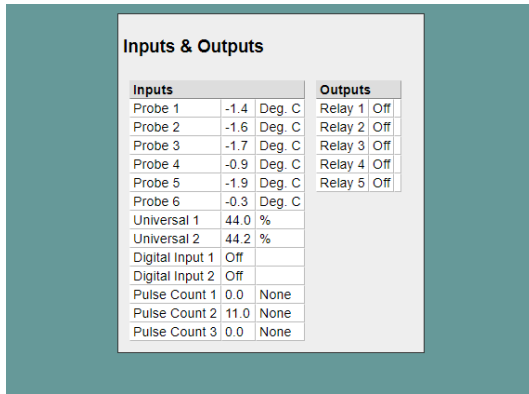

Alternatively, click on the **Configure** button to access the setup menu.

**Note:** login credentials required to access Configure menu are as follows;

Username: 'service'  
 Password: '1234'

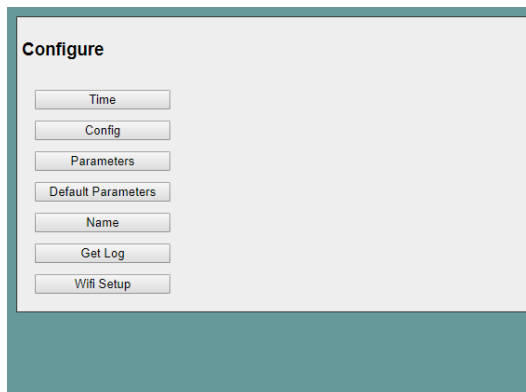

Please ensure all power is switched off before installing or maintaining this product.

Click on the **Time** button to set the controllers 'real time clock'. **Note:** when connected to a Data Manager, the time will automatically sync itself.

When the controller is used as a standalone device and not connected to a network (e.g. DM), the RTC will automatically follow the British Summer Time Zone as long as the below string is present;

**GMT0BST-1,M3.5.0/01:00:00,M10.5.0/02:00:00**

Selecting the **Config** button allows the logging period to be set to one of; 15 minutes, 30 minutes or 60 minutes.

15 minutes will log on the hour and every 15 minutes thereafter

30 minutes will log on the hour and on the half hour

60 minutes will log on the hour every hour

The amount of log data stored within the controller is dependent on the number of I/O used in your TDB program and the logging period selected. For example the controller can record up to 7 days of log data, with a 15 minute sample rate, when up to 63 inputs/outputs are used within the TDB.

Selecting the **Parameters** button allows the parameters within the TDB device to be changed.

Parameter Name	Low	High	Default	Value	Units
Set Relay 1-3	Off	On		Off ▼	
Set Relay 4-5	Off	On		Off ▼	
Reset Pulses	Off	On		Off ▼	

Set Parameters

Selecting **Default Parameters** will return the parameters back to their original settings as set in the TDB program.

Selecting **Name** allows the name of the TDB device to be set.

Selecting **Get Log** will download the current log file in csv format from midnight to present time.

To view the csv file from within an Excel spreadsheet; from the Data tab, within the 'Get External Data' section, select 'From Text'. Navigate to the location of the downloaded csv file and select.

To view data for a specific period the URL can be edited from within the web browser as detailed below;

**<http://xxx.xxx.xxx.xxx/log.htm?Start=hhmmddMMyy&End=hhmmddMMyy>**

xxx: Is the IP address of the TDB device  
 hh: Hours  
 mm: Minutes  
 dd: Day  
 MM: Month  
 Yy: Year (19 for year 2019)

Note that there is a start time and an end time. To view data with a start time only until the present time use the below;

**<http://xxx.xxx.xxx.xxx/log.htm?Start=hhmmddMMyy>**

**Note:** There is a limit to how much data can be displayed so if all data requested is not shown you will have to get the log again from when it stopped previously. If logging digital outputs the log will show 0.0 for off and 1.0 for on.



Please ensure all power is switched off before installing or maintaining this product.

## Appendix 3: Uploading a TDB program from the Data Manager

**IMPORTANT:** Upload and Download via a Data Manager is only available from Data Manager Software V3.1.0 and above.

It is possible to upload and download the TDB program to and from the Intuitive Mercury when it is logged on to a Data Manager. The two methods, detailed for logging the controller on within the Network configuration section, are by using the Data Manager's DHCP capabilities or manually assign a static IP address and add it from within the DM's menus.

With no TDB application loaded, the controller automatically logs on using the DHCP server showing the device name as per the rotary switch ID (e.g. 222) it has associated to it. It will show in the device list with the alias; 'Mercury 3 TDB: No Program' and the corresponding control state will show 'No Program'.

### Uploading via the Data Manager

Once the device is listed within the Data Manager's device list it can now have the TDB program sent to it.

To send the program, through the Data Manager, the plc program written for the Intuitive Mercury TDB must be saved as a binary TDB program (.btodb).

Within the Data Manager's web pages, navigate to; Service/ Devices/ Mercury TDB.

This page will show a list of all Intuitive Mercury TDB controllers logged on to the Data Manager;

The screenshot shows a web interface with a dark theme. At the top, there is a label 'Mercury Password:' followed by an empty text input field. Below this is a table with the following structure:

Device	Description	Panel ID	Action
TDB-1	Mercury TDB	---	<input type="button" value="Send"/> <input type="button" value="Get"/>

Ensure the correct device is recognised as the one the program is to be sent.

Within the 'Mercury Password' field, if the TDB program (being sent) has a '**write**' password, enter it here, otherwise, leave the field blank. Then click the 'Send' button.

From the next page select 'choose file', then navigate to the location of the saved TDB program. Then click 'Upload'. The program will be sent to the controller.

**Note:** When uploading a new/ amended program it is always advisable to 'Default' all parameters. This will take out all values previously entered into the program from the Data Manager or Controller web pages.

### Downloading via the Data Manager

Similarly to the uploading of the program, from the same menu, pictured above, select the 'Get' button. Within the 'Mercury Password' field, if the TDB program (being received) has a '**read**' password, enter it here, otherwise, leave the field blank. This will allow the current program to be saved to your local machine.



Please ensure all power is switched off before installing or maintaining this product.

## Revision History

Revision	Date	Changes
3.0	18/09/2019	First Release
3.1	04/02/2020	Cover page image replaced
3.2	27/10/2022	Pulse Input block removed.
3.3	29/12/2023	SSR current rating updated.
3.4	23/01/2025	Relay daughter board part number added.



Please ensure all power is switched off before installing or maintaining this product.

## Group Offices

### RDM Group Head Office

80 Johnstone Avenue  
Hillington Industrial Estate  
Glasgow  
G52 4NZ  
United Kingdom

+44 (0)141 810 2828  
[support@resourcedm.com](mailto:support@resourcedm.com)

### RDM Inc

100 North Sixth Street  
Suite 630B  
Minneapolis, MN  
55403  
United States

+1 612 354 3923  
[usasupport@resourcedm.com](mailto:usasupport@resourcedm.com)

### RDM Asia

Sky Park at One City  
Jalan USJ 25/1  
47650 Subang Jaya  
Selangor  
Malaysia

+60 3 5115 0061  
[info@rdmasia.com.my](mailto:info@rdmasia.com.my)



Visit [www.resourcedm.com/support](http://www.resourcedm.com/support) for more information on RDM solutions, additional product documentation and software downloads.

While every effort is made to ensure the information given within this document is accurate, Resource Data Management Ltd shall not be liable for errors or omissions, for incidental or consequential damages, directly or indirectly, in connection with the furnishing, performance or misuse of this product or document. All specifications are subject to change without notice. See [www.resourcedm.com](http://www.resourcedm.com) for terms and conditions of sales.

Copyright © Resource Data Management