

Resource
Data Management

Mercury 3 Two Section Controller

Commissioning/User Guide
Revision 3.2b



PR0740-TWO

Contents

The Mercury 3 Range.....	4
From Resource Data Management	4
Description:.....	4
Variants.....	4
Compatible Displays.....	4
Configuration	4
Compatible Network Interfaces.....	4
Front Display Features.....	5
Mercury Mk3.....	5
Connections	5
Mercury Mk3 I/O Connections.....	5
Input / Output Allocation Tables	6
Input / Output allocation table	6
Switched Resistor Values.....	6
Ordering Information	7
Setting up the controller	7
Setup through front buttons	7
Setup Function Menu (Common to all types).....	7
Recommended set-up method	7
rtc. Real time clock (This will automatically synchronise on network systems).....	8
type. Set/view controller type	8
PArA. Set/view parameters (This can be achieved at the network front end).....	8
Unit. Set/view temperature unit and Probe type.....	8
Display	9
Parameter Tables.....	9
Parameter Descriptions	11
Relay State and functional operation	13
Network Configuration – RS232 comms.....	14
RS485 Legacy module	14
Wireless Mesh Module.....	15
IP Futura module	15
Mercury Switch	16
Network Configuration – IP comms	16
Data Manager Device list	17
Viewing	17
Input / Output Table.....	17
Display Messages.....	18
Network Alarms.....	18
Modifying controller states	19
Defrost “dEF”	19



Please ensure all power is switched off before installing or maintaining this product.

Fans Only "FAnS"19
Case Off "CASE"19
Lights Only "LitS"19
Probe Offset19
Operation19
Display Operation.....19
Remote Commands20
Specification21
Switched Resistor Example Wiring22
Installation & Dimensions22
 Panel Cut-out and Clearances22
 Fixing22
 Dimensions22
 Cleaning.....22
Disclaimer.....23
Appendix 1 Defrost Cycles.....23
Revision History24



Please ensure all power is switched off before installing or maintaining this product.

The Mercury 3 Range

From Resource Data Management

Description:

This controller is for use with a 2-section refrigeration display case with a single evaporator. It has 6 different controller types to accommodate various display cases such as HT/LT piped, integrals and cold-rooms. The controller uses the Mercury 3 hardware which operates the LLV using an electro-mechanical relay and is therefore not suitable for use with EEV operations.

The controller supports PT1000, NTC2K, 470R, 700R, 3K, 5K, 6K, NTC2K25 or NTC10K temperature probes (note: probe types cannot be mixed)

Variants

Inputs/ Outputs	Display	Comms
6 Probe, 2 Digital Inputs / 5 Relay Outputs	Integral/ Remote Display	Serial/ Ethernet

Compatible Displays

The following displays are compatible with the Mercury Remote Display Controllers:-

Description	Part Number
Mercury Remote Display with 5m cable	PR0325
Mercury Keyswitch Remote Display with 5m cable	PR0326
Mercury DIN Remote Display with 5m cable	PR0327
Mercury DIN Keyswitch Remote Display with 5m cable	PR0328
Mercury mk2 Remote Display with 5m cable	PR0725

Configuration

The controller gives you up to six configuration options:-

Display value	
1	Integral controller HT
2	Integral controller LT
3	Remote piped case controller LT
4	Remote piped case controller HT
5	Coldroom controller LT
6	Coldroom controller HT

The controllers are delivered pre-configured as an Integral controller HT (Type 1)

Compatible Network Interfaces

Mercury controllers which do not have an IP interface built in are capable of connecting to either a TCP/IP local area network, an RS485 Genus compatible network, an RDM wireless mesh network or they can be used in standalone mode with no network output. To connect to a network you must add the correct communications module. Connecting to any of these communication modules will automatically be detected on power up and will affect the 'Net' menu set up screens available to you. **Note** controllers with built in IP will be able to communicate to any IP switch, including the rear ports of the RDM Mercury Hub.

Description	Part Number
IP Futura (Single Mercury to IP Interface)	PR0016
RS485 Interface (Single Mercury to RS485 Interface)	PR0026
Mercury IP Switch (IP support for 10 controllers)	PR0018
Mercury IP Switch with Pressure/Humidity Inputs	PR0018-PHI



Please ensure all power is switched off before installing or maintaining this product.

Front Display Features

LED's: -

Valve (Relay 1) 

Fans (Relay 2) 

Lights (Relay 3) 

Defrost (Relay 5) 

On-Line Status 

Off No network attached
 Flashing Attempting to Log on to network
 Steady On-line

Service (See Parameter 18 for setup) 

Alarm 

HACCP 

Connections

Mercury Mk3 I/O Connections

Input and Output connections are made to the back of the controller, the RS232/ Ethernet communication port is on the side. The diagram below shows the connection detail. Inputs and outputs are assigned according to the chosen configuration. See [Input/Output](#) tables for further details on connections.



Mercury Mk3



Keys



Note: Function keys illuminate when pressed, illumination is turned off 20 seconds after the key is used.

Defrost: Press and hold the defrost button to force a manual defrost

Main Display



4 character LED display, used to display temperature and status messages.

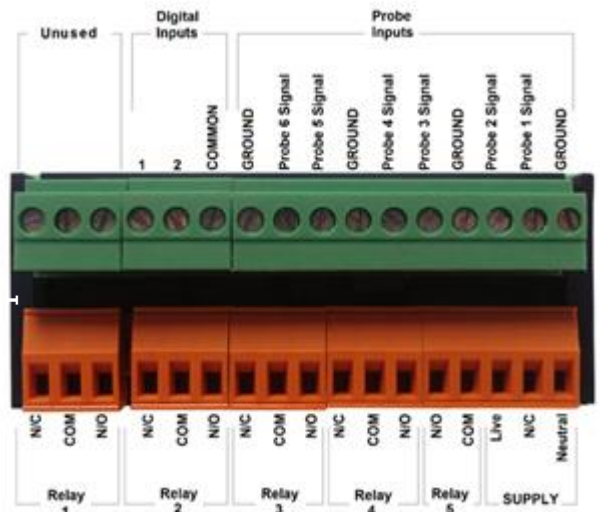

Please ensure all power is switched off before installing or maintaining this product.

Input / Output Allocation Tables

The following tables indicate; on a controller type basis, the functions of the inputs and outputs. Also shown are the digital inputs that are derived by switching in a fixed value resistor across the input.

Input / Output allocation table

TYPE	Integral Case Types 1&2	Remote Case Types 3&4	Coldroom Controller Types 5&6	Alarm Action	Plant Input (Switched Resistors)
Input 1	Air on Section 1	Air on Section 1	Air on Section 1	Yes	
Input 2	Air off Section 1	Air off Section 1	Air off Section 1	Yes	Man Trap (Types 5&6)
Input 3	Defrost Section 1	Defrost Section 1	Defrost Section 1	No	Plant fault 3 / Ext Defrost
Input 4	Air on Section 2	Air on Section 2	Air on Section 2	Yes	
Input 5	Air Off Section 2	Air Off Section 2	Air Off Section 2	Yes	Plant fault 4 (Types 1&2) Door Switch (Types 5&6)
Input 6	Defrost Section 2	Defrost Section 2	Defrost Section 2	No	
Digital 1	Selectable; Plant 1, Switch, Defrost, Plant 2	Selectable; Plant 1, Switch, Defrost	Selectable; Plant 1, Switch, Defrost, Door, Man Trap	Conditional	
Digital 2	Selectable; Plant 1, Switch, Defrost, Plant 2	Selectable; Plant 1, Switch, Defrost	Selectable; Plant 1, Switch, Defrost, Door, Man Trap	Conditional	
Relay 1	Compressor (N/C)	Liquid Line Valve (N/C)	Liquid Line Valve (N/C)	N/A	
Relay 2	Fans (N/C)	Fans (N/C)	Fans (N/C)	N/A	
Relay 3	Lights/Alarm	Lights/Alarm	Lights/Alarm	N/A	
Relay 4	Defrost Section 1 (N/O)	Defrost Section 1 (N/O)	Defrost Section 1 (N/O)	N/A	
Relay 5	Defrost Section 2 (N/O)	Defrost Section 2 (N/O)	Defrost Section 2 (N/O)	N/A	

Switched Resistor Values

For PT1000 probes use 820 Ohm switched resistors. For NTC2K, NTC2K25 and 3K probes use 590 Ohm switched resistors. For 5K and 6K use 1K Ohm switched resistors. For NTC10K probes use 2k7 Ohm switched resistors. The resistors used must have a tolerance of 1% or better and the resistor must have a power rating of 0.25W. For improved accuracy whilst using switched resistors RDM recommend resistors with 0.1% accuracy are used. Note the switched resistor features will **not** function when using 470R or 700R probes. When a resistor is switched across the appropriate input it signals to the Mercury to enable the switched resistor function described for that input whilst still recording the probe temperature on the input.

Temperature range for all probe types is -49°C to +60°C for probe inputs which do not have a secondary function (switched resistors). Inputs which have a secondary function are restricted to -42°C to +60°C. If the full temperature range is required on all inputs and no switch resistor features are needed then please see Switch Resistor parameter P-19

Note: switched resistors will operate in LT (Low Temperature) and HT (High Temperature) applications using PT1000, NTC2K or NTC2K25 probe types only. For all other probe types the switched resistor inputs will work in HT applications only.



Please ensure all power is switched off before installing or maintaining this product.

Ordering Information

When ordering a Mercury Mk 3 controller the following ordering scheme can be used to purchase the desired hardware configuration.

PR0740- Y Z TWO

Y	Description
D	Local/ Integral Display
R	Remote Display

Z	Description
IP	Ethernet Comms
232	RS232 Comms

Example

To order a Mercury MK3 with a Remote display and IP comms;

PR0740 – R IP TWO

Setting up the controller

Access to the controller can be achieved several ways

- Through the front mounted buttons
- Direct access by PC or palm top into the rear comms port. This requires a software package available on the RDM website
- Through legacy front end panels on 485 networks
- Through the RDM Data Manager
- Across an IP network. (Current controller IP address required)

Setup through front buttons



To enter setup mode, hold the Enter and Down buttons together for approximately 3 seconds until the message "Ent" appears on the display. Now press the Enter button again to enter the function menu. IO will be displayed. Scroll up or down to go through the list.

Setup Function Menu (Common to all types)

Display	Option	Explained in Paragraph	Display	Option	Explained in Paragraph
IO	View Inputs / Outputs and States	Input / output table	SoFt	View software version	
PARA	Set/View Parameters	Set view parameters	FANS	Toggle Fans Only mode	Fans
Unit	Probe type and Celsius/Fahrenheit option	Set View Unit	CASE	Toggle Case Off mode	Case Off
diSP	Display whole units or decimal	Display	Ligt	Toggle Lights Only mode	Lights
tyPE	Set/View Controller Type	Set/view controller type	OFSt	Probe Offset	Probe Offset
rtc	Set/view Clock (rtc = Real Time Clock)	Real Time Clock	tEst*	Test Mode	See Note Below
nEt	Set/view network configuration	Network Configuration	ESC	Exit Setup mode	

***Note:** When first powered up the controller will have the 'tEst' option in the menu setup. This allows the user to toggle the relays for testing purposes. Upon entering the menu, the display will show r-01 (relay 1) to r-05 (relay 5), select the desired output and toggle the value from 0 to 1 (confirm by pressing enter) to switch the selected relay.

This option is only available for 30 seconds after power up. After this time, the menu setup will return to its standard options.



Please ensure all power is switched off before installing or maintaining this product.

Recommended set-up method

If you are not connecting to a network and want to set up the controller through the buttons we recommend you use the following order from the function menu.

rtc. Real time clock (This will automatically synchronise on network systems)

- a. Use the up or down buttons to scroll through the display until the display reads "rtc"
- b. Press enter. The display will show "t-1". press enter again
- c. Scroll hours up or down (0 – 23) press enter
- d. Use up button to select "t-2", press enter
- e. Scroll minutes up or down (0 – 59) press enter
- f. Repeat for t-3 (seconds 0 – 59)
- g. Repeat for t -4 (days up to 31)
- h. Repeat for t -5 (months up to 12)
- i. Repeat for t -6 (year up to 99)
- j. Use up button to display "ESC", press enter to display "rtc"

Timeclock is now set

type. Set/view controller type

- a. From the function menu scroll to select type, press enter
- b. Use the up/down buttons to scroll through case/coldroom configuration types. (see [configuration table on](#) page 4)
- c. Press enter.
- d. Scroll to select "ESC"
- e. Press enter

Controller type configuration is now set

PArA. Set/view parameters (This can be achieved at the network front end)

- a. From the function menu scroll to select PArA
- b. Pressing Enter while PArA is displayed will enter the parameter menu. The first parameter option will be displayed as P-01. Pressing the Up or Down button will present the other parameter options P-02, P-03 etc. See the parameter list below to find what parameter number corresponds to which actual parameter. Pressing the Enter button will show the current value of the selected parameter. Press Up or Down to modify the value and press Enter again to save the value. The parameter list number will be displayed again. Two other options are present in the parameter menu – dFLt and ESC. Selecting ESC will exit setup mode. Selecting dFLt will reset all parameters back to the default values for the current type of controller.

Unit. Set/view temperature unit and Probe type

From the function menu scroll to select Unit
Press enter and the value will be displayed: -

Probe Types

0 for PT1000 Celsius	11 for NTC2K25 Fahrenheit
1 for PT1000 Fahrenheit	12 for 5K Celsius
2 for NTC2K Celsius	13 for 5K Fahrenheit
3 for NTC2K Fahrenheit	14 for 6K Celsius
4 for 470R Celsius	15 for 6K Fahrenheit
5 for 470R Fahrenheit	16 for NTC10K Celsius
6 for 700R Celsius	17 for NTC10K Fahrenheit
7 for 700R Fahrenheit	18 for NTC10K(2) Celsius (USA NTC10K)
8 for 3K Celsius	19 for NTC10K(2) Fahrenheit (USA NTC10K)
9 for 3K Fahrenheit	
10 for NTC2K25 Celsius	

Use the up or down keys to select the units and press enter.

This function is now complete



Please ensure all power is switched off before installing or maintaining this product.

Display

From the function menu scroll to and select diSP.

Press enter and one of the following values will be shown: -

0. Controller display will show the whole number and tenths value of a temperature reading. (Default)
1. Controller display will show temperatures as a whole number.

Parameter Tables

Not all parameters apply to all controller types, for example P-06 is the anti short cycle time which applies to integral cases only (types 1 & 2), this parameter will not appear if the controller is set up as a type 3,4,5 or 6 (static case or coldroom). In the following table, the type columns on the right hand side will be greyed out if that parameter does not apply to that controller type.

Number	Parameter	Range °C (°F)	Step	Units	Default LT °C (°F)	Default HT °C (°F)	Type 1&2	Type 3&4	Type 5&6
P-01	Cut-in Temp.	-42 to 30 (-43.6 to 86)	0.1	Deg	-20 (-4)	0.0 (32)		✓	✓
	Cut-in Temp. (Integral)	-42 to 30 (-43.6 to 86)	0.1	Deg	-20 (-4)	3.5(38.3)	✓		
P-02	Diff.	0 to 10 (0 to 18)	0.1	Deg	2 (3.6)	1.5 2.7)		✓	✓
	Diff. (Integral)	0 to 10 (0 to 18)	0.1	Deg	2.5 (4.5)	2.5 (4.5)	✓		
P-51	Control Type	0 (highest), 1 (average)	1		0	0			
P-52	Control Weight (section 1)	0 to 100	1	%	50	50		✓	✓
	Control Weight (section 1) (Integral)	0 to 100	1	%	40	30	✓		
P-53	Display Weight (section 1)	0 to 100	1	%	50	50		✓	✓
	Display Weight (section 1) (Integral)	0 to 100	1	%	40	30	✓		
P-25	Alarm Weight (section 1)	0 to 100	1	%	50	50	✓	✓	✓
P-54	Control Weight (section 2)	0 to 100	1	%	50	50		✓	✓
	Control Weight (section 2) (Integral)	0 to 100	1	%	40	30	✓		
P-55	Display Weight (section 2)	0 to 100	1	%	50	50		✓	✓
	Display Weight (section 2) (Integral)	0 to 100	1	%	40	30	✓		
P-26	Alarm Weight (section 2)	0 to 100	1	%	50	50	✓	✓	✓
P-85	Key-switch mode	0 = case off, 1 = fans only 2 = toggle	1		0	0	✓	✓	✓
P-90	Resistor Case Off	0 (Disabled),1(Enabled)	1		0	0	✓	✓	✓
P-92	Fans temperature mode	0 = Off, 1 = Temperature 2 = Over-temperature 3 = Temp/OT	1		0	0	✓	✓	✓
P-93	Fans Off Temperature	-42 to 30 (-43.6 to 86)	0.1	Deg	-10 (14)	8 (46.4)	✓	✓	✓
P-16	Relay 3 mode	0 = lights, 1 = alarm	1		0	0	✓	✓	✓
P-06	Anti SC Time	00:00 to 15:00	00:05	mm:ss	03:00	03:00	✓		
P-18	Service Interval time	0 to 128	1	KHrs	60	60	✓	✓	✓
P-29	Probe 3 Resistor	0 = Plnt3 NO, 1 = Plnt3 NC, 2 = Defrost	1		0	0	✓	✓	✓
P-100 / P-101	Digital Input 1 / Digital Input 2	Types 1,2,3 & 4 0=Plnt N/O, 1=Plnt N/C, 2=Case Switch, 3=Temp Switch, 4= Defrost	1		DI 1: 0 DI 2: 0	DI 1: 0 DI 2: 0	✓	✓	
		Types 5&6; 0=Plnt N/O, 1=Plnt N/C, 2=Case Switch, 3=Temp Switch, 4= Defrost, 5=Door, 6=Man Trap.	1		DI 1: 3 DI 2: 4	DI 1: 3 DI 2: 4			✓



Please ensure all power is switched off before installing or maintaining this product.

Number	Parameter	Range °C (°F)	Step	Units	Default LT °C (°F)	Default HT °C (°F)	Type 1&2	Type 3&4	Type 5&6
P-102	Cut-In Offset	-30 – 30 (-22 – 86)	0.1	Deg	5	5	✓	✓	✓
P-103	Probe 5 Resistor	0 = Plnt4 NO, 1 = Plnt4 NC, 2 = None	1		0	0	✓		
P-20	OT/UT Alarm Delay	00:00 to 99:00	01:00	mm:ss	20:00	20:00	✓	✓	✓
P-21	UT Alarm	-49 to 60 (-56.2 to 140)	0.1	Deg	-30 (-22)	-2 (28.4)	✓	✓	✓
P-22	OT Alarm	-49 to 60 (-56.2 to 140)	0.1	Deg	-15 (5)	5 (41)	✓	✓	✓
P-27	Section 1 Probe 2 Alarm	0 (Off), 1 (On)			On	On	✓	✓	✓
P-28	Section 2 Probe 2 Alarm	0 (Off), 1 (On)			On	On	✓	✓	✓
P-40	Defrost Mode	0 (Local), 1 (Remote)			Local	Local	✓	✓	✓
P-41	Defrost Start	00:00 to 23:59	00:01	hh:mm	01:00	01:00	✓	✓	✓
P-42	Defrosts per Day	0 to 8	1		6	6	✓	✓	✓
P-43	No Defrost Time	0 to 25	1	hours	12	12	✓	✓	✓
P-56	Def Terminate section 1	-42 to 30 (-43.6 to 86)	0.1	Deg	14 (57.2)	10 (50)		✓	✓
P-56	Def Terminate section1 (Integral)	-42 to 30 (-43.6 to 86)	0.1	Deg	10 (50)	10 (50)	✓		
P-57	Def Terminate section 2	-42 to 30 (-43.6 to 86)	0.1	Deg	14 (57.2)	10 (50)		✓	✓
P-57	Def Terminate section 2 (Integral)	-42 to 30 (-43.6 to 86)	0.1	Deg	10 (50)	10 (50)	✓		
P-45	Def Min Time	00:00 to 99:00	01:00	mm:ss	05:00	05:00	✓	✓	✓
P-46	Def Max Time	00:00 to 99:00	01:00	mm:ss	24:00	24:00	✓	✓	✓
P-47	Drain Down	00:00 to 24:00	00:15	mm:ss	01:30	01:30	✓	✓	✓
P-48	Recovery Time	00:00 to 99:00	01:00	mm:ss	30:00	30:00	✓	✓	✓
P-89	Pump Down Time	00:00 to 99:00	01:00	mm:ss	00:00	00:00	✓	✓	✓
P-86	Fan Delay mode	0 = Time 1 = Temp	1		0	0	✓	✓	✓
P-49	Fan Delay Time Types (Cabinet)	00:00 to 99:00	01:00	mm:ss	00:00	00:00		✓	
P-49	Fan Delay Time Types (Integral & Coldroom)	00:00 to 99:00	01:00	mm:ss	03:00	03:00	✓		✓
P-88	Fan Delay Temp	-42 to 30 (-43.6 to 86)	0.1	Deg	-20 (-4)	0.0 (32)	✓	✓	✓
P-50	Fans In Defrost	0 (Off), 1 (On)			On	On	✓	✓	
P-50	Fans In Defrost (Coldroom)	0 (Off), 1 (On)			Off	Off			✓
P-91	Defrost Type	0 = Electric, 1 = Gas	1		0	0	✓		
P-94	Defrost Hold	0 (Off), 1 (On)			Off	Off	✓	✓	✓
P-95	Defrost Skip	0 (Off), 1 (On)			Off	Off	✓	✓	✓
P-96	Def Skip Time	00:00 to 99:00	00:01	mm:ss	12:00	12:00	✓	✓	✓
P-80	Door alarm delay	00:00 to 99:00	01:00	mm:ss	20:00	20:00			✓
P-81	Door closes LLV	0 = No, 1 = Yes			No	No			✓
P-82	Door stops fans	0 = No, 1 = Yes			No	No			✓
P-60	Lights Mode	0 (Local), 1 (Remote), 2 (Man Off), 3(Man On)			Local	Local	✓	✓	✓
P-61	Sun Lights On	00:00 to 23:59	00:01	hh:mm	08:00	08:00	✓	✓	✓
P-62	Sun Lights Off	00:00 to 23:59	00:01	hh:mm	20:00	20:00	✓	✓	✓
P-63	Mon Lights On	00:00 to 23:59	00:01	hh:mm	08:00	08:00	✓	✓	✓
P-64	Mon Lights Off	00:00 to 23:59	00:01	hh:mm	20:00	20:00	✓	✓	✓
P-65	Tue Lights On	00:00 to 23:59	00:01	hh:mm	08:00	08:00	✓	✓	✓
P-66	Tue Lights Off	00:00 to 23:59	00:01	hh:mm	20:00	20:00	✓	✓	✓
P-67	Wed Lights On	00:00 to 23:59	00:01	hh:mm	08:00	08:00	✓	✓	✓
P-68	Wed Lights Off	00:00 to 23:59	00:01	hh:mm	20:00	20:00	✓	✓	✓
P-69	Thu Lights On	00:00 to 23:59	00:01	hh:mm	08:00	08:00	✓	✓	✓
P-70	Thu Lights Off	00:00 to 23:59	00:01	hh:mm	20:00	20:00	✓	✓	✓
P-71	Fri Lights On	00:00 to 23:59	00:01	hh:mm	08:00	08:00	✓	✓	✓
P-72	Fri Lights Off	00:00 to 23:59	00:01	hh:mm	20:00	20:00	✓	✓	✓
P-73	Sat Lights On	00:00 to 23:59	00:01	hh:mm	08:00	08:00	✓	✓	✓



Please ensure all power is switched off before installing or maintaining this product.

Number	Parameter	Range °C (°F)	Step	Units	Default LT °C (°F)	Default HT °C (°F)	Type 1&2	Type 3&4	Type 5&6
P-74	Sat Lights Off	00:00 to 23:59	00:01	hh:mm	20:00	20:00	✓	✓	✓
dFLt	Restore defaults								

Parameter Descriptions

Number	Parameter	Description
P-01	Cut-in Temp	Temperature at which the LLV or compressor will switch on.
P-02	Diff	Differential temperature below the cut-in temperature. The LLV or Compressor switches off when below this temperature
P-51	Control Type	Uses Highest Temperature from Section 1 or 2 as Control Temperature or uses Average Temperature of Section 1 and 2 as Control Temperature
P-52	Control Weight Sect 1	Percentage of Section 1 Air-On temperature probe that is used to calculate Section 1 Control Temp. The remaining percentage will be used on Section 1 Air-Off temperature probe. Example, P-52 set to 30% Control temp = 30% Section 1 Air-on + Section 1 70% Air-off
P-53	Display Weight Sect 1	As above but applied to Section 1 Display Temperature
P-25	Alarm Weight Section 1	As above but applied to Section 1 Over Temperature Alarm. The under temperature alarm uses the weighted control temperature as a reference.
P-54	Control Weight Sect 2	Percentage of Section 2 Air-On temperature probe that is used to calculate Section 2 Control Temp. The remaining percentage will be used on Section 2 Air-Off temperature probe. Example, P-54 set to 60% Control temp = 60% Section 1 Air-on + Section 1 40% Air-off
P-55	Display Weight Sect 2	As above only applied to Section 2 display temperature
P-26	Alarm Weight Section 2	As above but applied to Section 2 Over Temperature Alarm. The under temperature alarm uses the weighted control temperature as a reference.
P-85	Key-switch Mode	Allows the keys switch to be: - Single turn for case off (Case off mode) Single turn for Fans only (Fans Mode) Single turn for case off, double turn for fans only (Toggle mode)
P-90	Resistor Case Off	Turns on/off the switched resistor case off function
P-92	Fans temperature mode	Allows the user to set the fans to turn off when: - A pre-determined temperature is reached (P93) When an over-temperature alarm is present When either P93 is reached or an OT alarm is present
P-93	Fans Off Temperature	Temperature for the above (P92) operation. Note the defrost termination probe is the source of the temperature reading used in this feature. If the defrost termination probe isn't fitted then a similar process to P-56 / P57 is used.
P-16	Relay 3 mode	This changes the function of relay 3 from Lights (default) to an alarm relay. The alarm relay is energised for no alarm. Use the NC and Common for "Loop make" on alarm or use the NO and Common for "Loop break" on alarm.
P-06	Anti SC Time	Allows the user to set the compressor for a given number of starts per hour.
P-18	Service Interval Time (Run Hours)	Time (in 1000 x hours) before the service icon (Spanner icon) comes on. The Run Hours timer increments based on the number of hours the controller has been powered up and running. Reset the spanner icon to off by changing this parameter to 0 and then back to the desired service interval. This process also resets the Run Hours value to 0. To view the current Run Time value refer to the I/O list.
P-29	Probe 3 Resistor	Selects whether the switched resistor invokes a Plant 3 fault (with either N/O or N/C closed contact) or an external defrost.
P-100/ 101	Digital Input 1 / Digital Input 2	Sets the status input type for the two Digital Inputs; <ul style="list-style-type: none"> ➤ Plant 1 – When the DI is activated, it would alarm Plant Fault 1. ➤ Switch – Would carry out the operation set on the 'Key Switch mode' (p-85) ➤ Defrost – The DI activation would signal the unit to go into a defrost (must be set to remote df). ➤ Door – The DI activation would signal if the door is open or closed. ➤ Man Trap – If the DI signal is received, it would activate a Man Trap alarm.
P-102	Cut-In Offset	The value added to the Cut-In Setpoint, OT and UT alarm thresholds when a temperature offset is applied. This can be done from a digital input set to 'Temp Switch' or via a Data Manager TDB command
P-103	Probe 5 Resistor	Selects whether the switched resistor invokes a Plant 4 fault (with either N/O or N/C



Please ensure all power is switched off before installing or maintaining this product.

Number	Parameter	Description
		closed contact).
P-20	Alarm Delay	Delay for the over and under-temperature alarms
P-21	UT Alarm	Under temperature alarm set point. This alarm uses the control temperature.
P-22	OT Alarm	Over temperature alarm set point. This alarm uses the air-off temperature.
P-27	Section 1 Probe 2 Alarm	Allows the section 1 air off probe fail alarm to be disabled if the air off probe is not fitted. Control and alarm functions will transfer to the air on probe.
P-28	Section 2 Probe 2 Alarm	Allows the section 2 air off probe fail alarm to be disabled if the air off probe is not fitted. Control and alarm functions will transfer to the air on probe.
P-40	Defrost Mode	Allows the user to set the defrost mode: - Local (Uses the internal parameters P-41 and P-42) Remote (Requires a defrost schedule in the front end)
P-41	Defrost Start	When defrost mode is set to "Local", this is the start time for the 1 st defrost
P-42	Defrosts per Day	When defrost mode is set to "Local", this is the number of defrosts per day equally spaced from the start time.
P-43	No Defrost Time	If the controller misses a defrost command for any reason, a defrost will initiate after this time has elapsed from the last defrost. Normally set to 2 hours over the normal defrost period.
P-56	Def Term Section 1	The defrost for Section 1 will terminate (Defrost Heater Section 1 relay off) when the temperature of Section 1 defrost termination probe reaches this value. If Section 1 Defrost Termination probe is not fitted, defrost termination will occur when: - The "air off" probe reaches the set point If the Air Off probe is faulty termination will occur on Time.
P-57	Def Term Section 2	The defrost for Section 2 will terminate (Defrost Heater Section 2 relay off) when the temperature of Section 2 defrost termination probe reaches this value. If Section 2 Defrost Termination probe is not fitted, defrost termination will occur when: - The "air off" probe reaches the set point If the Air Off probe is faulty termination will occur on Time.
P-45	Def Min Time	Minimum time that a defrost will use (Defrost can't terminate until this time has elapsed. If termination temperature is reached during this period, the defrost control relay is turned off, but the controller will not continue the defrost cycle until the end of the defrost min period)
P-46	Def Max Time	Time period after defrost minimum that defrosts are allowed to terminate
P-47	Drain Down	A period after defrost max to allow the draining of any surplus water
P-48	Recovery Time	The LLV is switched on at the start of this period to allow the temperature to recover to the normal operating point. This period also inhibits the OT alarm. Note that if the air-off temperature is still above the OT alarm setpoint when this period expires, an immediate OT alarm occurs; there is not a further alarm delay.
P-89	Pump Down Time	Time period before the defrost min period to allow for a pump down
P-86	Fan Delay mode	This parameter allows the fans start after a drain-down period to be delayed, either by time (P-49) or when the temperature point (P-88) is reached. This parameter uses the same probe strategy as the defrost terminate.
P-49	Fan Delay	Time after a drain-down period before the fans start if P-86 is set to time
P-88	Fan Delay Temp	Temperature which the fans start after drain-down time when P-86 is set to temperature.
P-50	Fans In Defrost	Allows the user to set the fans on or off in defrost. Note if the fans are set to on in defrost, they will go off for the drain-down period and then follow the P-86 rules.
P-94	Defrost Hold	Turns the defrost hold feature on and off. When switched on, the controller can be held in defrost until a remote command from the front end starts the recovery process.
P-95	Defrost Skip	Allows user to enable/disable defrost skip. This feature allows the controller to skip defrosts. If the current defrost terminates on temperature then the controller will skip the next scheduled defrost providing the previous defrost terminated before the defrost skip time (P-96).
P-96	Def Skip Time	Time factor used in defrost skip. The previous defrost has to terminate before this value expires to allow the controller to skip a defrost.
P-80	Door alarm delay	Delay after the door open input is activated before the alarm occurs.
P-81	Door Closes Valve	This parameter is used to close the LLV or EEV if the door opens. If the door remains open then the valve will resume normal operation on the expiry of the door alarm delay (P-80).
P-82	Door Stops Fan	This parameter is used to stop the fans if the door opens. If the door remains open then the fans will resume normal operation on the expiry of the door alarm delay (P-80).
P-60	Lights Mode	Allows the user to set the lights mode: - Always off Always on Use a local schedule P-61 to P-74)



Please ensure all power is switched off before installing or maintaining this product.

Number	Parameter	Description
		Use a remote schedule (Set up in the system front end)
P-61	Sun Lights On	When P-60 is set to Local, Sunday on time
P-62	Sun Lights Off	When P-60 is set to Local, Sunday off time
P-63	Mon Lights On	When P-60 is set to Local, Monday on time
P-64	Mon Lights Off	When P-60 is set to Local, Monday off time
P-65	Tue Lights On	When P-60 is set to Local, Tuesday on time
P-66	Tue Lights Off	When P-60 is set to Local, Tuesday off time
P-67	Wed Lights On	When P-60 is set to Local, Wednesday on time
P-68	Wed Lights Off	When P-60 is set to Local, Wednesday off time
P-69	Thu Lights On	When P-60 is set to Local, Thursday on time
P-70	Thu Lights Off	When P-60 is set to Local, Thursday off time
P-71	Fri Lights On	When P-60 is set to Local, Friday on time
dflt	Restore default values	Restores all the parameters to their default values

Relay State and functional operation

Relay 1-3 State	Function State	Wired contact	Relay 4-5 State	Function State	Wired contact
Relay 1 off	Valve / Compressor on	N/C	Relay 3 off	Alarm Relay = Alarm	N/C
Relay 1 on	Valve / Compressor off	N/C	Relay 3 on	Alarm Relay = OK	N/C
Relay 2 off	Fans on	N/C	Relay 4 off	Defrost Heater 1 off	N/O
Relay 2 on	Fans off	N/C	Relay 4 on	Defrost Heater 1 on	N/O
Relay 3 off	Lights on	N/C	Relay 5 off	Defrost Heater 2 off	N/O
Relay 3 on	Lights off	N/C	Relay 5 on	Defrost Heater 2 on	N/O



Please ensure all power is switched off before installing or maintaining this product.

Network Configuration – RS232 comms

The final section to setup is the network address. In all instances, this must be done before the controller is connected to the site network.

When logging a Mercury 3 with an RS232 interface onto a network you must first connect the controller to a communications module, this is either a 485 Legacy, IP Futura, Mercury Switch or Wireless Mesh Interface. For Mercury 3's with the IP interface please refer to the [Network Configuration – IP comms](#) section for details of networking.

RS485 Legacy module

Using RS485, the controllers have an auto-initialise function, which will automatically log the device onto the site network. If the wrong address has been entered onto the network, you will have to reset the controller address by setting the address to 00-0, and then re-enter the correct address (you may have to deregister the wrong address from the home system as well).

Connecting an RS485 legacy Module to the controller will govern which set-up screens are made available in the **'Net'** menu. The module will support the "Genus" protocol only. Using RS485 will show the below;

Display	Option
485t	485 Network Type
485A	485 Address/ Name
gAdd	Show underlying network address assigned to controller
rLog	Re-log the controller back onto the network
ClrA	Clear the address/name from the controller
ESC	Exit network menu. N.B. this option must be selected to save any changes made in this menu

The **485t** option shows a value representing the network type. The possible values are:

Value	Network Type
1	Genus compatible (all versions)
2	RDM Wireless Mesh System (Wireless Mesh)

Ensure option '1' is selected (for RS485).

The **485A** option shows a value representing the name of the controller in a Genus compatible network. For example, if the value shown in 485A is shown as "05-6". The controller would try to log onto a Genus compatible network using the name 'RC05-6'.

The **gAdd** option displays (in hexadecimal format) the underlying network address assigned to the controller when it was logged onto the network. Note: this is automatically assigned by the Data Manager.

The **rLog** option allows the controller to be logged back onto the network with its current name. The 'rLog' message will flash, waiting for confirmation. To confirm, press the Enter button to execute the command, Up or Down buttons to cancel.

The **CLrA** option will clear out the network address and name in the controller. The 'CLrA' message will flash for confirmation. Press the Enter button to execute the command, Up or Down buttons to cancel.

Fast Network Address Reset

To enter this mode, hold the Enter, Up and Down buttons together for approximately 3 seconds until the message CLrA appears on the display. CLrA is the first option in the menu consisting of the following options:

Display	Option
CLrA	Clear the address/name from the controller
ESC	Exit Setup mode

Pressing the Enter button to select the CLrA option will cause the 'CLrA' message to flash for confirmation, if the network type is set to Genus compatible. Press the Enter button to execute the command, Up or Down buttons to cancel. If the network type is not set to Genus compatible then the CLrA message will not flash and the ESC option can be used to exit the menu.



Please ensure all power is switched off before installing or maintaining this product.

Wireless Mesh Module

When a wireless mesh module is connected to the controller the 'Net' menu will show similar options to that of the 'RS485' network. The only difference to the settings would be that the **485t** should be set for '2'. Then the same steps should be taken to that of the RS485 option to log the unit on to the wireless mesh. Note, the wireless mesh network should already be set up on the data manager. Please see the Data Manager documentation for setup instructions. Furthermore, please see documentation on the PR0730 Wireless Mesh Network Module for setup instructions.

IP Futura module

In an IP system there are two options;

- IP-L
- IP-r

IP-L allows you to fix a static IP address into the controller, which you would use when you are connecting the controllers onto a customer's local area network. This would allow the customer to view each controller using a generic Internet browser.

IP-r allows you to give each controller on the system a unique number (using the rotary switches). This number is then allocated a dynamic IP address by the system's DHCP server (such as the RDM Data Manager).

IP-L

To configure the communication module, set all three rotary switches to zero. The module should then be connected to the controller.

- From the function menu you can now select '**nEt**'.
- Press enter and the display will show "IP-L", press enter once more.
- You can now set the IP network settings by using the table below

Display	Option
IP-1	IP Address byte 1
IP-2	IP Address byte 2
IP-3	IP Address byte 3
IP-4	IP Address byte 4
nL	Network Mask Length
gt-1	Gateway Address byte 1
gt-2	Gateway Address byte 2
gt-3	Gateway Address byte 3
gt-4	Gateway Address byte 4
ESC	Exit network menu. N.B. this option must be selected to save any changes made in this menu

IP-r

To configure the communication module for IP-r, set the three rotary switches to give each controller a unique identifier. The module should then be connected to the controller and the network. The controller should then be powered on to connect to the network.

- From the function menu you can now select '**nEt**'
- Press enter and the display will show "IP-r", press enter once more.
- You can now view (only) the address given by the DHCP server



Please ensure all power is switched off before installing or maintaining this product.

Network Mask Length

To ease setup, a single network mask length value is used. If the address has been specified with a network mask value in dotted IP format e.g. 255.255.255.0 then the table below gives the conversion:

Mask	Length	Mask	Length	Mask	Length
255.255.255.252	30	255.255.254.0	23	255.254.0.0	15
255.255.255.248	29	255.255.252.0	22	255.252.0.0	14
255.255.255.240	28	255.255.248.0	21	255.248.0.0	13
255.255.255.224	27	255.255.240.0	20	255.240.0.0	12
255.255.255.192	26	255.255.224.0	19	255.224.0.0	11
255.255.255.128	25	255.255.192.0	18	255.192.0.0	10
255.255.255.0	24	255.255.128.0	17	255.128.0.0	09
		255.255.0.0	16	255.0.0.0	08

Mercury Switch

The method of logging on the Mercury 3 (RS232 comms) will be similar to that of the IP Futura however please refer to the Mercury Switch user guide, which can be obtained from the RDM website, for information regarding connecting a controller to a network.

Network Configuration – IP comms

Mercury 3 controllers with the IP interface as standard does not require any communications module and will already communicate on the IP network protocol.

When networking the Ethernet variant, the 'Net' menu will have the following menus;

Display	Option
IP-L / IP-r	Read/ Write Static IP address / Read Only DHCP IP address
Id	The 3 digit network address
AtyP	IP-r / IP-L selection
ESC	Exit Menu

Similar to the IP Futura / switch setup IP-L allows you to fix a static IP address into the controller and IP-r allows you to give each controller on the system a unique network number (using the Id).

- To firstly select between IP-L and IP-r navigate to 'AtyP'.

IP-r

Once IP-r is selected the controller must be given a unique 3 digit 'network address' that no other device on the network has (note if logging on to a Data Manager, this will be the device ID). Once the ID has been set connect the controller to the IP network for it then to be given an IP address by the DHCP server. To view the IP address given, within the Net menu, navigate to 'IP-r'.

IP-L

If IP-L has been selected from the 'AtyP' menu the IP address must be given to the controller by navigating to 'IP-L' within 'Net'. The following menu's will be available;

Display	Option
IP-1	IP Address byte 1
IP-2	IP Address byte 2
IP-3	IP Address byte 3
IP-4	IP Address byte 4
nL	Network Mask Length (see the network mask length table above)
qt-1	Gateway Address byte 1
qt-2	Gateway Address byte 2
qt-3	Gateway Address byte 3
qt-4	Gateway Address byte 4
ESC	Exit network menu. N.B. this option must be selected to save any changes made in this menu

Once the IP address has been entered, the controller can be connected to the IP network.



Please ensure all power is switched off before installing or maintaining this product.

Data Manager Device list

Temperatures as they are shown on the Data Manager's device list,

025	2 Section Case (HT)	3.3 2.3 4.2	Normal Normal
-----	---------------------	-------------------	------------------

Control temperature
Section 1 control temperature
Section 2 control temperature

Where:-

Section 1 Control Temperature is the weighted average of Section 1 Air On and Air Off probes (P-52)
Section 2 Control Temperature is the weighted average of Section 2 Air On and Air Off probes (P-54)
Control Temperature is the average of Section 1 Control Temperature and Section 2 Control Temperature. This is the temperature used to control the opening and closing of the LLV/Compressor to Set-Point (P-01)

Viewing

Apart from setting up the controller, you can also view the status of the inputs and outputs and controller states.

From the function menu, select "I/O", press enter. You can now scroll through the IO table as set out below. Inputs and outputs that do not apply to a particular controller type will be greyed out.

Input / Output Table

Number	IO	Range* °C (°F)	Step	Units	Types 1&2	Types 3&4	Types 5&6
I-10	Plant Fault 1	0 (OK), 1 (Alarm)			✓	✓	✓
I-11	Case Clean	0 (Off), 1 (On)			✓	✓	✓
I-12	Door Sensor	0 (Closed), 1 (Open)					✓
I-13	Person Trapped	0 (Ok), 1 (Alarm)					✓
I-14	Plant Fault 2	0 (Off), 1 (On)			✓		
I-15	Plant Fault 3	0 (Off), 1 (On)					
I-16	Plant Fault 4	0 (Off), 1 (On)					
I-18	External Defrost	0 (Off), 1 (On)					
I-30	Section 1 Control temp	-42 to 60 (-43.6 to 140)	0.1	Deg	✓	✓	✓
I-31	Section 1 Display temp	-42 to 60 (-43.6 to 140)	0.1	Deg	✓	✓	✓
I-32	Air on Probe Section 1	-49 to 60 (-56.2 to 140)	0.1	Deg	✓	✓	✓
I-33	Air off Probe Section 1	-49 to 60 (-56.2 to 140)	0.1	Deg	✓	✓	✓
I-34	Defrost term temp Section 1	-42 to 60 (-43.6 to 140)	0.1	Deg	✓	✓	✓
I-35	Section 2 Control temp	-42 to 60 (-43.6 to 140)	0.1	Deg	✓	✓	✓
I-36	Section 2 Display temp	-42 to 60 (-43.6 to 140)	0.1	Deg	✓	✓	✓
I-37	Air on Probe Section 2	-49 to 60 (-56.2 to 140)	0.1	Deg	✓	✓	✓
I-38	Air off Probe Section 2	-49 to 60 (-56.2 to 140)	0.1	Deg	✓	✓	✓
I-39	Defrost term temp Section 2	-42 to 60 (-43.6 to 140)	0.1	Deg	✓	✓	✓
I-40	Section 1 Alarm Temp	-42 to 60 (-43.6 to 140)	0.1	Deg	✓	✓	✓
I-41	Section 2 Alarm Temp	-42 to 60 (-43.6 to 140)	0.1	Deg	✓	✓	✓
O-01	LLV	0 (Off), 1 (On)				✓	✓
O-03	Compressor 1	0 (Off), 1 (On)			✓		
O-04	Compressor 2	0 (Off), 1 (On)			✓		
O-06	Lights	0 (Off), 1 (On)			✓	✓	✓
O-07	Fans	0 (Off), 1 (On)			✓	✓	✓
O-10	Last Defrost Time	00:00 to 23:59	hh:mm		✓	✓	✓
O-13	Last defrost Type	0=None,1=Internal 2=External, 3=Network 4=Display, 5=Timed 6=Forced, 7=Skipped			✓	✓	✓
O-18	Run Time	0 - 128	1	K Hrs	✓	✓	✓
O-20	Door Open Time	00:00 to 23:59		hh:mm			✓
O-21	Door Open Length	00:00 to 03:00		hh:mm			✓



Please ensure all power is switched off before installing or maintaining this product.

Number	IO	Range* °C (°F)	Step	Units	Types 1&2	Types 3&4	Types 5&6
O-31	Section 1 Defrost Heater	0 (Off), 1 (On)			✓	✓	✓
O-32	Section 2 Defrost Heater	0 (Off), 1 (On)			✓	✓	✓
O-33	Section 1 Last Defrost Length	00:00 to 03:00	hh:mm		✓	✓	✓
O-34	Section 2 Last Defrost Length	00:00 to 03:00	hh:mm		✓	✓	✓
O-35	Section 1 Last Defrost Temp	-42 to 60 (-43.6 to 140)	0.1	Deg	✓	✓	✓
O-36	Section 2 Last Defrost Temp	-42 to 60 (-43.6 to 140)	0.1	Deg	✓	✓	✓
O-37	Setpoint Offset	-49 to 60 (-56.2 to 140)	0.1	Deg	✓	✓	✓
O-38	Setpoint Offset	-49 to 60 (-56.2 to 140)	0.1	Deg	✓	✓	✓
S-01	Section 1 Control State	0=Stabilise,1=Normal 2=Df Min, 3=Df Max 4=Drain Down, 5=Fan Delay 6=Recovery, 7=OT Alarm 8=UT Alarm, 9=Fans Only 10=Lights Only,11=Case Off 12=Pump Down,13=Df Hold)			✓	✓	✓
S-02	Section 2 Control State	0=Stabilise,1=Normal 2=Df Min, 3=Df Max 4=Drain Down, 5=Fan Delay 6=Recovery, 7=OT Alarm 8=UT Alarm, 9=Fans Only 10=Lights Only,11=Case Off 12=Pump Down,13=Df Hold)			✓	✓	✓

Display Messages

The following alarms and messages can appear on the Mercury 3 display.

Display Message	System status
Ft	Control Fault
Prb1	Probe 1 Fault
Prb2	Probe 2 Fault
Prb3	Probe 3 Fault
Prb4	Probe 4 Fault
Prb5	Probe 5 Fault
Prb6	Probe 6 Fault
rEC	Control State in Recovery
dEF	Control Sate in Defrost

Display Message	System status
AL	Control State in Alarm
FAnS ONLY	Controller in Fans Only
LitS ONLY	Controller in Lights Only
CASE OFF	Controller in Case Off
Ot	Over Temperature Alarm
Ut	Under Temperature Alarm
door	Door Open Alarm
TrAP	Person Trapped Alarm
PLt1, 2, 3, 4	Plant Fault

Network Alarms

The table below shows the text and associated type number that is sent to the system "front end". The type number is normally used to provide different alarm actions.

Alarm text	Type # (index)
Missed defrost	15
Plant Fault 1, 2, 3, 4	3
Case over temperature	4
Case under temperature	5

Alarm text	Type # (index)
Probe 1,2,4 or 5 Faulty	6
Door Left Open	2
Person Trapped	1



Please ensure all power is switched off before installing or maintaining this product.

Modifying controller states

During normal operation you can change the following states from the function menu.

Defrost "dEF"

Selecting the defrost option starts a defrost cycle. Selecting this option will exit the setup menu automatically. The display will show "dEF"
There is also a remote defrost command which starts a defrost cycle from the network front end or remote system.

Fans Only "FAnS"

Selecting the Fans Only option will put the controller into the Fans Only state if the current state is not Fans Only. If the current state is Fans Only then the controller will change to the Normal state. Selecting this option will exit the setup menu automatically. The display will show "FAnS OnLy"
If a remote display with key switch is being used, this function can be invoked by turning the key switch to the fans only position (90 degrees clockwise) with parameter P85 set to "fans"

Case Off "CASE"

Selecting the Case Off option will put the controller into the Case Off state if the current state is not Case Off. If the current state is Case Off then the controller will change to the Normal state. Selecting this option will exit the setup menu automatically. The display will show "CASE OFF". An alarm is generated, fixed delay of 1 minute, when the controller is placed into the Case Off state.
If a remote display with key switch is being used, this function can be invoked by turning the key switch to the case-off position. (Clockwise 90 degrees) with parameter P85 set to "case".

Lights Only "LitS"

Selecting the Lights Only option will put the controller into the Lights Only state if the current state is not Lights Only. If the current state is Lights Only then the controller will change to the Normal state. Selecting this option will exit the setup menu automatically. The display will show "LitS OnLy"
Note. When lights are being used in "Remote" mode with a timing channel: -
If the controller goes offline, the lights are turned ON after a delay of 5 minutes. The lights will stay on until the controller comes back on-line where they will revert to the state of the timing channel being used.

Probe Offset

This feature allows each probe value to be modified by an "offset". Offset values are from -10°C (-18°F) to +10°C (+18°F) and on a channel basis. Example C1 = Probe 1.

Operation

The LLV (or compressor) relay will operate a thermostatic function based on values of the air probes of the 2 sections. If "Highest" is set, then the relay will operate on the greater of the 2 section values. If "Average" is selected, then it will operate on the combined average of the 2 sections.

Note

The section control temperature is the summation of the section air-on and air-off temperatures, weighted by the value set by the section control weight parameter.

Example: If 30% weighting is selected, the control temperature will be: - (30% of air-on + 70% of air-off).

The display temperature of each section can be weighted similarly.

Once a defrost has been initiated, the normal defrost states will apply to both sections, although both sections must terminate before a drain down occurs.

Display Operation

The display indication will be either the highest value of the two sections or average of the 2 sections, depending on the parameter P-51.



Please ensure all power is switched off before installing or maintaining this product.

Remote Commands

The following commands can be used by a Data Builder program :-

Command	Value to send	Description	Conditions
Defrost Command	1	Initiates a defrost cycle	Defrost mode: remote
Defrost Command	3	Terminates the defrost	Defrost mode: remote Defrost hold: On Defrost min state complete
Setpoint Command	$\pm 18^{\circ}\text{C}$	Is added to or subtracted from the setpoint	
Case Off Command	5 0	Sets the controller to Case Off Restores the controller from Case Off to Normal	
Haccp Command	0 1	HACCP LED OFF HACCP LED On	
Button Command	0 1	Buttons backlights Off Buttons backlights On	
Valve Command	2 1	Shuts the valve off Restores the valve to normal operation	

Use an "Analogue Out" block configured to the controller name and in the value field type in the command you require. Use a "Setting block" as the input to the "Analogue Out" block to send the Value.

See Example on the right, which switches on the Haccp LED on CROOM1

Set Block 1

Name: CROOM1

Type: Analog Internal

Settings:

Value: 1

Min: 0

Max: 2

Units: None

OK Cancel

Java Applet Window



Analog Output 2

Name: HACCP

Units: None Internal

Output Mapping:

Type: Network

Device: CROOM1

Value: Haccp Command

Note: Fixed outputs are only selectable if they do not conflict with DM / DD settings and are not being used by another IO block

OK Cancel

Java Applet Window



Please ensure all power is switched off before installing or maintaining this product.

Specification

Mercury Mk3 Controller PR0740-TWO	
Power Requirements	
Supply Voltage Range	100 - 240 Vac \pm 10%
Supply Frequency	50 - 60 Hz
Maximum supply current	5.2 Amps (when relay 5 is fully loaded)
Typical supply current	<1 Amp
General	
Operating temperature range	-10°C to 60°C (14°F to 140°F)
Storage temperature range	-20°C to 65°C (-4°F to 149°F)
Environmental	Indoor use at altitudes up to 2000m, pollution degree 1, installation category II. Voltage fluctuations not to exceed \pm 10% of nominal voltage.
Size	78mm (W) x 36mm (H) x 110mm (D)
Approx Weight	170 grams
Safety	EN61010
EMC	EN61326; 2013
Ventilation	There is no requirement for forced cooling ventilation
Class 2 Insulation	No protective Earth is required and none should be fitted
Supply Fuse	The host equipment must provide a suitable external over-current protection device such as: - Fuse: 6.3A 240 Vac Antisurge (T) HRC conforming to IEC 60127
Or MCB	6A, 240 VAC Type C conforming to BS EN 60898
Relay Fuse	Not Fitted
Relay Specification	
Relays 1-4 Mechanical Type	
Max current	6A Resistive ($\text{Cos}\phi = 1$) 2A Inductive ($\text{Cos}\phi = 0.4$)
Max voltage	250Vac, 30V dc
Relay Fuse	N/A
Relay 5 Mechanical Type	
Max current	3A (non inductive), $\text{COS}\phi=0.4$ 2A (inductive load) 200,000 operations
Max voltage	250Vac (Internal supply)
For compliance with the LVD, relays 3, 4 and 5 commons must be at the same potential as the supply voltage	
Inputs	
Probe Input resistance	3.01K Ohms (for PTC or NTC type probes)
Probe Input type	Selectable. See: Units
Transducer 0-10V	Connect a 0-10v signal
Transducer 4-20mA	4-20mA current loop, uses the 12 Vdc output to feed the pressure transducer See wiring
Digital Inputs	Volt Free
Comms	
Serial Variant	RS232 with flow control
Ethernet Variant	IP comms



Please ensure all power is switched off before installing or maintaining this product.

Switched Resistor Example Wiring

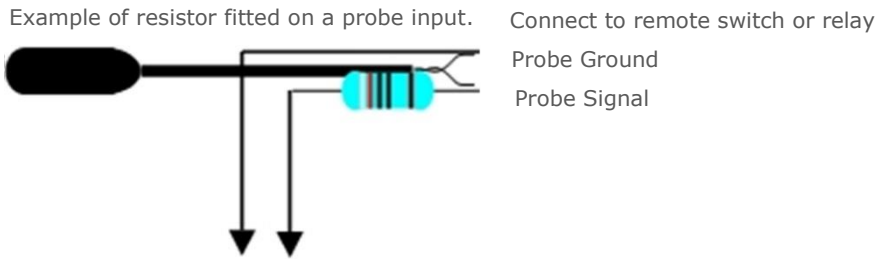

Installation & Dimensions

Panel Cut-out and Clearances

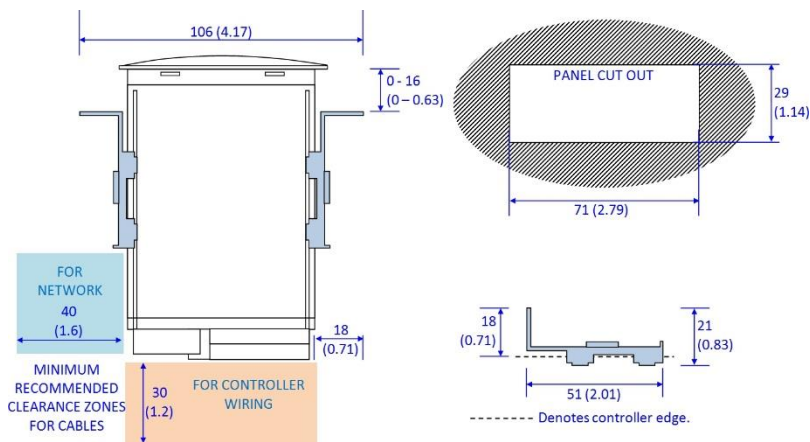

Fixing

The controller is fixed by sliding the 2 plastic retaining clips up to rear of the panel. These clips have a ratchet action and can be removed by holding in the clip sides and sliding back.

There is no requirement for forced cooling ventilation.

Dimensions

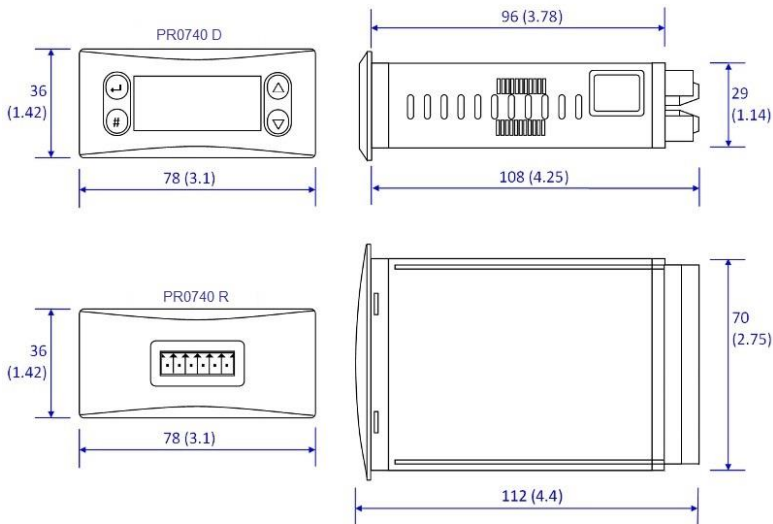

Cleaning

Do not wet the controller when cleaning. Clean the front by wiping with slightly dampened lint free cloth.



Please ensure all power is switched off before installing or maintaining this product.

Disclaimer

The specifications of the product detailed in this document may change without notice. RDM Ltd shall not be liable for errors or omissions, for incidental or consequential damages, directly or indirectly, in connection with the furnishing, performance or misuse of this product or document.

Appendix 1 Defrost Cycles

Fans On in Defrost

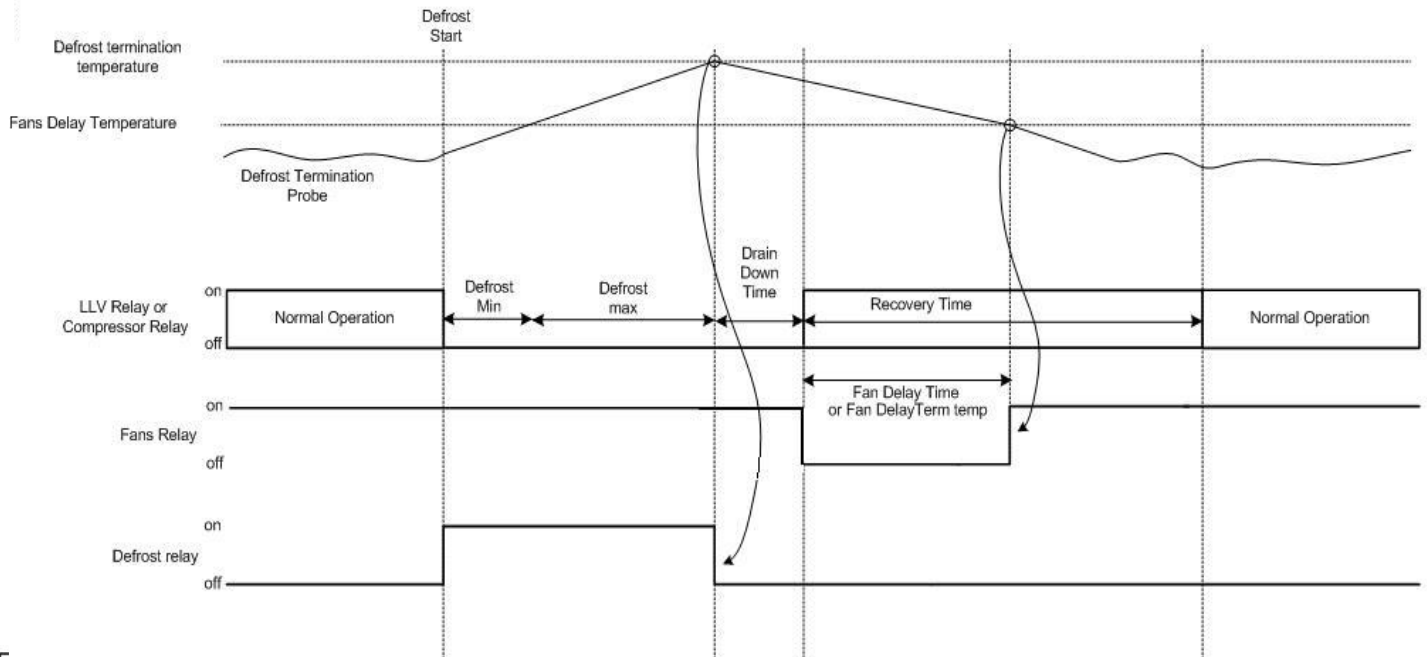

Fans Off in Defrost

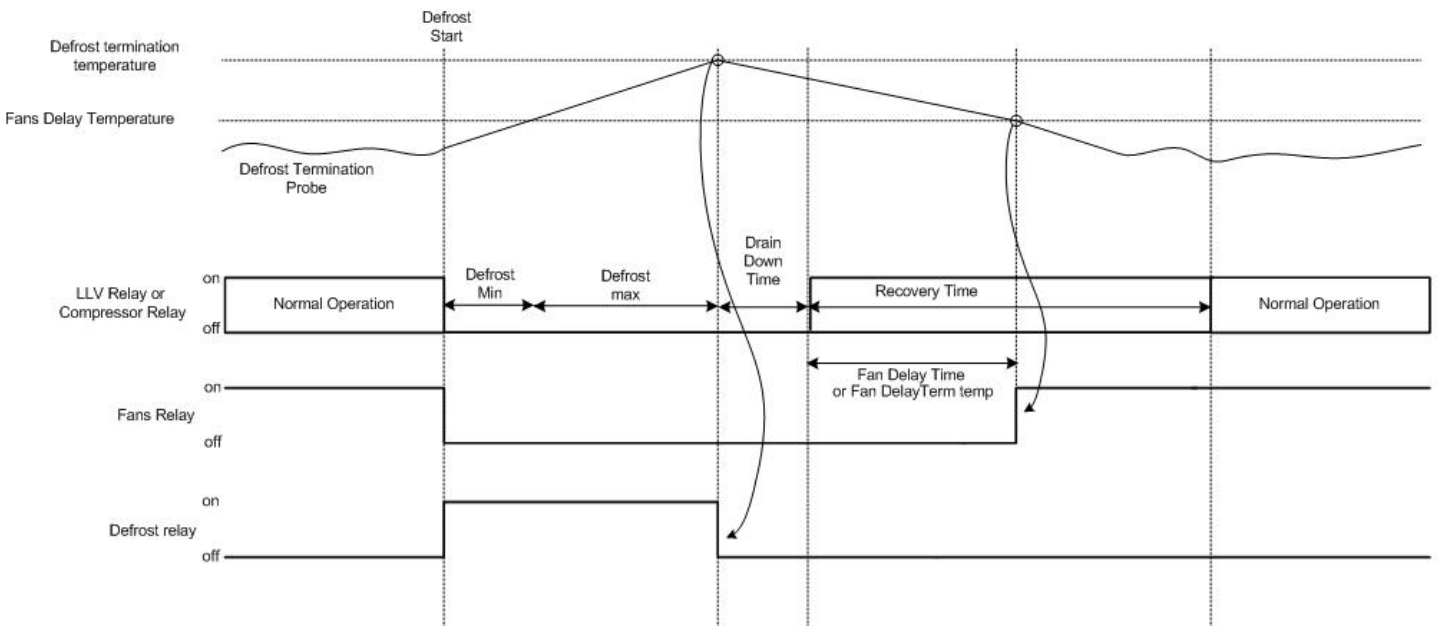

Please ensure all power is switched off before installing or maintaining this product.

Revision History

Revision	Date	Changes
3.0	05/04/2016	Introduction of Mercury Mk3 range
3.0a	22/02/2017	New documentation format.
3.0b	10/04/2014	Added to ECA Energy Technology List.
3.0c	17/05/2017	Operating temperature amended.
3.1	08/09/2017	Plant fault 3 and 4 added, added new parameter Cut In Offset. Support added to allow defrost functionality with remote defrost.
3.2	13/12/17	Alarm weighting parameter added, probe 2 alarm disable parameter added.
3.2a	15/12/17	Spelling mistake corrected in alarm weighting parameter description, used for the OT alarm.
3.2b	30/05/19	I/O table updated, Contact details updated.



Please ensure all power is switched off before installing or maintaining this product.

Group Offices

RDM Group Head Office

80 Johnstone Avenue
Hillington Industrial Estate
Glasgow
G52 4NZ
United Kingdom

+44 (0)141 810 2828
support@resourcedm.com

RDM USA

9441 Science Center Drive
New Hope
MN 55428
United States

+1 612 354 3923
usasupport@resourcedm.com

RDM Asia

Sky Park at One City
Jalan USJ 25/1
47650 Subang Jaya
Selangor
Malaysia

+60 3 5022 3188
asiatech@resourcedm.com



Visit www.resourcedm.com/support for more information on RDM solutions, additional product documentation and software downloads.

While every effort is made to ensure the information given within this document is accurate, Resource Data Management Ltd shall not be liable for errors or omissions, for incidental or consequential damages, directly or indirectly, in connection with the furnishing, performance or misuse of this product or document. All specifications are subject to change without notice.

See www.resourcedm.com for terms and conditions of sales.

Copyright © Resource Data Management