



Resource
Data Management

Mercury 11-10PV Pack Condenser Controller

Commissioning/User Guide
Revision 6.7c



PR0334
PR0332

PR0335
PR0333

Contents

The Mercury Range	4
From Resource Data Management	4
Description	4
Configuration	4
Networks	4
Front Display Panel	5
Section 1 Display	5
Section 2 Display	5
Front Panel Buttons	5
Connections (Mains Version: PR0332 & PR0334)	6
Connections (Low Voltage Version: PR0333 or PR0335)	7
Input/Output Allocation Tables	8
Setting up the controller	9
Set-up through front buttons	9
Set-up Menu for Single Pack controller (Type1)	9
Recommended set-up method	9
Rtc. Real time clock (This will automatically synchronise on network systems)	9
rLy. Set/ View Relay Invert	10
type. Set/view controller type	10
ParA. Set/view parameters	10
Set/View Units	10
Out. Analogue Output	11
OFSt. Temperature Probe Offset	11
Network Configuration	11
485 Legacy module	11
Fast Network Address Reset	12
IP Futura module	12
Parameter Tables	14
Parameter table for Pack Controller (Type 1)	14
Parameter Table for Dual Pack Controller (Type 2)	15
Parameter table for Pack/Condenser Controller (Type 3)	17
Parameter table for Condenser Controller (Type 4)	19
Parameter Descriptions	20
Refrigerant Table	23



Please ensure all power is switched off before installing or maintaining this product.

Configuration of inputs and outputs	24
Stage Inputs	24
Section Stages	24
Stage Sizes	25
Operation	25
Run Times	25
Viewing Inputs and Outputs	25
Input/ Output Tables	25
Input/ Output table for Pack Controller (Type 1)	25
Input/ Output table for Dual Pack Controller (Type 2)	26
Input/ Output table for Pack/Condenser Controller (Type 3)	27
Input/ Output table for Condenser Controller (Type 4)	28
Override	28
Standby Mode	28
Display Messages	28
Network Alarms	29
Specification	30
Power requirements for PR0332 and PR0334:	30
Power requirements for PR0333 and PR0335:	30
General	30
Inputs	30
Analogue Outputs	30
Relay Ratings for PR0332 and PR0334	31
Relay Ratings for PR0333 and PR0335	32
Important Safety Notice:	32
Installation:	33
Panel Cut-out:	33
Fixing:	33
Clearances:	33
Wiring for PR0332 & PR0334:	34
Wiring for PR0333 & PR0335:	35
Cleaning:	35
Appendix 1	36
Typical Transducer Connection	36
Revision History	36



Please ensure all power is switched off before installing or maintaining this product.

The Mercury Range

From Resource Data Management

This documentation refers to the Mercury 11-10PV controller range software version 6.0 or later, manufactured after June 2013.

Description

The Mercury 11-10PV is a versatile controller intended for Pack and Condenser control. It has 10 relay outputs that are configurable for compressors, loaders or fans and a single variable output to control a variable speed device (4-20mA, 0-20mA or 0-10V). The 10 status inputs can be assigned for Pack or Condenser section inputs or general alarms. There are two 4-20mA inputs for pressure transducers and one temperature probe input.

The controller has 4 options; Pack, Dual Pack, Pack and Condenser, and Condenser.

The control is a "Fuzzy logic" based algorithm, giving enhanced control whilst maintaining the starts/ hr requirement. The algorithm also reduces the number of input parameters required for control; only a target pressure is needed.

Like all Mercury controllers, the 11-10PV has a serial output that can connect directly to a PC for quick set-up (PC running RDM Communicator application) or to one of RDMs' network modules. Each relay can switch in excess of 2 Amps. There is an internal or remote display option as well as mains supply versions (100 – 250Vac) or low voltage supply versions (10 - 35 Vdc or 15 - 30 Vac).

There are four variants to choose from:

- PR0332** Mercury 11-10 PV - Mains voltage version with internal display.
- PR0333** Mercury 11-10 PV - Low voltage version with internal display.
- PR0334** Mercury 11-10 PVR - Mains voltage version with Remote display (Inc 5M cable).
- PR0335** Mercury 11-10 PVR -Low voltage version with Remote display (Inc 5M cable).

Configuration

The controller has four configuration options: - (see [Set/View Type](#) for changing the type)

Display value	Type
1	Pack
2	Dual Pack
3	Pack/Condenser
4	Condenser

The controller is delivered pre-configured as a Pack Controller (Type 1).

Networks

The controller is capable of connecting to either a TCP/IP local area network or a RS485 network or controlling in standalone mode with no network output.

To connect to a network you must add the correct communications module. (See [network Configuration](#))

- 485 Legacy module (Part No PR0026)
- IP Futura module (Part No PR0016)

Connecting to either of these communication modules will automatically be detected on power up and this will affect the set up screens made available to you.



Please ensure all power is switched off before installing or maintaining this product.

Front Display Panel

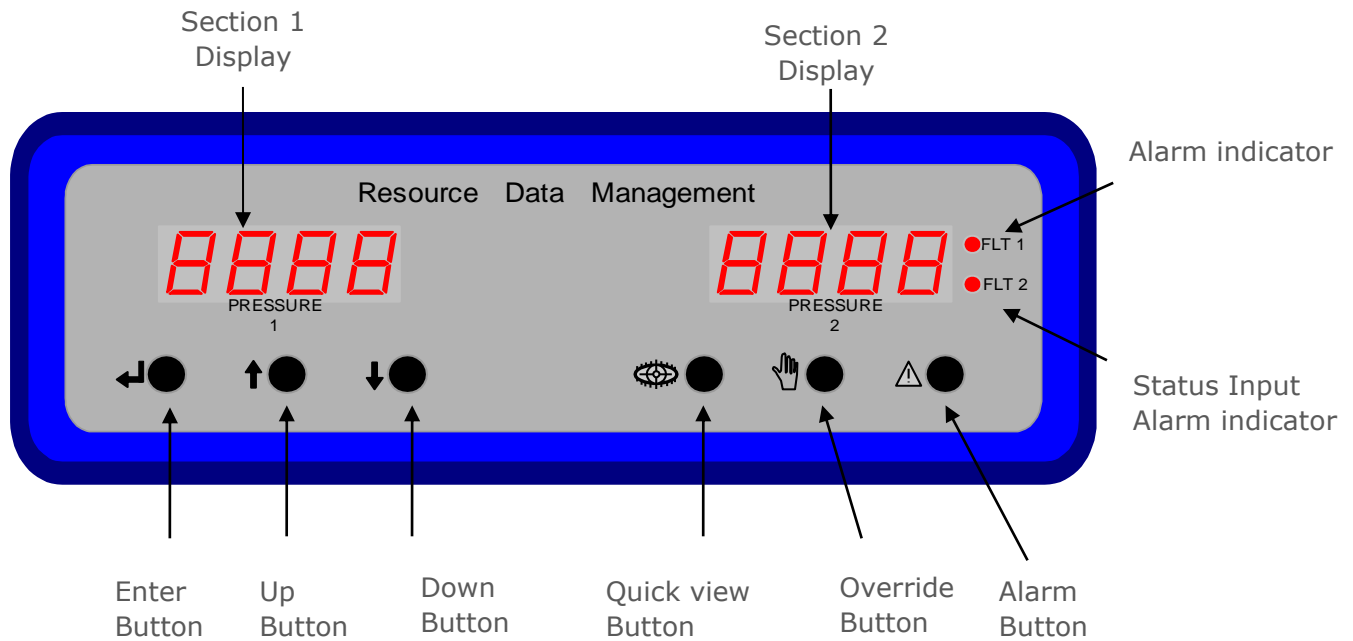

Section 1 Display

4 character display, normally shows the pressure for section 1
 In set-up mode, displays the set-up menu items
 In quick view mode, indicates the target pressure for section 1
 In alarm view mode, indicates the alarm number
 In Override mode, indicates and allows the number of stages of section 1 forced on

Section 2 Display

4 character display, normally shows the pressure for section 2
 In set-up mode, display is blank
 In quick view mode, indicates the target pressure for section 2
 In alarm view mode, indicates the alarm channel (e.g. S101 = section 1 input 1)
 In Override mode, indicates and allows the number of stages of section 2 forced on

Front Panel Buttons

- Enter Button:** - Used to enter menu items.
- Up Button:** - Used to scroll up
- Down Button:** - Used to scroll down
- Quick View Button:** - Used to view the target pressures. Hold for 3 seconds to view, up/ down buttons to go through sections. In "alarm view" mode, used to view the alarm occurred
- Override Button:** - Used with the "Enter" button, to go into the override mode. (See [Override](#) section)
- Alarm Button:** - Used to enter the "alarm view" mode. (See [Display Messages](#) section)



Please ensure all power is switched off before installing or maintaining this product.

Connections (Mains Version: PR0332 & PR0334)

All connections are made to the back of the controller. The diagram below shows the connection detail. Inputs and outputs are assigned according to the chosen configuration. See [Specification](#) and [Wiring](#) for further details on connections.

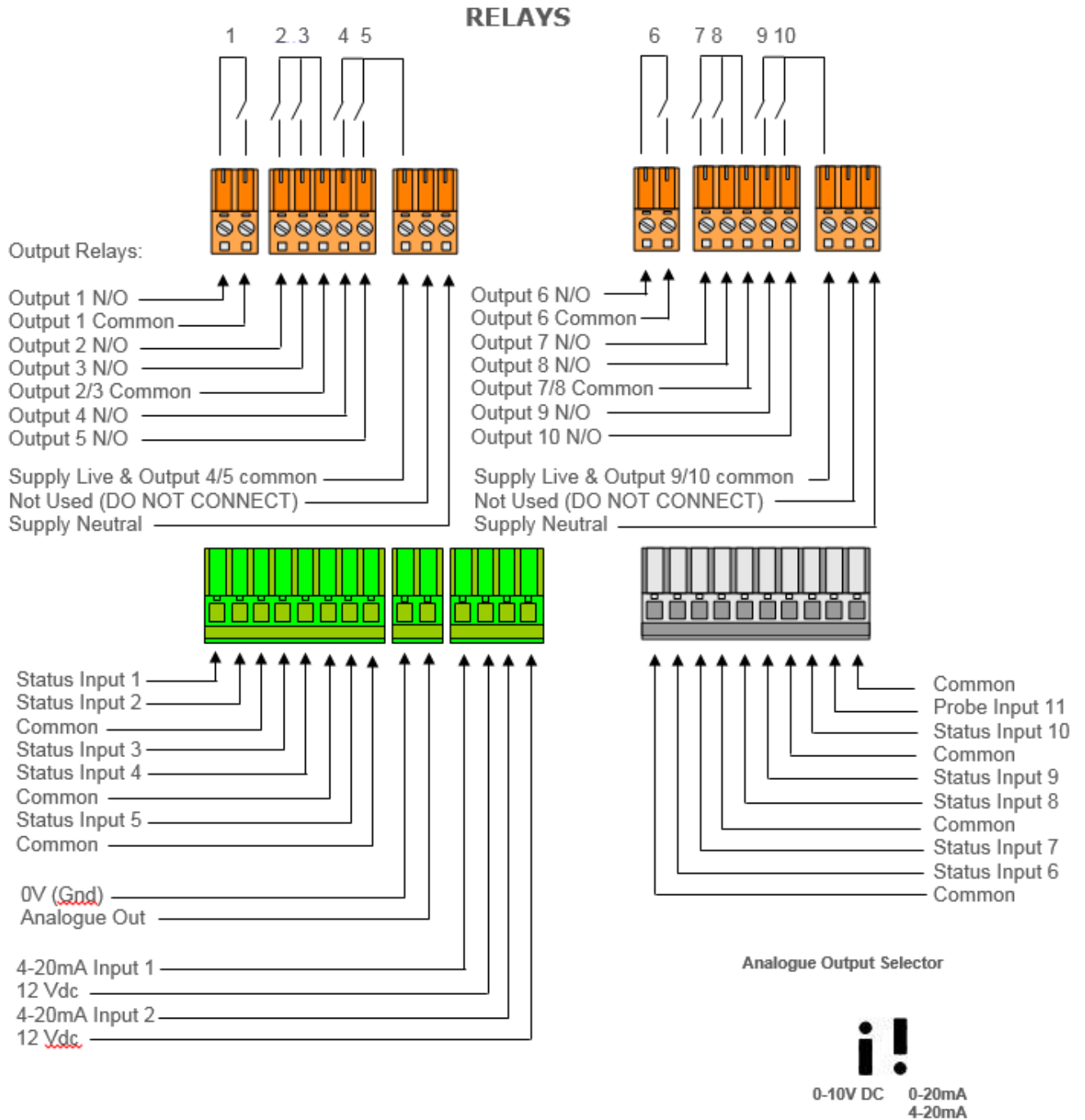

Probe input is PT1000 only.

Both Supplies must be connected.

Do not connect an earth.



Please ensure all power is switched off before installing or maintaining this product.

Connections (Low Voltage Version: PR0333 or PR0335)

All connections are made to the back of the controller. The diagram below shows the connection detail. Inputs and outputs are assigned according to the chosen configuration. See [Specification](#) and [Wiring](#) for further details on connections.

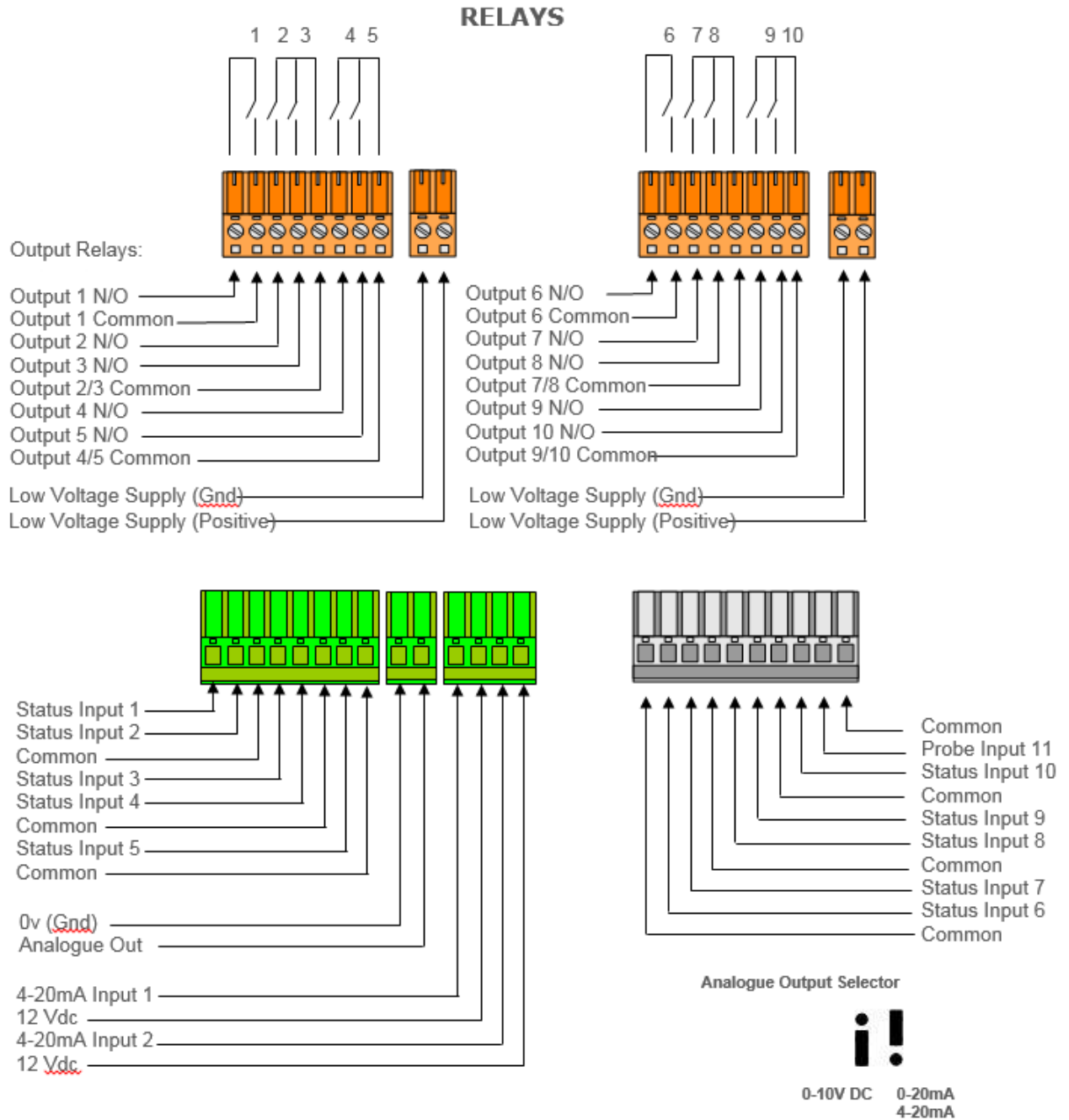

Probe input is PT1000 only.

Both Supplies must be connected.

Low Voltage Supply (Gnd) can be Earthed if required



Please ensure all power is switched off before installing or maintaining this product.

Input/Output Allocation Tables

All Types	Description	Alarm Action	Comments
Status Input 1	0V return	Yes	See note 1 below
Status Input 2	0V return	Yes	
Status Input 3	0V return	Yes	
Status Input 4	0V return	Yes	
Status Input 5	0V return	Yes	
Status Input 6	0V return	Yes	
Status Input 7	0V return	Yes	
Status Input 8	0V return	Yes	
Status Input 9	0V return	Yes	
Status Input 10	0V return	Yes	
Probe Input 11	PT1000 Temperature	No	For monitoring or floating head pressure control.
Standby Input	Puts the controller into standby	Yes	590 Ohm resistor on Probe I/P See Standby Mode
4-20mA Input 1	Section 1 Pressure transducer	Yes	See note 3 below
4-20mA Input 2	Section 2 Pressure transducer	Yes	See note 3 below
Analogue Output	Variable voltage / current Output	N/A	See note 4 below
Relay 1	N/O	N/A	See note 2 below
Relay 2	N/O	N/A	
Relay 3	N/O	N/A	
Relay 4	N/O	N/A	
Relay 5	N/O	N/A	
Relay 6	N/O	N/A	
Relay 7	N/O	N/A	
Relay 8	N/O	N/A	
Relay 9	N/O	N/A	
Relay 10	N/O	N/A	

Note 1: Status inputs are configured as either "stage" inputs or as "general" depending on the set-up. Status inputs can be configured as "normally open" or "normally closed".

Note 2: All relay outputs are normally open. The functional allocation depends on the set-up parameters.

Note 3: Pressure transducers must be of the current loop 4-20mA type. Excitation voltage (12 Vdc) is provided for each transducer input.

Note 4: This output is selectable, either 0-10V DC or 0-20mA / 4-20mA.



Please ensure all power is switched off before installing or maintaining this product.

Setting up the controller

Set-up access to the controller can be achieved several ways;

- Through the front mounted buttons
- Direct access by PC into the rear comms port. This requires a software package available on the RDM website (Communicator)
- Through legacy front end panels on 485 networks
- Through the RDM Data Manager.

Set-up through front buttons

To enter set-up mode, hold the Enter and Down buttons together for approximately 3 seconds until the message "Ent" appears on the display. Now press the Enter button again to enter the function menu. IO will be displayed. Scroll up or down to go through the list.

Set-up Menu for Single Pack controller (Type1)

LH Display	RH Display	Option	Menu Item seen in type:	Explained in Paragraph
IO		View Input/Output States	All types	View Input/Output States
ParA		Set/view Parameters	All types	Set/view parameters
Unit		Set/View units	All types	Set/View Units
Type		Set/View Controller Type	All types	Set/view product type
rLy		Set/View Relay Invert	All types	Set/View Relay Invert
Out		Set 0-20mA or 4-20mA	All types	Set Out
rtc		Set/view Clock (rtc = Real Time Clock)	All types	Real Time Clock
nEt		Set/view network configuration	All types	Network Configuration
SoFt		View software version	All types	
OFSt		Temperature probe Calibration (C-06)	All Types	Probe Offset
ESC		Exit set-up mode		

Recommended set-up method

If you are not connecting to a network and want to set up the controller through the buttons we recommend you use the following order from the function menu.

Rtc. Real time clock (This will automatically synchronise on network systems)

1. Use the up or down buttons to scroll through the display until the display reads "rtc"
2. Press enter. The display will show "t-1". Press enter again
3. Scroll hours up or down (0 – 23) press enter
4. Use up button to select "t-2", press enter
5. Scroll minutes up or down (0 – 59) press enter
6. Repeat for t-3 (seconds 0 – 59)
7. Repeat for t-4 (days up to 31)
8. Repeat for t-5 (months up to 12)
9. Repeat for t-6 (year up to 99)
10. Use up button to display "ESC", press enter to display "rtc"

Time clock is now set



Please ensure all power is switched off before installing or maintaining this product.

rLy. Set/ View Relay Invert

When enabled this feature will invert all relay operation on the controller e.g. if relay 1 is off and the relay invert feature is enabled it will invert the relay to on. This feature affects all relays on the controller.

- 0 = Normal Relay Operation (Default)
- 1 = Inverted Relay Operation

type. Set/view controller type

1. From the function menu scroll to "type", press enter
2. Use the up/down buttons to scroll through the type values. (See [configuration](#) on page 4)
3. Press enter.

The controller will reset with the selected type now programmed.

ParA. Set/view parameters

(We recommend setting parameters from "Communicator" or the network front end such as "Data Manager")

1. From the function menu scroll to ParA
2. Pressing Enter while ParA is displayed will enter the parameter menu.

The first parameter option will be displayed as P-01. Pressing the Up or Down button will present the other parameter options P-02, P-03 etc. See the parameter list below to find what parameter number corresponds to which actual parameter.

Pressing the Enter button will show the current value of the selected parameter. Press Up or Down to modify the value and press Enter again to save the value. The parameter list number will be displayed again.

Two other options are present in the parameter menu – **dFLt** and **ESC**. Selecting ESC will exit the parameter set-up mode. Selecting dFLt will reset all parameters back to the default values for the current controller type.

See [Parameter Tables](#) for values.

Set/View Units

This option allows the user to set the pressure units to either PSI or BAR. The user can also select an option to display the condenser probe temperature (if used) in °F.

- 0 = Bar / °C (default)
- 1 = Bar / °F
- 2 = Psi / °C
- 3 = Psi / °F

Once activated, the controller parameters and display units will be in the set units. Note. If using the controller on a Genus system, bar units will not display on the system front-end.

Note: - If the units are set to PSI °C or BAR °C then on the event of a pressure transducer probe failure, on a pack section, all compressor and loader stages are turned **off**. If the units are set to PSI °F or BAR °F then in the event of a pressure transducer probe failure, on a pack section, all compressor and loader stages are turned **on**.



Please ensure all power is switched off before installing or maintaining this product.

Out. Analogue Output

From the controller software menu select "Out".

If link is in 0-20mA/4-20mA position then the following applies: - 0 = 0-20mA 1 = 4-20mA

If link in 0-10 V position then Out must be set to 0: - 0 = 0-10V 1 = should not be used.

The range of the transducer will vary according to the application, this can be set to match the transducer by changing the "[span and offset](#)" in the controller parameters.

OFSt. Temperature Probe Offset.

This allows the temperature probe reading to be offset to compensate for resistance drops due to long cable runs.

1. From the function menu scroll to "OFSt", press enter
2. Use the up/down buttons to scroll through the probe inputs C-01 to C-06, in this controller only probe 6 is used (C-06)
3. Press enter to select C-06, the current offset is shown, press the up and down buttons to adjust
4. Press enter to save.

Network Configuration

The final section to setup is the network address. In all instances, this must be done before the controller is connected to the site network.

To set the controller onto a network you must first connect the controller to a communications module. This is either:

- A 485 Legacy module or
- An IP Futura module
- An IP Mercury Hub

485 Legacy module

Using RS485, the controllers have an auto-initialise function, which will automatically log the device onto the site network. If the wrong address has been entered onto the network, you will have to reset the controller address by setting the address to 00-0, and then re-enter the correct address (you may have to deregister the wrong address from the home system as well).

Connecting an RS485 legacy Module to the controller will govern which set up screens are made available in the 'Net' menu. The modules support the "Genus" protocol only. Using RS485 will show the below;

Display	Option
485t	485 Network Type
485A	485 Address/Name
gAdd	Show underlying network address assigned to controller
rLog	Re-log the controller back onto the network
CLrA	Clear the address/name from the controller
ESC	Exit network menu. N.B. this option must be selected to save any changes made in this menu

The **485t** option shows a value representing the network type. The possible values are:

Value	Network Type
1	Genus compatible (all versions)
2	Wireless Mesh (not available)



Please ensure all power is switched off before installing or maintaining this product.

Ensure option '1' is selected.

The **485A** option shows a value representing the name of the controller in a Genus compatible network. For example, if the value shown in 485A is shown as "05-6". The controller would try to log onto a Genus compatible network using the name 'RC05-6'.

The **gAdd** option displays (in hexadecimal format) the underlying network address assigned to the controller when it was logged onto the network. NB this is automatically assigned by the Data Manager.

The **rLog** option allows the controller to be logged back onto the network with its current name. The 'rLog' message will flash, waiting for confirmation. To confirm, press the Enter button to execute the command, Up or Down buttons to cancel.

The **CLrA** option will clear out the network address and name in the controller. The 'CLrA' message will flash for confirmation. Press the Enter button to execute the command, Up or Down buttons to cancel.

Fast Network Address Reset

To enter this mode, hold the Enter, Up and Down buttons together for approximately 3 seconds until the message CLrA appears on the display. CLrA is the first option in the menu consisting of the following options:

Display	Option
CLrA	Clear the address/name from the controller
ESC	Exit Setup mode

Pressing the Enter button to select the CLrA option will cause the 'CLrA' message to flash for confirmation, if the network type is set to Genus compatible. Press the Enter button to execute the command, Up or Down buttons to cancel. If the network type is not set to Genus compatible then the CLrA message will not flash and the ESC option can be used to exit the menu.

IP Futura module

In an IP system there are two options;

- IP-L
- IP-r

IP-L allows you to fix an IP address into the controller, which you would use when you are connecting the controllers onto a customer's local area network. This would allow the customer to view each controller using a generic Internet browser.

IP-r allows you to give each controller on the system a unique number (using the rotary switches). This number is then allocated a dynamic IP address by the system's DHCP server (such as the RDM Data Manager).



Please ensure all power is switched off before installing or maintaining this product.

IP-L

To configure the communication module for IP-L, set all three rotary switches to zero. The module should then be connected to the controller.

- From the function menu you can now select 'nEt'.
- Press enter and the display will show "IP-L", press enter once more.
- You can now set the IP network settings by using the table below

Display	Option
IP-1	IP Address byte 1
IP-2	IP Address byte 2
IP-3	IP Address byte 3
IP-4	IP Address byte 4
nL	Network Mask Length (see below table)
gt-1	Gateway Address byte 1
gt-2	Gateway Address byte 2
gt-3	Gateway Address byte 3
gt-4	Gateway Address byte 4
ESC	Exit network menu. N.B. this option must be selected to save any changes made in this menu

IP-r

To configure the communication module for IP-r, set the three rotary switches to give each controller a unique identifier. The module should then be connected to the controller and the network.

- From the function menu you can now select 'nEt'
- Press enter and the display will show "IP-r", press enter once more
- You can now view (only) the address given by the DHCP server

To ease setup, a single network mask length value is used. If the address has been specified with a network mask value in dotted IP format e.g. 255.255.255.0 then the table below gives the conversion:

Mask	Length	Mask	Length	Mask	Length
		255.255.254.0	23	255.254.0.0	15
255.255.255.252	30	255.255.252.0	22	255.252.0.0	14
255.255.255.248	29	255.255.248.0	21	255.248.0.0	13
255.255.255.240	28	255.255.240.0	20	255.240.0.0	12
255.255.255.224	27	255.255.224.0	19	255.224.0.0	11
255.255.255.192	26	255.255.192.0	18	255.192.0.0	10
255.255.255.128	25	255.255.128.0	17	255.128.0.0	09
255.255.255.0	24	255.255.0.0	16	255.0.0.0	08



Please ensure all power is switched off before installing or maintaining this product.

Parameter Tables

Parameter table for Pack Controller (Type 1)

Number	Parameter	Range	Step	Units	Default
P-01	Section 1 Transducer Span*	-3.4 – 50.0	0.1	Bar (Psi)	13.8
P-02	Section 1 Transducer Offset*	-3.4 – 50.0	0.1	Bar (Psi)	0
P-03	Section 1 Day Target	-3.4 – 50.0	0.1	Bar (Psi)	2.1
P-04	Section 1 Night Target	-3.4 – 50.0	0.1	Bar (Psi)	2.1
P-05	Section 1 Equalise Run Times	0 = off, 1 = on	1		0
P-06	Section 1 Diff Above Target	-3.4 – 50.0	0.1	Bar (Psi)	0.5
P-07	Section 1 Diff Below Target	-3.4 – 50.0	0.1	Bar (Psi)	0.5
P-08	Section 1 Starts Per Hour	0 – 60	1		6
P-09	Section 1 Run Smallest **	0 = off, 1 = on	1		0
P-10	Section 1 Always Run Last	0 = off, 1 = on	1		0
P-11	Section 1 Inverter	0 = off, 1 = on	1		0
P-12	Section 1 Response On Speed	1 – 60	1		5
P-13	Section 1 Response Off Speed	1 – 60	1		5
P-29	Section 1 Time Constant	Not used at present			
P-14	Section 1 Optimise Limit	-3.4 – 50.0	0.1	Bar (Psi)	2
P-21	Section 1 Night Setback Start Time	00:00 – 23:59	00.01	hh:mm	20:00
P-22	Section 1 Night Setback Stop Time	00:00 – 23:59	00:01	hh:mm	08:00
P-82	Section 1 Alarm Delay	00:00 – 99:00	01:00	mm:ss	05:00
P-81	Section 1 LP Shutdown Delay	00:00 – 99:00	01:00	mm:ss	00:00
P-83	Section 1 HP Alarm	-3.4 – 50.0	0.1	Bar (Psi)	4.1
P-84	Section 1 LP Alarm	-3.4 – 50.0	0.1	Bar (Psi)	0.6
P-85	S1 LP Shutdown	-3.4 – 50.0	0.1	Bar (Psi)	0.4
P-122	Status Fault Delay	00:00 – 60:00	00:10	mm:ss	00:10
P-123	General Fault Delay	00:00 – 60:00	00:10	mm:ss	00:10
P-131 ↓ P-140	Stage 1 Input Type *** ↓ Stage 10 Input Type	0 = Unused 1 = Stage N/O 2 = Stage N/C 3 = General N/O 4 = General N/C			0
P-201 ↓ P-210	Stage 1 Output Type ↓ Stage 10 Output Type	0 = None 1 = Unused 2 = Inverter 3 = Compressor 4 = Loader 5 = Fan	1		0
P-251 ↓ P-260	Section 1 Compressor Size ↓ Section 10 Compressor Size	0 – 60	0.1		0
dFLt	Restore Default Settings				
Esc	Exit Menu				

* Span and Offset allows for the full range of the transducer to be used by the controller.
Span is the full range of the transducer
Offset is the value below zero.

Example: Danfoss AKS 33 with range: -1 bar to 12 bar



Please ensure all power is switched off before installing or maintaining this product.

Span would be 190 (13 bar)
Offset would be -15 (-1 bar)

Run smallest=on:- When all compressors are off (because the target pressure has been satisfied) the controller, when the pressure rises, will always turn on the smallest compressor. If the ASC timer is running for the smallest compressor, the controller will **NOT bring on any other available compressors, it will wait until the ASC timer has elapsed and turn on the smallest.
Please note that this is true for **any** pressure condition.

*** Stage inputs have a pre-programmed delay of 10 seconds, this cannot be changed.

Parameter Table for Dual Pack Controller (Type 2)

Number	Parameter	Range	Step	Units	Default
P-01	Section 1 Transducer Span*	-3.4 - 50.0	0.1	Bar (Psi)	13.8
P-02	Section 1 Transducer Offset*	-3.4 - 50.0	0.1	Bar (Psi)	0
P-03	Section 1 Day Target	-3.4 - 50.0	0.1	Bar (Psi)	2.1
P-04	Section 1 Night Target	-3.4 - 50.0	0.1	Bar (Psi)	2.1
P-05	Section 1 Equalise Run Times	0 = off, 1 = on	1		0
P-06	Section 1 Diff Above Target	-3.4 - 50.0	0.1	Bar (Psi)	0.5
P-07	Section 1 Diff Below Target	-3.4 - 50.0	0.1	Bar (Psi)	0.5
P-08	Section 1 Starts Per Hour	0 - 60	1		6
P-09	Section 1 Run Smallest **	0 = off, 1 = on	1		0
P-10	Section 1 Always Run Last	0 = off, 1 = on	1		0
P-11	Section 1 Inverter	0 = off, 1 = on	1		0
P-12	Section 1 Response On Speed	1 - 60	1		5
P-13	Section 1 Response Off Speed	1 - 60	1		5
P-29	Section 1 Time Constant	Not used at present			
P-14	Section 1 Optimise Limit	-3.4 - 50.0	0.1	Bar (Psi)	2
P-21	Section 1 Night Setback Start Time	00:00 - 23:59	00.01	hh:mm	20:00
P-22	Section 1 Night Setback Stop Time	00:00 - 23:59	00:01	hh:mm	08:00
P-41	Section 2 Transducer Span*	-3.4 - 50.0	0.1	Bar (Psi)	13.8
P-42	Section 2 Transducer Offset*	-3.4 - 50.0	0.1	Bar (Psi)	0
P-43	Section 2 Day Target	-3.4 - 50.0	0.1	Bar (Psi)	2.1
P-44	Section 2 Night Target	-3.4 - 50.0	0.1	Bar (Psi)	2.1
P-45	Section 2 Equalise Run Times	0 = off, 1 = on	1		0
P-46	Section 2 Diff Above Target	-3.4 - 50.0	0.1	Bar (Psi)	0.5
P-47	Section 2 Diff Below Target	-3.4 - 50.0	0.1	Bar (Psi)	0.5
P-48	Section 2 Starts Per Hour	0 - 60	1		6
P-49	Section 2 Run Smallest **	0 = off, 1 = on	1		0
P-50	Section 2 Always Run Last	0 = off, 1 = on	1		0
P-51	Section 2 Inverter	0 = off, 1 = on	1		0
P-52	Section 2 Response On Speed	1 - 60	1		5
P-53	Section 2 Response Off Speed	1 - 60	1		5
P-69	Section 2 Time Constant	Not used at present			
P-54	Section 2 Optimise Limit	-3.4 - 50.0	0.1	Bar (Psi)	2
P-61	Section 2 Night Setback Start Time	00:00 - 23:59	00.01	hh:mm	20:00
P-62	Section 2 Night Setback Stop Time	00:00 - 23:59	00:01	hh:mm	08:00
P-82	Section 1 Alarm Delay	00:00 - 99:00	01:00	mm:ss	05:00
P-81	Section 1 LP Shutdown Delay	00:00 - 99:00	01:00	mm:ss	00:00
P-83	Section 1 HP Alarm	-3.4 - 50.0	0.1	Bar (Psi)	4.1



Please ensure all power is switched off before installing or maintaining this product.

Number	Parameter	Range	Step	Units	Default
P-84	Section 1 LP Alarm	-3.4 – 50.0	0.1	Bar (Psi)	0.6
P-85	S1 LP Shutdown	-3.4 – 50.0	0.1	Bar (Psi)	0.4
P-102	Section 2 Alarm Delay	00:00 – 99:00	01:00	mm:ss	05:00
P-101	Section 2 LP Shutdown Delay	00:00 – 99:00	01:00	mm:ss	00:00
P-103	Section 2 HP Alarm	-3.4 – 50.0	0.1	Bar (Psi)	4.1
P-104	Section 2 LP Alarm	-3.4 – 50.0	0.1	Bar (Psi)	0.6
P-105	S2 LP Shutdown	-3.4 – 50.0	0.1	Bar (Psi)	0.4
P-122	Status Fault Delay	00:00 – 60:00	00:10	mm:ss	00:10
P-123	General Fault Delay	00:00 – 60:00	00:10	mm:ss	00:10
P-131	Stage 1 Input Type ***	0 = Unused 1 = Stage N/O 2 = Stage N/C 3 = General N/O 4 = General N/C	1		0
↓	↓				
P-140	Stage 10 Input Type				
P-201	Section 1 Stage 1 Output Type	0 = None 1 = Unused 2 = Inverter 3 = Compressor 4 = Loader 5 = Fan	1		0
↓	↓				
P-210	Section 1 Stage 10 Output Type				
P-301	Section 2 Stage 1 Output Type	0 = None 1 = Unused 2 = Inverter 3 = Compressor 4 = Loader 5 = Fan	1		0
↓	↓				
P-310	Section 2 Stage 10 Output Type				
P-251	Section 1 Stage 1 Compressor Size	0 – 60	0.1		0
↓	↓				
P-260	Section 1 Stage 10 Compressor Size				
P-351	Section 2 Stage 1 Compressor Size	0 – 60	0.1		0
↓	↓				
P-360	Section 2 Stage 10 Compressor Size				
dFLt	Restore Default Settings				
Esc					

* Span and Offset allows for the full range of the transducer to be used by the controller.

Span is the full range of the transducer

Offset is the value below zero.

Example: Danfoss AKS 33 with range: -1 bar to 12 bar
Span would be 190 (13 bar)
Offset would be -15 (-1 bar)

Run smallest=on:- When all compressors are off (because the target pressure has been satisfied) the controller, when the pressure rises, will always turn on the smallest compressor. If the ASC timer is running for the smallest compressor, the controller will **NOT bring on any other available compressors, it will wait until the ASC timer has elapsed and turn on the smallest.

Please note that this is true for **any** pressure condition.

*** Stage inputs have a pre-programmed delay of 10 seconds, this cannot be changed.



Please ensure all power is switched off before installing or maintaining this product.

Parameter table for Pack/Condenser Controller (Type 3)

Number	Parameter	Range	Step	Units	Default
P-01	Section 1 Transducer Span*	-3.4 – 50.0	0.1	Bar (Psi)	13.8
P-02	Section 1 Transducer Offset*	-3.4 – 50.0	0.1	Bar (Psi)	0
P-03	Section 1 Day Target	-3.4 – 50.0	0.1	Bar (Psi)	2.1
P-04	Section 1 Night Target	-3.4 – 50.0	0.1	Bar (Psi)	2.1
P-05	Section 1 Equalise Run Times	0 = off, 1 = on	1		0
P-06	Section 1 Diff Above Target	-3.4 – 50.0	0.1	Bar (Psi)	0.5
P-07	Section 1 Diff Below Target	-3.4 – 50.0	0.1	Bar (Psi)	0.5
P-08	Section 1 Starts Per Hour	0 – 60	1		6
P-09	Section 1 Run Smallest **	0 = off, 1 = on	1		0
P-10	Section 1 Always Run Last	0 = off, 1 = on	1		0
P-11	Section 1 Inverter	0 = off, 1 = on	1		0
P-12	Section 1 Response On Speed	1 – 60	1		5
P-13	Section 1 Response Off Speed	1 – 60	1		5
P-29	Section 1 Time Constant	Not used at present			
P-14	Section 1 Optimise Limit	-3.4 – 50.0	0.1	Bar (Psi)	2
P-15	Section 1 Discharge Trip Interlock	0 = off, 1 = on	1		0
P-21	Section 1 Night Setback Start Time	00:00 – 23:59	00.01	hh:mm	20:00
P-22	Section 1 Night Setback Stop Time	00:00 – 23:59	00:01	hh:mm	08:00
P-41	Section 2 Transducer Span*	-3.4 – 50.0	0.1	Bar (Psi)	13.8
P-42	Section 2 Transducer Offset*	-3.4 – 50.0	0.1	Bar (Psi)	0
P-43	Section 2 Day Target	-3.4 – 50.0	0.1	Bar (Psi)	2.1
P-44	Section 2 Night Target	-3.4 – 50.0	0.1	Bar (Psi)	2.1
P-46	Section 2 Diff Above Target	-3.4 – 50.0	0.1	Bar (Psi)	0.5
P-47	Section 2 Diff Below Target	-3.4 – 50.0	0.1	Bar (Psi)	0.5
P-51	Section 2 Inverter	0 = off, 1 = on	1		0
P-52	Section 2 Response On Speed	1 – 60	1		5
P-53	Section 2 Response Off Speed	1 – 60	1		5
P-69	Section 2 Time Constant	Not used at present			
P-56	Section 2 Discharge Trip	-3.4 – 50.0	0.1	Bar (Psi)	15
P-57	Section 2 Discharge Stop	-3.4 – 50.0	0.1	Bar (Psi)	18
P-58	Section 2 Discharge Offset	-3.4 – 50.0	0.1	Bar (Psi)	2
P-59	Section 2 Night Setback	0 = off, 1 = on	1		0
P-60	Section 2 Night Reduction	0 – 100	1	%	30
P-61	Section 2 Night Setback Start Time	00:00 – 23:59	00:01	hh:mm	20:00
P-62	Section 2 Night Setback End Time	00:00 – 23:59	00:01	hh:mm	08:00
P-63	Section 2 Night Pressure Limit	-3.4 – 50.0	0.1	Bar (Psi)	25
P-64	Section 2 Day Reduction	0 – 100	1	%	0
P-65	Section 2 Day Pressure Limit	-3.4 – 50.0	0.1	Bar (Psi)	25
P-66	Section 2 Control Type	0 = Fixed, 1 = Floating	1		0
P-67	Condenser Offset	0 – 20	0.1	C (F)	6
P-70	Section 2 Refrigerant Type	0 – 29	1		0



Please ensure all power is switched off before installing or maintaining this product.

Number	Parameter	Range	Step	Units	Default
P-71	Section 2 Pressure Type	0 = Absolute, 1 = Gauge	1		1
P-72	Section 2 Low Pressure Limit	-3.4 – 50	0.1	Bar (Psi)	8.2
P-73	Section 2 High Pressure Limit	-3.4 – 50	0.1	Bar (Psi)	23
P-82	Section 1 Alarm Delay	00:00 – 99:00	01:00	mm:ss	05:00
P-81	Section 1 LP Shutdown Delay	00:00 – 99:00	01:00	mm:ss	00:00
P-83	Section 1 HP Alarm	-3.4 – 50.0	0.1	Bar (Psi)	4.1
P-84	Section 1 LP Alarm	-3.4 – 50.0	0.1	Bar (Psi)	0.6
P-85	S1 LP Shutdown	-3.4 – 50.0	0.1	Bar (Psi)	0.4
P-102	Section 2 Alarm Delay	00:00 – 99:00	01:00	mm:ss	05:00
P-101	Section 2 LP Shutdown Delay	00:00 – 99:00	01:00	mm:ss	00:00
P-103	Section 2 HP Alarm	-3.4 – 50.0	0.1	Bar (Psi)	17.9
P-104	Section 2 LP Alarm	-3.4 – 50.0	0.1	Bar (Psi)	6.8
P-105	S2 LP Shutdown	-3.4 – 50.0	0.1	Bar (Psi)	6.2
P-122	Status Fault Delay	00:00 – 60:00	00:10	mm:ss	00:10
P-123	General Fault Delay	00:00 – 60:00	00:10	mm:ss	00:10
P-131	Stage 1 Input Type ***	0 = Unused 1 = Stage N/O 2 = Stage N/C 3 = General N/O 4 = General N/C	1		0
P-140	Stage 10 Input Type				
P-201	Section 1 Stage 1 Output Type	0 = None 1 = Unused 2 = Inverter 3 = Compressor 4 = Loader 5 = Fan	1		0
P-210	Section 1 Stage 10 Output Type				
P-301	Section 2 Stage 1 Output Type	0 = None 1 = Unused 2 = Inverter 3 = Compressor 4 = Loader 5 = Fan	1		0
P-310	Section 2 Stage 10 Output Type				
P-251	Section 1 Stage 1 Compressor Size	0 – 60	0.1		0
P-260	Section 1 Stage 10 Compressor Size				
dFLt	Restore Default Settings				
Esc					

* Span and Offset allows for the full range of the transducer to be used by the controller.
Span is the full range of the transducer
Offset is the value below zero.

Example: Danfoss AKS 33 with range: -1 bar to 12 bar
Span would be 190 (13 bar)
Offset would be -15 (-1 bar)

Run smallest=on:- When all compressors are off (because the target pressure has been satisfied) the controller, when the pressure rises, will always turn on the smallest compressor. If the ASC timer is running for the smallest compressor, the controller will **NOT bring on any other available compressors, it will wait until the ASC timer has elapsed and turn on the smallest.
Please note that this is true for **any** pressure condition.

*** Stage inputs have a pre-programmed delay of 10 seconds, this cannot be changed.



Please ensure all power is switched off before installing or maintaining this product.

Parameter table for Condenser Controller (Type 4)

Number	Parameter	Range	Step	Units	Default
P-01	Section 1 Transducer Span*	-3.4 – 50.0	0.1	Bar (Psi)	34.4
P-02	Section 1 Transducer Offset*	-3.4 – 50.0	0.1	Bar (Psi)	0
P-03	Section 1 Day Target	-3.4 – 50.0	0.1	Bar (Psi)	12.7
P-04	Section 1 Night Target	-3.4 – 50.0	0.1	Bar (Psi)	12.7
P-05	Section 1 Equalise Run Times	0 = off, 1 = on	1		0
P-06	Section 1 Diff Above Target	-3.4 – 50.0	0.1	Bar (Psi)	0.5
P-07	Section 1 Diff Below Target	-3.4 – 50.0	0.1	Bar (Psi)	0.5
P-11	Section 1 Inverter	0 = off, 1 = on	1		0
P-12	Section 1 Response On Speed	1 – 60	1		5
P-13	Section 1 Response Off Speed	1 – 60	1		5
P-29	Section 1 Time Constant	Not used at present			
P-19	Section 1 Night Setback	0=off, 1=on, 2=local, 3=remote			0
P-20	Section 1 Night Setback Reduction	0-100	1	%	30
P-21	Section 1 Night Setback Start Time	00:00 – 23:59	00.01	hh:mm	20:00
P-22	Section 1 Night Setback Stop Time	00:00 – 23:59	00:01	hh:mm	08:00
P-23	Section 1 Night Setback Pressure Limit	-3.4 – 50.0	0.1	Bar (Psi)	25
P-24	Section 1 Day Reduction	0-100	1	%	0
P-25	Section 1 Day Pressure Limit	-3.4 – 50.0	0.1	Bar (Psi)	25
P-26	Section 1 Control Type	0=fixed, 1=floating	1		0
P-27	Section 1 Condenser Offset	0-20	0.1	C (F)	6
P-70	Section 1 Refrigerant Type	0 – 29	1		0
P-71	Section 1 Pressure Type	0=Absolute, 1=Gauge	1		1
P-72	Section 1 Low Pressure Limit	-3.4 – 50	0.1	Bar (Psi)	8.2
P-73	Section 1 High Pressure Limit	-3.4 – 50	0.1	Bar (Psi)	23
P-82	Section 1 Alarm Delay	00:00 – 99:00	01:00	mm:ss	05:00
P-81	Section 1 LP Shutdown Delay	00:00 – 99:00	01:00	mm:ss	00:00
P-83	Section 1 HP Alarm	-3.4 – 50.0	0.1	Bar (Psi)	4.1
P-84	Section 1 LP Alarm	-3.4 – 50.0	0.1	Bar (Psi)	0.6
P-85	S1 LP Shutdown	-3.4 – 50.0	0.1	Bar (Psi)	0.4
P-122	Status Fault Delay	00:00 – 60:00	00:10	mm:ss	00:10
P-123	General Fault Delay	00:00 – 60:00	00:10	mm:ss	00:10
P-131	Stage 1 Input Type ***	0 = Unused 1 = Stage N/O 2 = Stage N/C 3 = General N/O 4 = General N/C			0
P-140	Stage 10 Input Type				
P-201	Stage 1 Output Type	0 = None 1 = Unused 2 = Inverter 3 = Compressor 4 = Loader 5 = Fan	1		0
P-210	Stage 10 Output Type				
dFLt	Restore Default Settings				
Esc					



Please ensure all power is switched off before installing or maintaining this product.

* Span and Offset allows for the full range of the transducer to be used by the controller.
Span is the full range of the transducer
Offset is the value below zero.

Example: Danfoss AKS 33 with range: -1 bar to 12 bar
Span would be 190 (13 bar)
Offset would be -15 (-1 bar)

*** Stage inputs have a pre-programmed delay of 10 seconds, this cannot be changed.

Parameter Descriptions

Number	Parameter	Description
P-01	Section 1 Transducer Span*	Range of the transducer.
P-02	Section 1 Transducer Offset*	Transducer value above or below zero.
P-03	Section 1 Day Target	Pressure target, control will try to maintain this pressure during the day, subject to times set on P-21 & P-22
P-04	Section 1 Night Target	Pressure target, control will try to maintain this pressure during the night, subject to times set on P-21 & P-22
P-05	Section 1 Equalise Run Times	When set to 1 (On) the controller will bring on the compressors in a way that the running times are as near equal as possible. If the pressure is above set point the next compressor that comes on will be the compressor that has been running for the least amount of time. If the pressure is below set point the next compressor to go off will be the one that has been running the longest. This configuration will try to make each compressors run hours equal
P-06	Section 1 Diff Above Target	Set-point above the target, used to obtain a "dead-band" when using an inverter drive
P-07	Section 1 Diff Below Target	Set-point below the target, used to obtain a "dead-band" when using an inverter drive
P-08	Section 1 Starts Per Hour	Limits a compressor to this many starts per hour, set to 0 if not required.
P-09	Section 1 Run Smallest	When set to 1 (On), when all compressors are off (because the target pressure has been satisfied) the controller, when the pressure rises, will always turn on the smallest compressor after the variable output has reached 100%. If the ASC timer is running for the smallest compressor, the controller will NOT bring on any other available compressors, the variable output will remain at 100% and the controller will wait until the ASC Timer has elapsed and then turn on the smallest. Please note that this is true for any pressure condition.
P-10	Section 1 Always Run Last	Keeps the last stage running except for a Low Shutdown condition. If the last stage is an inverter, the inverter enable will stay energised, but the inverter analogue output may well decrease to 0% if pressure is below the set-point.
P-11	Section 1 Inverter	Enables the inverter analogue output and associated relay.
P-12	Section 1 Response On Speed	Allows the user to speed up/slow down the stage on speed, 1 being the slowest response and 60 being fastest response.



Please ensure all power is switched off before installing or maintaining this product.

Number	Parameter	Description
P-13	Section 1 Response Off Speed	Allows the user to speed up/slow down the stage off speed, 1 being the slowest response and 60 being fastest response.
P-29	Section 1 Time Constant	For future development, has no effect at present.
P-14	Section 1 Optimise Limit	This is an offset that is added to the target pressure when using the Data Manager Energy feature Pack Optimisation. For example if target pressure is 2.1 Bar and Optimise Limit set to 0.5 Bar. The remote optimise command will only be able to optimise the current suction setpoint up to a maximum of 2.6 Bar.
P-15	Section 1 Discharge Trip Interlock	If set to 1 (On), if the discharge trip is activated, all compressors will switch off.
P-21	Section 1 Night Setback Start Time	The start time at which the night set point (P-04) is utilised.
P-22	Section 1 Night Setback Stop Time	The end time at which the night set point (P-04) is utilised.
P-41	Section 2 Transducer Span*	Range of the transducer.
P-42	Section 2 Transducer Offset*	Transducer value above or below zero.
P-43	Section 2 Day Target	Pressure target, control will try to maintain this pressure during the day, subject to times set on P-61 & P-62
P-44	Section 2 Night Target	Pressure target, control will try to maintain this pressure during the night, subject to times set on P-61 & P-62
P-46	Section 2 Diff Above Target	Set-point above the target, used to obtain a "dead-band" when using an inverter drive
P-47	Section 2 Diff Below Target	Set-point below the target, used to obtain a "dead-band" when using an inverter drive
P-51	Section 2 Inverter	Enables the inverter analogue output and associated relay.
P-52	Section 2 Response On Speed	Allows the user to speed up/slow down the stage on speed, 1 being the slowest response and 60 being fastest response.
P-53	Section 2 Response Off Speed	Allows the user to speed up/slow down the stage off speed, 1 being the slowest response and 60 being fastest response.
P-69	Section 2 Time Constant	For future development, has no effect at present.
P-56	Section 2 Discharge Trip	When the discharge pressure reaches this level all fans switch on. If discharge trip interlock is set to On (P-15), compressors will stage off.
P-57	Section 2 Discharge Stop	When the discharge pressure reaches this level all fans switch on. If discharge trip interlock is set to On (P-15), compressors will switch off straight away. There is a 1 minute delay before coming back on once down to pressure.
P-58	Section 2 Discharge Offset	Diff below for parameters P-56/P-57 at which point control goes back to normal and alarm clears.
P-59	Section 2 Night Setback	Turns on the night set back level. Note This feature is intended to be used when all of the fans are controlled by the inverter. If fan relays are selected, they will never come on as the inverter is required to go to 100% before staging the next fan. There are 4 options : - Off : Night Feature is not used. Controller uses what is set in Day Reduction (P-64) On : Night Reduction (P-60) is always used Local : Uses times in Night Set On and Night Set Off parameters (P61/62) to determine Day / Night



Please ensure all power is switched off before installing or maintaining this product.

Number	Parameter	Description
		Remote : Uses GP Timer to determine Day / Night. GP channel has to be ON, output type=general, output channel =13 for pack/condenser, 11 for condenser only.
P-60	Section 2 Night Reduction	Reduces inverter output by this amount during night settings.
P-61	Section 2 Night Setback Start Time	Time for the night set back feature to operate
P-62	Section 2 Night Setback End Time	Time for the night set back feature to go off
P-63	Section 2 Night Pressure Limit	Pressure set-point to disable the night set back feature. Night set back is disabled above this level and enabled below it.
P-64	Section 2 Day Reduction	Reduces the inverter output by this amount when the timer is not in its night zone.
P-65	Section 2 Day Pressure Limit	Pressure set-point to disable the day reduction feature. Day reduction is disabled above this level and enabled below it.
P-66	Section 2 Control Type	Selects between Fixed or Floating condenser control. Fixed uses the set-point parameter as its target (P-43/44) with the corresponding pressure transducer. Floating uses the temperature of the temperature probe converted to a pressure as the set-point along with the corresponding pressure transducer.
P-67	Condenser Offset	Used to set a condenser differential, which is added to the incoming temperature to produce a "floating" set-point
P-70	Section 2 Refrigerant Type	Selects the gas type look up table for temperature to pressure conversion when using floating head pressure.
P-71	Section 2 Pressure Type	Selects between absolute pressure (0) and gauge pressure (1)
P-72	Section 2 Low Pressure Limit	Stops the floating pressure target from going below this level
P-73	Section 2 High Pressure Limit	Stops the floating pressure target from going above this level
P-82	Section 1 Alarm Delay	Delay before HP and LP alarms are signalled
P-81	Section 1 LP Shutdown Delay	Delay before LP shutdown is activated
P-83	Section 1 HP Alarm	HP alarm set-point
P-84	Section 1 LP Alarm	LP alarm set-point
P-85	S1 LP Shutdown	LP shut-down set-point, all stages go off when this is reached
P-102	Section 2 Alarm Delay	Delay before HP and LP alarms are signalled
P-101	Section 2 LP Shutdown Delay	Delay before LP shutdown is activated
P-103	Section 2 HP Alarm	HP alarm set-point
P-104	Section 2 LP Alarm	LP alarm set-point
P-105	S2 LP Shutdown	LP shut-down set-point, all stages go off when this is reached
P-122	Status Fault Delay	Time delay before status faults are activated
P-123	General Fault Delay	Time delay before general faults are activated
P-131	Stage 1 Input Type ***	0 = Unused: Input is not used 1 = Stage N/O: When selected "Make" to generate a stage fault. 2 = Stage N/C: When selected "Break" to generate a stage fault. 3 = General N/O: When selected "Make" to generate a general fault 4 = General N/C: When selected "Break" to generate a general fault.
P-140	Stage 10 Input Type	



Please ensure all power is switched off before installing or maintaining this product.

Number	Parameter	Description
P-201	Section 1 Stage 1 Output Type	0 = None: Use this option to end the number of stages in the controller 1 = Unused: Use this option to skip a relay output within a stage 2 = Inverter: Use this option to assign a relay to an Inverter 3 = Compressor: Use this option to assign a relay output to a compressor 4 = Loader: Use this option to assign a relay output to a compressor loader 5 = Fan: Use this option to assign a relay to a fan
P-210	Section 1 Stage 10 Output Type	
P-301	Section 2 Stage 1 Output Type	0 = None: Use this option to end the number of stages in the controller 1 = Unused: Use this option to skip a relay output within a stage 2 = Inverter: Use this option to assign a relay to an Inverter 3 = Compressor: Use this option to assign a relay output to a compressor 4 = Loader: Use this option to assign a relay output to a compressor loader 5 = Fan: Use this option to assign a relay to a fan
P-310	Section 2 Stage 10 Output Type	
P-251	Section 1 Stage 1 Compressor Size	Sets the relative size for each compressor.
P-260	Section 1 Stage 10 Compressor Size	
DFLT	Restore Default Settings	Sets all parameters back to factory settings.
Esc		

Refrigerant Table

No.	Gas	No.	Gas	No.	Gas	No.	Gas	No.	Gas
0	None	6	R32	12	R401A	18	R407A	24	R507
1	R12	7	R114	13	R401B	19	R407B	25	R717
2	R13	8	R134A	14	R402	20	R407C	26	R290
3	R13B1	9	R142B	15	R402A	21	R500	27	R744
4	R22	10	R227	16	R402B	22	R502	28	R407F
5	R23	11	R401	17	R404A	23	R503	29	R410A



Please ensure all power is switched off before installing or maintaining this product.

Configuration of inputs and outputs

Stage Inputs

Status inputs can be configured as Normally Open or Normally Closed and can be set as Stage Fault, General Fault or Unused.

Section Stages

Section stages can be set up as; None, Unused, Inverter, Compressor, Loader or Fan. These parameters determine which relay is assigned to the section outputs.

There are a total of 10 relays that can be assigned in any combination.

Stage	Description	Comments
None	Use this option to end the number of stages in the controller If the controller is a 2 section type (Type 2 or 3) this will indicate the end of the 1 st section and start assigning subsequent relays to the 2 nd stage	
Unused	Use this option to skip a relay output within a stage	
Inverter	Use this option to assign a relay output to an inverter enable signal.	
Comp	Use this option to assign a relay output to a compressor	See note 4 below
Loader	Use this option to assign a relay output to a compressor loader	
Fan	Use this option to assign a relay to a fan	

Note 4: In a pack configuration, at least 1 output must be assigned to a compressor. Loader outputs will not energise without a compressor being on.

Example: Pack/Condenser mode (Type3)

The screenshot shows the 'Parameters' configuration screen with the following settings:

Section 1 Stage Types	Section 2 Stage Types
Sect 1 Stg 1: Comp	Sect 2 Stg 1: Fan
Sect 1 Stg 2: Loader	Sect 2 Stg 2: Fan
Sect 1 Stg 3: Comp	Sect 2 Stg 3: Fan
Sect 1 Stg 4: Loader	Sect 2 Stg 4: None
Sect 1 Stg 5: Comp	Sect 2 Stg 5: None
Sect 1 Stg 6: Loader	Sect 2 Stg 6: None
Sect 1 Stg 7: None	Sect 2 Stg 7: None
Sect 1 Stg 8: None	Sect 2 Stg 8: None
Sect 1 Stg 9: None	Sect 2 Stg 9: None
Sect 1 Stg 10: None	Sect 2 Stg 10: None

Relay assignments shown in the diagram:

- Relay 1 → Sect 1 Stg 1 (Comp)
- Relay 2 → Sect 1 Stg 2 (Loader)
- Relay 3 → Sect 1 Stg 3 (Comp)
- Relay 4 → Sect 1 Stg 4 (Loader)
- Relay 5 → Sect 1 Stg 5 (Comp)
- Relay 6 → Sect 1 Stg 6 (Loader)
- Relay 7 → Sect 2 Stg 1 (Fan)
- Relay 8 → Sect 2 Stg 2 (Fan)
- Relay 9 → Sect 2 Stg 3 (Fan)
- Relay 10 not used

This configuration shows a 6-stage pack with a 3-stage condenser controller.

All status inputs are assigned to N/O, making the first 6 inputs are section 1 stage 1-6 (compressor and loaders), the next 3 inputs are section 2 stage 1-3 (fans).



Please ensure all power is switched off before installing or maintaining this product.

Stage Sizes

Stage sizes will determine the order in which compressors or loaders are switched on and off. This is a relative number between 0 and 60, reflecting the size of the compressor (usually horse power)

The default stage size is 0; stage sizes must be entered for correct operation.

Operation

Once the controller has been set-up and configured, normal operation will resume. The controller operates a "fuzzy logic" based control algorithm. The controller will determine the stages to bring on and off using the fuzzy logic rules and adhering to the starts/hr criteria. Note that on and off delays will vary according to the current conditions. The fuzzy logic will attempt to optimise the compressor starts and keep them at a minimum.

Run Times

The controller monitors and holds information on how long each compressor/ fan is running for. It can be viewed within the controller's web page under 'Run Times'. To clear these figures go through 'Configure', by logging in and then 'Clear Run Times'.

Viewing Inputs and Outputs

Apart from setting up the controller, you can also view the status of the inputs and outputs.

1. From the function menu, select "IO", press enter
2. You can now scroll through the IO tables as set out below. The tables you view will depend on the controller type configuration.

Input/ Output Tables

Input/ Output table for Pack Controller (Type 1)

Number	IO	Range	Units
I-01	Suction Pressure	-3.4 – 50	Bar
I-11	Status Input 1	(0) OK (1) Alarm (2) Unused	
↓	↓		
I-20	Status Input 10		
I-31	Temperature Probe	-49 - +158	°C
0-01	Relay 1	(0) Off (1) On	
↓	↓		
0-10	Relay 10		
0-31	Variable Output	0 – 100	%
0-41	Optimisation Level	-3.4 – 50	Bar
S-01	Section 1 Control States	(0) Off (1) Stabilize (2) Initial (3) Normal (4) High Pressure (5) Low Pressure (6) Low Shut-down (7) Transducer Fail (8) Stand-by (9) Trip (10) Stop	



Please ensure all power is switched off before installing or maintaining this product.

Input/ Output table for Dual Pack Controller (Type 2)

Number	IO	Range	Units
I-01	Section 1 Suction Pressure	-3.4 – 50	Bar
I-02	Section 2 Suction Pressure	-3.4 – 50	Bar
I-11 ↓ I-20	Status Input1 ↓ Status Input 10	(0) OK (1) Alarm (2) Unused	
I-31	Temperature Probe	-49 - +158	°C
0-01 ↓ 0-10	Relay 1 ↓ Relay 10	(0) Off (1) On	
0-31	Section 1 Variable Output	0-100	%
0-32	Section 2 Variable Output	0-100	%
0-41	Section 1 Optimisation Level	-3.4 – 50	Bar
0-42	Section 2 Optimisation Level	-3.4 – 50	Bar
S-01	Section 1 Control States	(0) Off (1) Stabilize (2) Initial (3) Normal (4) High Pressure (5) Low Pressure (6) Low Shut-down (7) Transducer Fail (8) Stand-by (9) Trip (10) Stop	
S-02	Section 2 Control States	(0) Off (1) Stabilize (2) Initial (3) Normal (4) High Pressure (5) Low Pressure (6) Low Shut-down (7) Transducer Fail (8) Stand-by (9) Trip (10) Stop	



Please ensure all power is switched off before installing or maintaining this product.

Input/ Output table for Pack/Condenser Controller (Type 3)

Number	IO	Range	Units
I-01	Section 1 Suction Pressure	-3.4 – 50	Bar
I-02	Section 2 Suction Pressure	-3.4 – 50	Bar
I-11 ↓ I-20	Status Input1 ↓ Status Input 10	(0) OK (1) Alarm (2) Unused	
I-31	Temperature Probe	-49 - +158	°C
I-41	Floating Pressure	-3.4 – 50	Bar
0-01 ↓ 0-10	Relay 1 ↓ Relay 10	(0) Off (1) On	
0-31	Section 1 Variable Output	0-100	%
0-32	Section 2 Variable Output	0-100	%
0-41	Section 1 Optimisation Level	-3.4 – 50	Bar
0-62	Section 2 Night Setback	(0) Off (1) On	
S-01	Section 1 Control States	(0) Off (1) Stabilize (2) Initial (3) Normal (4) High Pressure (5) Low Pressure (6) Low Shut-down (7) Transducer Fail (8) Stand-by (9) Trip (10) Stop	
S-02	Section 2 Control States	(0) Off (1) Stabilize (2) Initial (3) Normal (4) High Pressure (5) Low Pressure (6) Low Shut-down (7) Transducer Fail (8) Stand-by (9) Trip (10) Stop	



Please ensure all power is switched off before installing or maintaining this product.

Input/ Output table for Condenser Controller (Type 4)

Number	IO	Range	Units
I-01	Discharge Pressure	-50 – 500	Bar
I-11	Status Input 1	(0) OK (1) Alarm (2) Unused	
↓	↓		
I-20	Status Input 10		
1-31	Temperature Probe	-50 - +70	°C
I-41	Floating Pressure	-3.4 – 50	Bar
0-01	Relay 1	(0) Off (1) On	
↓	↓		
0-10	Relay 10		
0-31	Section 1 Variable Output	0-100	%
0-61	Section 1 Night Setback	(0) Off (1) On	
S-01	Section 1 Control States	(0) Off (1) Stabilize (2) Initial (3) Normal (4) High Pressure (5) Low Pressure (6) Low Shut-down (7) Transducer Fail (8) Stand-by (9) Trip (10) Stop	

Override

The override function allows the user to switch output stages on or off. (Providing the output stages have been configured)

Press the override and enter button together for approx. 3 secs.

Use the “up” button to turn the stage on, and the down button to turn the stage off.

Press “enter” to exit this mode or allow the time-out to elapse.

Standby Mode

The controller requires a 590 Ohm resistor present across Probe input 11 and common (gnd) for normal operation. If the resistor is not detected; such as in a fault condition, the controller will go into standby mode. All compressors and/or fans will be turned off and an alarm (controller in standby) generated.

There is a 10 second delay for the detection of the resistor, both in and out.

Display Messages

The following messages can appear on the Mercury display during normal operation.

Display	System status	Display	System Status
Hp	High Pressure alarm	Stby	Controller in standby
LP	Low Pressure alarm	triP	Discharge Trip
trAn	Pressure Transducer alarm	Sd	Low pressure Shutdown
Ft	Fault	Boot	Configuration error or restart



Please ensure all power is switched off before installing or maintaining this product.

Network Alarms

The table below shows the text and associated type number that is sent to the system “front end”. The type number is normally used to provide different alarm actions.

Alarm text	Type #
Section 1 Pack High Pressure	8
Section 1 Pack Low Pressure	9
Section 1 Pack Low Shutdown	10
Section 1 Pack Pressure Probe Fault	6
Section 2 Pack High Pressure	8
Section 2 Pack Low Pressure	9
Section 2 Pack Low Shutdown	10
Section 2 Pack Pressure Probe Fault	6
Section 1 Cond High Pressure	12
Section 1 Cond Low Pressure	11
Section 1 Cond Low Shutdown	11
Section 1 Cond Pressure Probe Fault	6
Section 2 Cond High Pressure	12
Section 2 Cond Low Pressure	11
Section 2 Cond Low Shutdown	11
Section 2 Cond Pressure Probe Fault	6
General Fault 1	20
General Fault 2	20
General Fault 3	20
General Fault 4	20
General Fault 5	20
General Fault 6	20
General Fault 7	20
General Fault 8	20
General Fault 9	20
General Fault 10	20
Section 1 Stage 1	3
Section 1 Stage 2	3
Section 1 Stage 3	3
Section 1 Stage 4	3
Section 1 Stage 5	3
Section 1 Stage 6	3
Section 1 Stage 7	3
Section 1 Stage 8	3
Section 1 Stage 9	3
Section 1 Stage 10	3
Section 2 Stage 1	3
Section 2 Stage 2	3
Section 2 Stage 3	3
Section 2 Stage 4	3
Section 2 Stage 5	3
Section 2 Stage 6	3
Section 2 Stage 7	3
Section 2 Stage 8	3
Section 2 Stage 9	3
Section 2 Stage 10	3
Configuration fault	20
Controller in standby	20



Please ensure all power is switched off before installing or maintaining this product.

Specification

Power requirements for PR0332 and PR0334:

Supply Voltage Range:	100 – 240 Vac $\pm 10\%$
Supply Frequency:	50 – 60 Hz $\pm 10\%$
Maximum supply current:	<1 Amp (with no relay loads) 10 Amps (with relays 4, 5, 9 and 10 fully loaded)
Typical supply current:	<1.0 Amp
Class 2 Insulation:	No protective Earth is required and none should be fitted.

The host equipment must provide a suitable external over-current protection device such as: -
 Fuse: 10A, 240 Vac Antisurge (T) HRC conforming to IEC 60127
 Or MCB: 10A, 240 Vac Type C conforming to BS EN 60898

The host equipment must provide adequate protection against contact to hazardous live parts.

Power requirements for PR0333 and PR0335:

Supply Voltage Range:	10 Vdc to 35 Vdc or 15 Vac to 30 Vac
AC Supply Frequency:	50 – 60 Hz $\pm 10\%$
Maximum supply current:	1 Amp (Controller only)
Typical supply current:	<1.0 Amp (Controller only)
Class 2 Insulation:	The supply ground can be earthed if required.

The host equipment must provide a suitable external over-current protection device such as: -
 Fuse: 3A, 240 Vac Antisurge (T) HRC conforming to IEC 60127
 Or MCB: 3A, 240 Vac Type C conforming to BS EN 60898

The host equipment must provide adequate protection against contact to hazardous live parts.

General

Operating temperature range:	-10°C to +60°C
Operating Humidity:	80% maximum
Storage temperature range:	-20°C to +65°C
Environmental:	Indoor use at altitudes up to 2000m, Pollution Degree 1, Installation Category II. Voltage fluctuations not to exceed $\pm 10\%$ of nominal voltage
Size:	180mm (W) x 68mm (H) x 110mm (D)
Weight:	260 Grams
Safety:	EN61010
EMC:	EN61326; 1997 +Amdt. A1; 1998
Ventilation:	There is no requirement for forced cooling ventilation

Inputs

Probe Input type	PT1000 for all versions
Status Input type	0 volt return (internal pull-up resistor give high state when there is no return)
Comms:	RS232 with flow control
4-20Ma	4-20Ma current loop, use the 12 Vdc output to feed the pressure transducer

Analogue Outputs

0 to 10 Volts DC or 0/4-20Ma, selected in the front panel menu and jumper position.
 A 50Ma fuse is recommended for each Analogue output.

The 4-20Ma output will not operate correctly if the target device input impedance is $> 75\Omega$

The 0-10V output will not operate correctly if the target device input impedance is $< 10K\Omega$



Please ensure all power is switched off before installing or maintaining this product.

Relay Ratings for PR0332 and PR0334

Max current relay 1:	6A (non inductive)	
Max Voltage relay 1:	260Vac (external supply)	Exclusive common
Max current relay 2:	4A (non inductive)	
Max Voltage relay 2:	260Vac (external supply)	Relays 2 and 3 share a common supply line and the loads can have a combined total of 8A.
Shared common with relay 3		
Max current relay 3:	4A (non inductive)	
Max Voltage relay 3:	260Vac (external supply)	Relay 2 or 3 can switch a maximum of 6A provided the other is at 2A or lower.
Shared common with relay 2		
Max current relay 4:	3A (non inductive)	
Max Voltage relay 4:	260Vac (Internal supply)	
Common connected to supply 1 "live"		
Max current relay 5:	3A (non inductive)	
Max Voltage relay 5:	260Vac (Internal supply)	
Common connected to supply 1 "live"		
Max current relay 6:	6A (non inductive)	
Max Voltage relay 6:	260Vac (external supply)	Exclusive common
Max current relay 7:	4A (non inductive)	
Max Voltage relay 7:	260Vac (external supply)	Relays 7 and 8 share a common supply line and the loads can have a combined total of 8A.
Shared common with relay 8		
Max current relay 8:	4A (non inductive)	
Max Voltage relay 8:	260Vac (external supply)	Relay 7 or 8 can switch a maximum of 6A provided the other is at 2A or lower.
Shared common with relay 2		
Max current relay 9:	3A (non inductive)	
Max Voltage relay 9:	260Vac (Internal supply)	
Common connected to supply 2 "live"		
Max current relay 10:	3A (non inductive)	
Max Voltage relay 10:	260Vac (Internal supply)	
Common connected to supply 2 "live"		



Please ensure all power is switched off before installing or maintaining this product.

Relay Ratings for PR0333 and PR0335

Max current relay 1:	6A (non inductive)	Exclusive common
Max Voltage relay 1:	24Vac (external supply)	
Max current relay 2:	4A (non inductive)	Relays 2 and 3 share a common supply line and the loads can have a combined total of 8A.
Max Voltage relay 2:	24Vac (external supply)	
Shared common with relay 3		
Max current relay 3:	4A (non inductive)	Relay 2 or 3 can switch a maximum of 6A provided the other is at 2A or lower.
Max Voltage relay 3:	24Vac (external supply)	
Shared common with relay 2		
Max current relay 4:	3A (non inductive)	Relays 4 and 5 share a common supply line and the loads can have a combined load of 6A
Max Voltage relay 4:	24Vac (external supply)	
Max current relay 5:	3A (non inductive)	
Max Voltage relay 5:	24Vac (external supply)	
Max current relay 6:	6A (non inductive)	Exclusive common
Max Voltage relay 6:	24Vac (external supply)	
Max current relay 7:	4A (non inductive)	Relays 7 and 8 share a common supply line and the loads can have a combined total of 8A.
Max Voltage relay 7:	24Vac (external supply)	
Shared common with relay 8		
Max current relay 8:	4A (non inductive)	Relay 7 or 8 can switch a maximum of 6A provided the other is at 2A or lower.
Max Voltage relay 8:	24Vac (external supply)	
Shared common with relay 7		
Max current relay 9:	3A (non inductive)	Relays 9 and 10 share a common supply line and the loads can have a combined total of 6A.
Max Voltage relay 9:	24Vac (external supply)	
Max current relay 10:	3A (non inductive)	
Max Voltage relay 10:	24Vac (external supply)	

Important Safety Notice:

PR0332 and PR0334 must use a voltage level the same as the supply input voltage on all of the relays common.

PR0333 and PR0335 must use a voltage level no greater than 40Vdc or 30 Vac on all of the relays common.



Please ensure all power is switched off before installing or maintaining this product.

Installation:

Panel Cut-out:

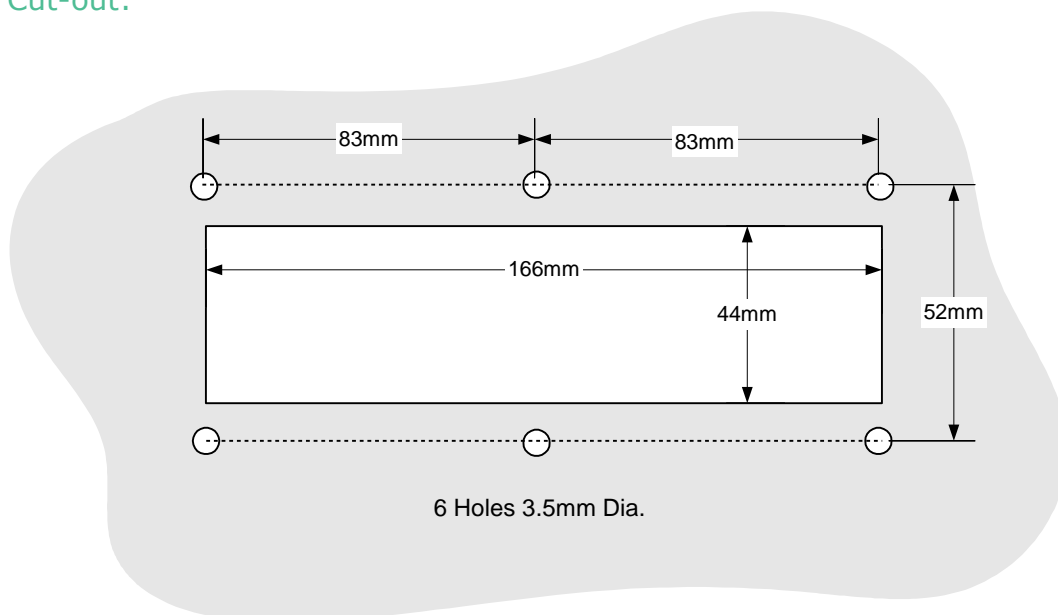

Fixing:

6 X M3 screws from the rear fix the controller.

DIN rail: Use PR0039 to mount the controller to a DIN rail.

Clearances:

The controller must have 5mm clearance above the top and below bottom, and 25mm clearance from the sides. Clearance at the rear is dependent on the wiring. There is no requirement for forced cooling ventilation



Please ensure all power is switched off before installing or maintaining this product.

Wiring for PR0332 & PR0334:

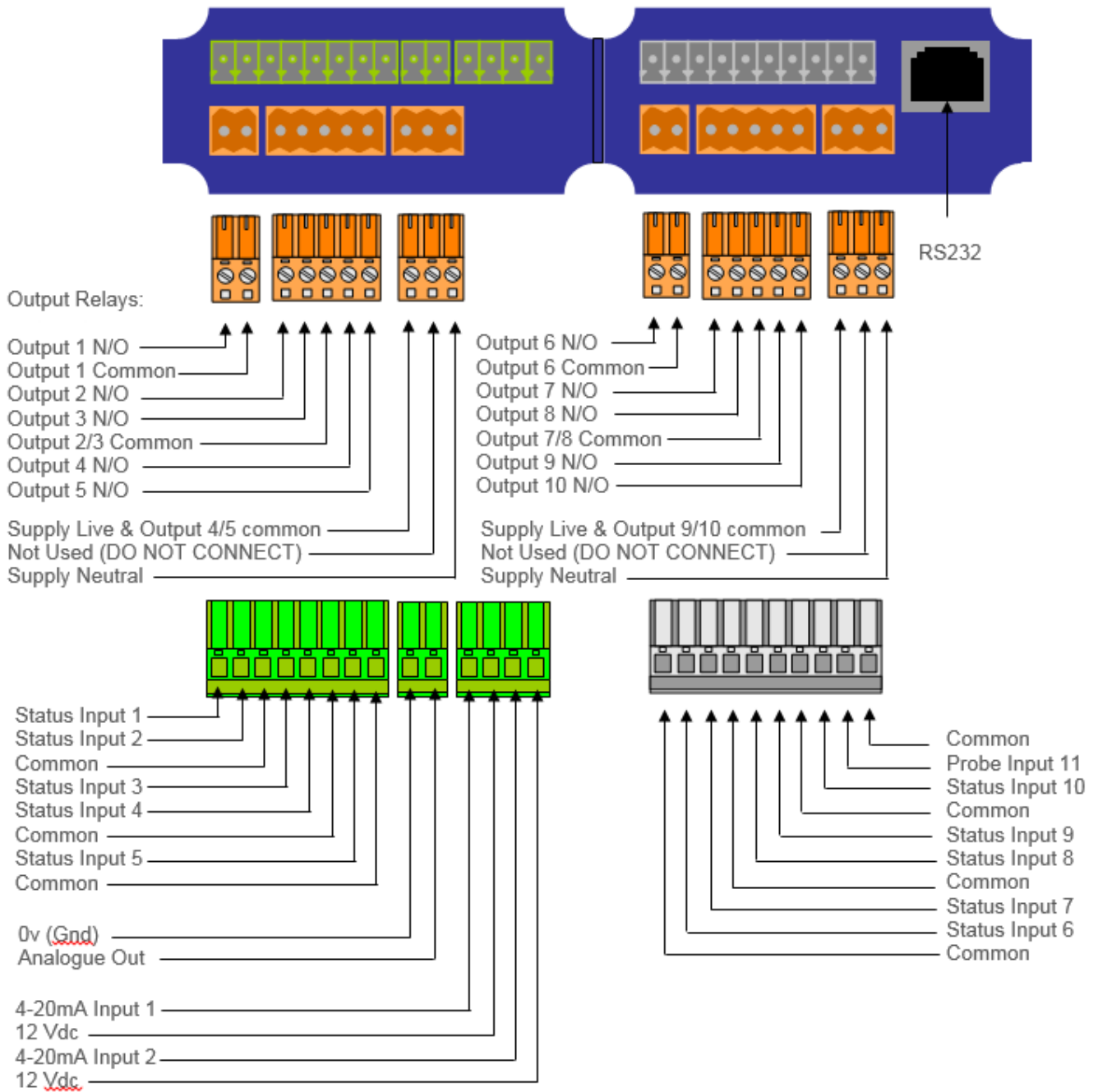

Note:

Suitable mechanical restraints on the wiring to the controller may be required; dependant on cable types, to prevent undue stress or distortion on the controller connectors.



Please ensure all power is switched off before installing or maintaining this product.

Wiring for PR0333 & PR0335:

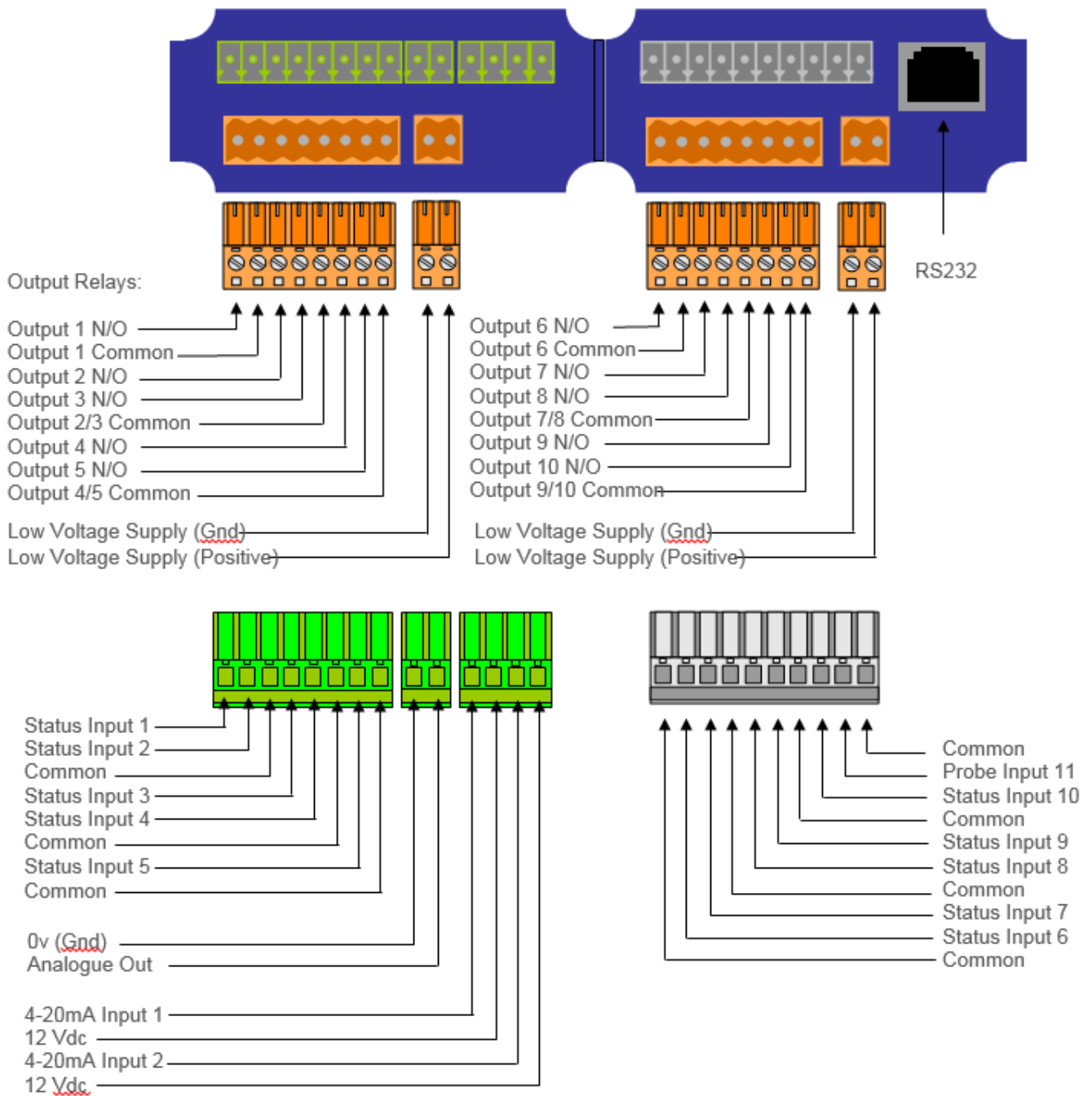

Note:

Suitable mechanical restraints on the wiring to the controller may be required; dependant on cable types, to prevent undue stress or distortion on the controller connectors.

Cleaning:

Do not wet the controller when cleaning. Clean the front by wiping with a slightly dampened lint free cloth.



Please ensure all power is switched off before installing or maintaining this product.

Appendix 1

Typical Transducer Connection

For 4-20mA type transducers the diagram below shows the connections to the Mercury 11-10PV: -

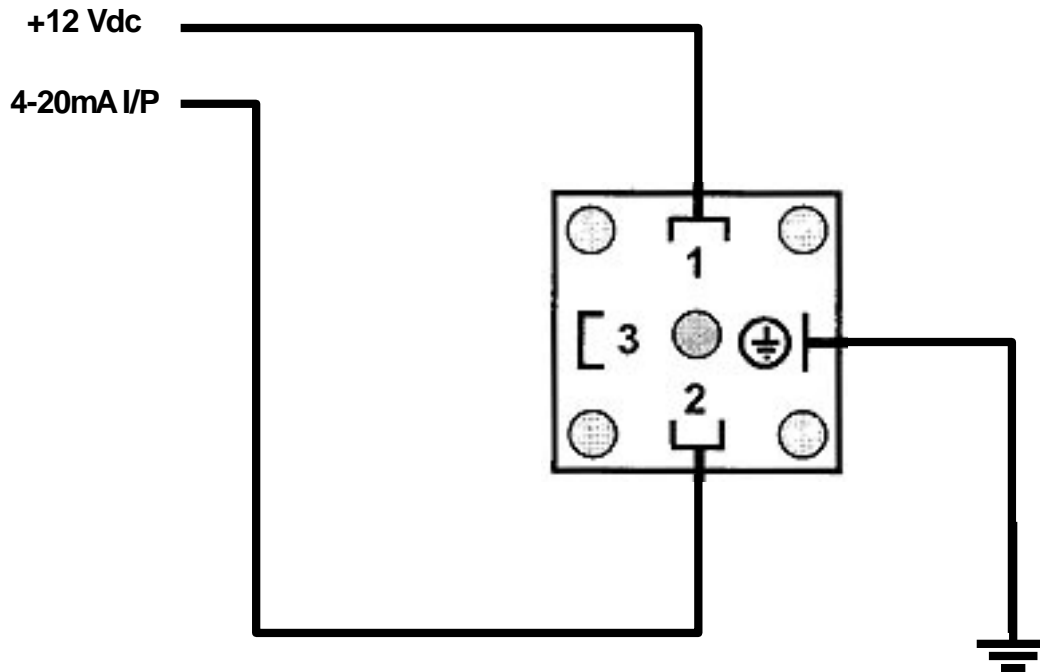

Note: The Earth connection is not necessary unless in a noisy environment.

Revision History

Revision	Date	Changes
6.0	19/07/2013	First release of ARM processor variant.
6.1	25/07/2013	Spelling corrections.
6.5	05/11/2013	Run Hours clear function added within controller web pages
6.6	07/11/2014	Description of temperature probe updated, can now be used for floating head pressure control.
6.6a	06/01/2015	Operating temperature range updated.
6.6b	20/01/2015	Address update.
6.7	27/01/2016	All references to Digital Input standardised to Status input.
6.7a	10/01/2018	New documentation format.
6.7b	27/11/2019	P-58 Description updated.
6.7c	09/01/2020	Layout tidied up.



Please ensure all power is switched off before installing or maintaining this product.

Group Offices

RDM Group Head Office

80 Johnstone Avenue
Hillington Industrial Estate
Glasgow
G52 4NZ
United Kingdom

+44 (0)141 810 2828
support@resourcedm.com

RDM Inc

100 North Sixth Street
Suite 630B
Minneapolis, MN
55403
United States

+1 612 354 3923
usasupport@resourcedm.com

RDM Asia

Sky Park at One City
Jalan USJ 25/1
47650 Subang Jaya
Selangor
Malaysia

+60 3 5022 3188
info@rdmasia.com.my



Visit www.resourcedm.com/support for more information on RDM solutions, additional product documentation and software downloads.

While every effort is made to ensure the information given within this document is accurate, Resource Data Management Ltd shall not be liable for errors or omissions, for incidental or consequential damages, directly or indirectly, in connection with the furnishing, performance or misuse of this product or document. All specifications are subject to change without notice.

See www.resourcedm.com for terms and conditions of sales.

Copyright © Resource Data Management