

Resource
Data Management

USB 4G Modem

Installation/User Guide

Revision 1.0



PR0496-4G

Contents

USB 4G Modem.....	3
Specification	3
4G Modem for DMTouch	4
Installation Instructions - DMTouch	4
Setup Instructions - DMTouch	6
Revision History	7



Please ensure all power is switched off before installing or maintaining this product.

USB 4G Modem

The USB 4G modem can be used with the DMTouch. When used in conjunction with the DMTouch it allows alarms generated to be sent via SMS to a designated mobile telephone number.



Features

- Internal antenna
- No Power Supply Required
- Low Cost
- Easy Installation

Note 1: The unit is only compatible with DMTouch V2 hardware running version 4.2 or above. Please note that this will only work when using a standard size sim card that is enabled to send SMS. **It must be used in conjunction with the supplied dual USB adapter.**

Specification

Box Contents

- 1 x USB 4G Modem
- 1 x Dual USB port cable

Hardware Features	
Standards and Protocols	LTE / DC-HSPA+ / HSPA+ / HSPA / UMTS / EDGE / GPRS / GSM
Interface	USB 2.0
LED Indicator	Three-colour LED providing status information (see table below)
Dimensions (HxWxD)	94mm x 30mm x 14mm (3.7 x 1.18 x 0.55in)
Weight	40g
Antenna Type	External Antenna: TS-5
GSM Band	850/900/1800/1900MHz
Others	
Certifications	CE, FCC, RoHS
Environment	Operating Temperature: -10°C to +40°C (+14°F to +104°F) Storage Temperature: -20°C to +70°C (-4°F to +158°F)



Please ensure all power is switched off before installing or maintaining this product.

4G Modem for DMTouch

Installation Instructions - DMTouch

1. Contact RDM Technical support as DM may require drivers installed.
2. Turn off the DMTouch and isolate the power.
3. Remove the right hand side wing by unscrewing the 2 screws at the top and bottom of each wing.
4. Locate the USB ports at the bottom of the panel.
5. Ensure the SIM is enabled to send SMS messages. Contact the SIM provider to confirm if necessary.
6. Remove the modem from its packaging and remove the front of the adapter by sliding it forward. Insert the SIM card (Can be PAYG or Contract sim enabled to send SMS) as shown in the illustration below.

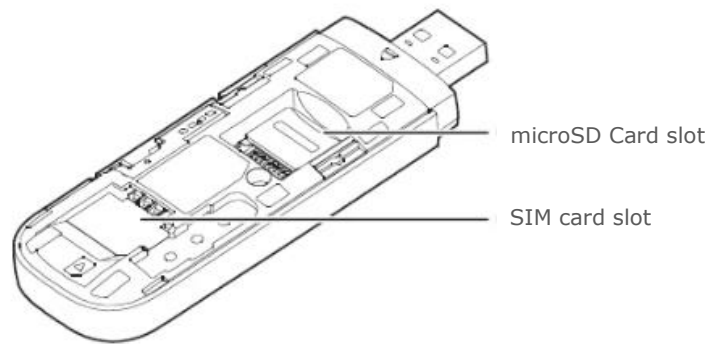

7. Remove the top of the USB modem to reveal the USB plug.



8. Now fit the dual USB adapter into two free USB ports on the DMTouch. **Note:** If there are not two USB ports available, then a PR0624 DIN (USB 4 port hub) must be used to connect the 4G modem to the DMTouch. Now connect the USB modem to the free end of the USB cable.



Please ensure all power is switched off before installing or maintaining this product.

9. Next, replace the DMTouch side cover and secure it with the screws.
10. The unit connects to a mobile network to gain access to an Internet connection. For this reason the unit has to be placed in an area of the building which has access to the requisite mobile telephone network (e.g. Vodafone, O2, EE, Three, etc.).
11. The 4G modem hardware installation is now complete.

LED Indicator	
Green, blinking twice every 2s	The USB Stick is powered on
Green, blinking once every 0.2s	The software of the USB-Modem is being upgraded
Blue, blinking once every 2s	The USB Stick is registering with a 4G network
Blue, solid	The USB Stick is connected to a 4G network
Cyan, blinking once every 2s	The USB Stick is registering with an LTE network
Cyan, solid	The USB Stick is connected to a 4G+/LTE network
Off	The USB Stick is removed



Please ensure all power is switched off before installing or maintaining this product.

Setup Instructions - DMTouch

Note: For the purpose of testing and demonstration, this guide uses a Vodafone SIM card and the Vodafone network settings. Please contact your mobile network provider for their particular settings.

Within the menu of the DMTouch, navigate to 'Service' – 'System' – 'Miscellaneous' – '4G Dongle Setup'. To successfully send SMS text messages, the service centre address details must be entered. The information below is provided by Vodafone and as a result may change at any time. For any queries please contact the relevant service provider.

Carrier	Service Centre Address
Vodafone	+447785016005
EE	+447958879879
O2	+447802092035
Three (3)	+447782000800

**Above numbers are correct as of September 2022*

For alarms to be sent, the destination / recipient must be entered within the 'Modem Setup' menus. Found under 'Service' – 'Alarms' – 'Modem Setup'. This can be any mobile telephone number, however the type must be set to 'SMS (GSM Modem)'.

To confirm successful setup, generate an alarm on the DMTouch and confirm a SMS text message gets sent to the desired destination. Please consult the DMTouch Installation Guide for help in configuring the alarm actions and modem destinations



Please ensure all power is switched off before installing or maintaining this product.

Revision History

Date	Version	Update No	Changes
05/09/2022	V1.0	01	First release



Please ensure all power is switched off before installing or maintaining this product.

Group Offices

RDM Group Head Office

80 Johnstone Avenue
Hillington Industrial Estate
Glasgow
G52 4NZ
United Kingdom

+44 (0)141 810 2828
support@resourcedm.com

RDM USA

9441 Science Center Drive
New Hope
Minneapolis
MN 55403
United States

+1 612 354 3923
usasupport@resourcedm.com

RDM Asia

Sky Park at One City
Jalan USJ 25/1
47650 Subang Jaya
Selangor
Malaysia

+60 3 5033 0599/0588
asiatech@resourcedm.com



Visit www.resourcedm.com/support for more information on RDM solutions, additional product documentation and software downloads.

While every effort is made to ensure the information given within this document is accurate, Resource Data Management Ltd shall not be liable for errors or omissions, for incidental or consequential damages, directly or indirectly, in connection with the furnishing, performance or misuse of this product or document. All specifications are subject to change without notice.

See www.resourcedm.com for terms and conditions of sales.

Copyright © Resource Data Management