

Resource
Data Management

Energy Meter

Commissioning/User Guide

Revision 1.4b



PR0670-3PH

Contents

Introduction	4
Unit Characteristics.....	4
Current Transformer Primary Current.....	4
Pulse Output	5
Start Up Screens	5
Measurements.....	5
Voltage and current measurement	6
Frequency, power factor and demand.....	7
Power	8
Energy Measurements	9
Setting Up	10
Menu Option Selection.....	11
Number Entry Procedure	11
Changing the password	12
DIT Demand Integration Time	13
Current Transformer (CT) Range	14
Voltage Transformer (PT) Range.....	14
Pulse output.....	15
Pulse rate	15
Pulse Duration.....	16
Communication	17
Modbus Address	17
Baud Rate.....	17
Parity	18
Stop bits.....	19
CLR.....	19
Specifications.....	20
Measured Parameters.....	20
Voltage and Current.....	20
Power factor, Frequency and Maximum Demand.....	20
Energy Measurements.....	20
Measured Inputs.....	20
Accuracy	20
Auxiliary Supply	21
Interfaces for External Monitoring.....	21
Pulse Output	21



Please ensure all power is switched off before installing or maintaining this product.

RS485 Output for Modbus RTU 21

Reference Conditions of Influence Quantities 21

Environment 22

Mechanical 22

Installation 23

 RS485 wiring 23

 Modbus Registers 24

Revision History 26



Please ensure all power is switched off before installing or maintaining this product.

Introduction

This document provides operating, maintenance and installation instructions. The unit measures and displays the characteristics of three phase, four wires (3p4w) supplies, including voltage, frequency, current, power, active and reactive energy, imported or exported. Energy is measured in terms of kWh and kVAh. Maximum demand current can be measured over preset periods of up to 60 minutes. In order to measure energy, the unit requires voltage and current inputs in addition to the supply required to power the product. The requisite current input(s) are obtained via current transformers (CT).

This meter can be configured to work with a wide range of CTs with a secondary 0.33V output, giving the unit a wide range of operation. Built-in interfaces provide pulse and RS485 Modbus outputs. Configuration is password protected.

The unit can be powered from a separate auxiliary (AC or DC) supply or alternatively it can be powered from the monitored supply where appropriate.

Unit Characteristics

The meter can measure and display:

- Line voltage and THD% (total harmonic distortion) of all phases
- Line Frequency
- Current, Current demands and current THD% of all phases
- Power, maximum power, demand and power factor
- Active energy imported and exported
- Reactive energy imported and exported

The meter has password-protected set-up screens for:

- Changing password
- Demand interval time
- Reset for demand measurements
- Pulse output duration

Two pulse output indicates real-time energy measurement. An RS485 output allows connection to an RDM Data Manager or TDB Plant controller using a suitable Modbus interface

Current Transformer Primary Current

The meter can be configured to operate using CTs with a fixed 0.33V output, the primary ratio is optional depending on range to be measured.

NOTE: The primary current transformer ratio is defaulted to 5A and requires setting to match the size of the current transformers being used (400A for example). See: [Current Transformer \(CT\) Range](#)



Please ensure all power is switched off before installing or maintaining this product.

Pulse Output

This provides two pulse outputs that are activated after a measured amount of active and reactive energy has been consumed. The pulse width for active energy can be set from the set-up menu.

Start Up Screens



The first screen lights up all display segments and can be used as a display check.



These display symbols are not used in this application and will only appear on display check power up.



The second screen indicates the firmware installed in the unit and its build number.



The interface performs a self-test and shows the result.

After a short delay, the screen will display active energy measurements.

Measurements

The menu buttons operate as follows:



Selects the Voltage and Current display screens. In Set-up Mode, this is the "Left" or "Back" button.



Select the Frequency and Power factor display screens. In Set-up Mode, this is the "Up" button.



Please ensure all power is switched off before installing or maintaining this product.



Select the Power display screens.
In Set-up Mode, this is the "Down" button.



Select the Energy display screens.
In Set-up mode, this is the "Enter" or "Right" button.

Voltage and current measurement

Each successive pressing of the  button selects a new range:



Phase to neutral voltages



Current on each phase



Phase to neutral voltage THD%



Current THD% for each phase



Please ensure all power is
switched off before installing
or maintaining this product.

Frequency, power factor and demand

Each successive pressing of the  button selects a new range:



Frequency and Power Factor (total)



Power Factor of each phase



Maximum Power Demand



Maximum Current Demand



Please ensure all power is switched off before installing or maintaining this product.

Power

Each successive pressing of the  button select a new range:



Instantaneous Active Power in kW



Instantaneous Reactive Power in kVAr



Instantaneous Volt-amps in KVA



Total kW, kVArh, kVA



Please ensure all power is switched off before installing or maintaining this product.

Energy Measurements

Each successive pressing of the  button selects a new range:



Imported active energy in kWh



Exported active energy in kWh



Imported reactive energy in kVAh



Exported reactive energy in kVAh



Total active energy in kWh



Please ensure all power is switched off before installing or maintaining this product.



Total reactive energy in kVAh

Setting Up

To enter set-up mode, pressing the



button for 3 seconds, until the password screen appears.



The setup menus are protected so you must enter the correct password (default '1000') before proceeding. If an incorrect password is entered, the display will show: PASSErr



To exit setting-up mode, press













repeatedly until the measurement screen is restored.







Please ensure all power is switched off before installing or maintaining this product.

Menu Option Selection

- 1) Use the  and  buttons to select the required item from the menu. Selection does not roll over between bottom and top of list.
- 2) Press  to confirm your selection.
- 3) If an item flashes, then it can be adjusted by the  and  buttons. If the value does not flash then there will be a further sub menu.
- 4) Having selected an option from the current menu, press and hold  for 3 seconds to confirm your selection. The SET indicator will appear.
- 5) Having completed a parameter setting, press  to return to a higher menu level. The SET indicator will be removed and you will be able to use the  and  buttons for further menu selection.
- 6) On completion of all setting-up, press  repeatedly until the measurement screen is restored.

Number Entry Procedure

When setting up the meter, some screens require the entering of a number, for instance when accessing the setup section, a password must be entered. Digits are entered individually, from left to right. The procedure is as follows:

- 1) The current digit to be set flashes and is set using the  and  buttons.
- 2) Press  to confirm each digit setting. The SET indicator appears after the last digit has been set.
- 3) After setting the last digit, press  to exit the number setting routine. The SET indicator will be removed.



Please ensure all power is switched off before installing or maintaining this product.

Changing the password



Use **M ▲** and **P ▼** to select the change password option.



Press **E ▶** to enter the change password routine. The new password screen will appear with the first digit flashing.



Use **M ▲** and **P ▼** to set the first digit.

Press **E ▶** to confirm the selection. The next digit will flash.



Repeat the procedure for the remaining three digits.



After setting the last digit, SET will show.

Press **U/I ◀** to exit the number setting routine and return to the Set-up menu.



Please ensure all power is switched off before installing or maintaining this product.

DIT Demand Integration Time

This sets the period in minutes over which the current and power readings are measured for maximum demand measurement. The options are: Off, 5, 10, 15, 30 and 60 minutes.



From the set-up menu, use **M ▲** and **P ▼** buttons to select the DIT option.

The screen will show the currently selected integration time.



Press **E ▶** to enter the selection routine.
The current time interval will flash



Use **M ▲** and **P ▼** buttons to select the time period required (in minutes).



Press **E ▶** to confirm the selection.
SET indicator will appear.

Press **U/I ESC** to exit the DIT selection routine and return to the menu.



Please ensure all power is switched off before installing or maintaining this product.

Current Transformer (CT) Range

The CT option selects the primary current range of the current transformer, (the secondary is fixed at 0.333V (AC) output).



From the Set-up menu, use the **M ▲** and **P ▼** buttons to select the CT primary (CT1) size.

Default is 5A, and range is 0005 to 9999.



Secondary CT (CT2) is fixed at 0.333V on this meter and cannot be changed.

Voltage Transformer (PT) Range

The PT option sets the secondary voltage of the optional voltage transformer PT2 (or potential transformer). Range is 100 to 500V.



From the setup menu, use **M ▲** and **P ▼** buttons to select the PT option. The screen will show the voltage PT secondary voltage value. The default value is 400V.

Press **E ▶** to enter the secondary voltage setting page and adjust as required.



Press **E ▶** to select the PT ratio screen and adjust as required. Range is 0001 to 9999.

For example, if the ratio is set to 100 then the primary voltage equals secondary voltage x100.





Please ensure all power is switched off before installing or maintaining this product.

Pulse output

This option allows you to configure the pulse output. The output can be set to provide a pulse for a defined amount of energy, active or reactive.

Use this section to set up the relay pulse output units, kWh or kVArh.



From the Set-up menu, use **M**  and **P**  buttons to select the Pulse output option.



Press **E**  to enter the selection routine. The unit symbol will flash (kWh).



Use **M**  and **P**  buttons to choose kWh or kVArh.

On completion of the entry procedure, press **E**  to confirm the setting and press **U/I**  to return to the main set up menu.

Pulse rate

Use this to set the energy represented by each pulse, rate can be set to 1 pulse per 0.01kWh/0.1kWh/1kWh/10kWh/100kWh.



This example shows one impulse=10kWh/kVArh.



Please ensure all power is switched off before installing or maintaining this product.



From the Set-up menu, use **M ▲** and **P ▼** buttons to select the Pulse Rate option.



Press **E ↵** to enter the selection routine.

The current setting will flash (10).

Options are 0.01 /0.1/1/10/100kWh/kVArh per pulse

Use **M ▲** and **P ▼** buttons to choose the pulse rate. On Completion of the entry procedure, press **E ↵** to confirm the setting and press **U/I ESC** to return to the main set up menu.

Pulse Duration

The energy monitored can be active or reactive and the pulse width can be selected as 200, 100 or 60ms.



Display showing a pulse width of 200ms.

From the set up menu, use **M ▲** the and **P ▼** buttons to select the pulse width option.



Press to enter the selection routine. **E ↵**

The current setting will flash.

Use the **M ▲** and **P ▼** buttons to choose the pulse width. On completion of the entry procedure, press the **E ↵** button to

confirm the setting and press the **U/I ESC** button to return to the main set up menu.



Please ensure all power is switched off before installing or maintaining this product.

Communication

The meter has an RS485 port which can be used to allow communication between the meter and a front end device, such as an RDM Data Manager, using a suitable Modbus interface.

Modbus Address



From the set up menu, use the **M ▲** and **P ▼** buttons to select the Address ID.

Range is from 001 to 247.



Press the **E ↵** button to enter the selection routine. The current setting will be flashing.

Use the **M ▲** and **P ▼** buttons to change the modbus address as required.

On completion of the address selection press the **E ↵** button to confirm the setting and press the **U/I ESC** button to return to the main set up menu.

Baud Rate



From the set up menu, use **M ▲** and **P ▼** buttons to select the Baud Rate option.



Press **E ↵** to enter the selection routine. The current setting will flash.



Please ensure all power is switched off before installing or maintaining this product.



Use **M ▲** and **P ▼** buttons to choose the baud rate, options are 2.4k, 4.8k, 9.6k, 19.2k or 38.4k

On completion of the entry procedure, press **E ▶** to confirm the setting and press



to return to the main set up menu.

Parity



From the Set-up menu, use **M ▲** and **P ▼** buttons to select the Parity option.



Press **E ▶** to enter the selection routine. The current setting will flash.



Use **M ▲** and **P ▼** buttons to choose parity (EVEN / ODD or NONE)

On completion of the entry procedure, press **E ▶** to confirm the setting and press



to return to the main set up menu.



Please ensure all power is switched off before installing or maintaining this product.

Stop bits



From the setup menu, use **M ▲** and **P ▼** buttons to select the Stop Bit option.



Press **E ↵** to enter the selection routine. The current setting will flash.



Use **M ▲** and **P ▼** buttons to choose Stop Bits (2 or 1).

On completion of the entry procedure, press **E ↵** to confirm the setting and press **U/| ESC** to return to the main set up menu.

CLR

The Clr parameter enables the maximum demand values of current and power to be reset.



From the set up menu, use **M ▲** and **P ▼** buttons to select the reset option.

Press **E ↵** to enter the selection routine, dIt will flash.

Press **E ↵** to confirm the setting and press **U/| ESC** to return to the main set up menu.



Please ensure all power is switched off before installing or maintaining this product.

Specifications

Measured Parameters

Voltage and Current.

Phase to neutral voltages 100 to 289V a.c.
Voltages between phases 173 to 500V a.c.
Percentage total voltage harmonic distortion (THD%) for each phase to Neutral
Percentage voltage THD% between phases.
Current THD% for each phase.

Power factor, Frequency and Maximum Demand.

Frequency in Hz	
Instantaneous power:	<ul style="list-style-type: none"> Power 0 to 3600 MW Reactive Power 0 to 3600 MVar Volt-amps 0 to 3600 MVA
Maximum demanded power since last Demand reset.	
Power factor	
Maximum neutral demand current, since the last Demand reset (for three phase supplies only).	

Energy Measurements.

Imported active energy 0 to 9999999.9 kWh
Exported active energy 0 to 9999999.9 kWh
Imported reactive energy 0 to 9999999.9 kVarh
Exported reactive energy 0 to 9999999.9 kVarh
Total active energy 0 to 9999999.9 kWh
Total reactive energy 0 to 9999999.9 kVarh

Measured Inputs

Voltage inputs through 4-way fixed connector with 2.5mm ² stranded wire capacity. Three phase four wire (3p4w) unbalanced. Line frequency measured from L1 voltage or L3 voltage.
Three current inputs (six physical terminals) with 2.5mm ² stranded wire capacity for connection of external CTs. Nominal rated input current 5A or 1A a.c. Rms.

Accuracy

Voltage	0.5% of range maximum
Current	0.5% of nominal
Frequency	0.2% of mid-frequency
Power factor	1% of unity (0.01)
Active power (W)	±1% of range maximum
Reactive power (VAr)	±2% of range maximum
Apparent power (VA)	±1% of range maximum
Active energy (Wh)	Class 1 IEC 62053-21
Reactive energy (VARh)	±2% of range maximum
Total harmonic distortion	1% up to 31st harmonic



Please ensure all power is switched off before installing or maintaining this product.

Auxiliary Supply (User to power the meter)

Two-way fixed connector with 2.5mm ² stranded wire capacity.
85 to 275V a.c. 50/60Hz $\pm 10\%$ or 120V to 380V d.c. $\pm 20\%$.
Power Consumption < 10W.

Interfaces for External Monitoring

Three interfaces are provided:	An RS485 communication channel that can be programmed for Modbus RTU protocol.
	A relay output indicating real-time measured energy (configurable).
	A pulse output (3.2kohms impedance) per kWh (not configurable).
The Modbus configuration (Baud rate etc.) and the pulse relay output assignments (kWh/kVARh, import/export etc.) are configured through the Set-up screens.	

Pulse Output

The pulse output can be set to generate pulses to represent kWh or kVARh used. The rate can be set to generate 1 pulse per:	0.01 = 10 Wh/VArh
	0.1 = 100 Wh/VArh
	1 = 1 kWh/kVARh
	10 = 10 kWh/kVARh
	100 = 100 kWh/kVARh
Pulse width 200/100/60 ms.	
Relay Rating 240V ac 50mA.	

RS485 Output for Modbus RTU

The following RS485 communication parameters can be configured from the Set-up menu:	
Baud rate	2400, 4800, 9600, 19200, 38400
Parity	none (default) /odd /even
Stop bits	1 or 2
RS485 network address	3-digit number, 1 to 247
Modbus™ Word order Hi/Lo byte order is set automatically to normal or reverse. It cannot be configured from the set-up menu.	

Reference Conditions of Influence Quantities

Influence quantities are variables that affect measurement errors to a minor degree. Accuracy is verified under a nominal value (within the specified tolerance) of these conditions.	
Ambient temperature	23°C $\pm 1^\circ\text{C}$
Input waveform	50 or 60Hz $\pm 2\%$
Input waveform	Sinusoidal (distortion factor < 0.005)
Auxiliary supply voltage	Nominal $\pm 1\%$
Auxiliary supply frequency	Nominal $\pm 1\%$
Auxiliary supply waveform (if AC)	Sinusoidal (distortion factor < 0.05)
Magnetic field of external origin	Terrestrial flux



Please ensure all power is switched off before installing or maintaining this product.

Environment

Operating temperature	-25°C to +55°C*
Storage temperature	-40°C to +70°C*
Relative humidity	0 to 90%, non-condensing
Altitude	Up to 2000m
Warm up time	1 minute
Vibration	10Hz to 50Hz, IEC 60068-2-6, 2g
Shock	30g in 3 planes
*Maximum operating and storage temperatures are in the context of typical daily and seasonal variation.	

Mechanical

DIN rail dimensions	72 x 94.5 mm (WxH) per DIN 43880
Mounting	DIN rail (DIN 43880)
Sealing	IP20 (minimum)
Material	Self-extinguishing UL94 V_0
Unit Weight	250g (meter only without CTs)

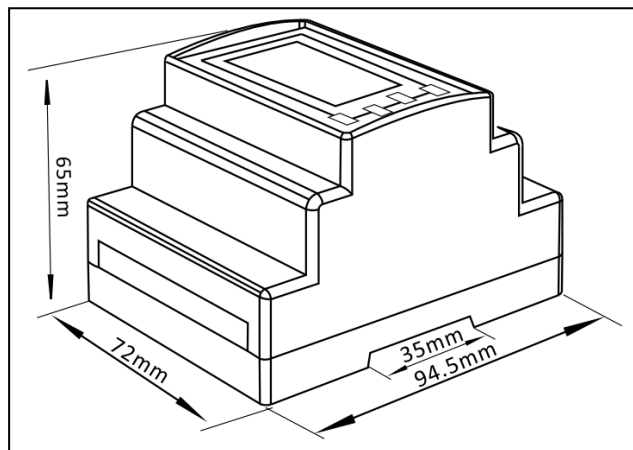

Please ensure all power is switched off before installing or maintaining this product.

Installation

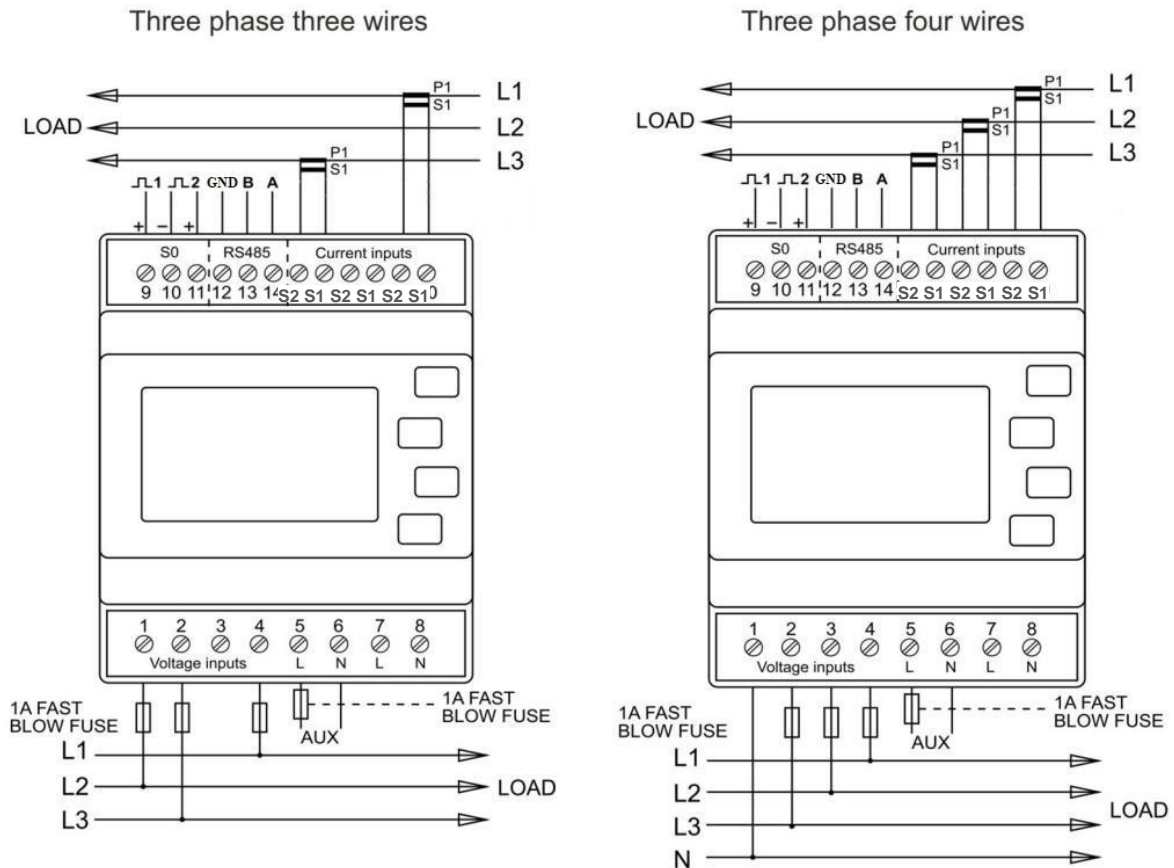

RS485 wiring

Standard RS485 wiring practices must be met. To minimise voltage reflection and potential communication errors RDM recommend terminating the ends of the line with the placement of a 120 Ohm resistor with a tolerance of +/- 1% or better.

Note: Orientation of the current transformers is important with regards to the load wires passing through them. Current must flow in the direction indicated on the current transformer.

The Aux L & N connections are used to power the meter's electronics.

Earthing of the secondary S2 current transformer connection is not required for functional purposes however it can be earthed, if required, to comply with local electrical safety regulations.



Please ensure all power is switched off before installing or maintaining this product.

Modbus Registers

Register	Name	Min	Max	Unit	Scaling	Item Type (Read Type = 4 – Read Input)		
Inputs								
0	Phase 1 line to neutral volts	-99999999	99999999	V	÷ 10	Ieee754	Invert	
2	Phase 2 line to neutral volts	-99999999	99999999	V	÷ 10	Ieee754	Invert	
4	Phase 3 line to neutral volts	-99999999	99999999	V	÷ 10	Ieee754	Invert	
6	Phase 1 current	-99999999	99999999	A	÷ 1	Ieee754	Invert	Extend
8	Phase 2 current	-99999999	99999999	A	÷ 1	Ieee754	Invert	Extend
10	Phase 3 current	-99999999	99999999	A	÷ 1	Ieee754	Invert	Extend
12	Phase 1 power	-999999	999999	kW	$\frac{\$V/1000}{\div 100}$	Ieee754	Invert	Extend
14	Phase 2 power	-999999	999999	kW	$\frac{\$V/1000}{\div 100}$	Ieee754	Invert	Extend
16	Phase 3 power	-999999	999999	kW	$\frac{\$V/1000}{\div 100}$	Ieee754	Invert	Extend
18	Phase 1 volt amps	-999999.99	999999.99	kVA	$\frac{\$V/1000}{\div 100}$	Ieee754	Invert	Extend
20	Phase 2 volt amps	-999999.99	999999.99	kVA	$\frac{\$V/1000}{\div 100}$	Ieee754	Invert	Extend
22	Phase 3 volt amps	-999999.99	999999.99	kVA	$\frac{\$V/1000}{\div 100}$	Ieee754	Invert	Extend
24	Phase 1 volt amps reactive	-999999.99	999999.99	kVAr	$\frac{\$V/1000}{\div 100}$	Ieee754	Invert	Extend
26	Phase 2 volt amps reactive	-999999.99	999999.99	kVAr	$\frac{\$V/1000}{\div 100}$	Ieee754	Invert	Extend
28	Phase 3 volt amps reactive	-999999.99	999999.99	kVAr	$\frac{\$V/1000}{\div 100}$	Ieee754	Invert	Extend
30	Phase 1 power factor	-99999999	99999999		÷ 100	Ieee754	Invert	Extend
32	Phase 2 power factor	-99999999	99999999		÷ 100	Ieee754	Invert	Extend
34	Phase 3 power factor	-99999999	99999999		÷ 100	Ieee754	Invert	Extend
36	Phase 1 phase angle	-99999999	99999999	°	÷ 1	Ieee754	Invert	Extend
38	Phase 2 phase angle	-99999999	99999999	°	÷ 1	Ieee754	Invert	Extend
40	Phase 3 phase angle	-99999999	99999999	°	÷ 1	Ieee754	Invert	Extend
42	Average line to neutral volts	-99999999	99999999	V	÷ 1	Ieee754	Invert	Extend
46	Average line current	-99999999	99999999	A	÷ 1	Ieee754	Invert	Extend
48	Sum of line currents	-99999999	99999999	A	÷ 1	Ieee754	Invert	Extend
52	Total system power	-999999.99	999999.99	kW	$\frac{\$V/1000}{\div 100}$	Ieee754	Invert	Extend
56	Total system volt amps	-999999.99	999999.99	kVA	$\frac{\$V/1000}{\div 100}$	Ieee754	Invert	Extend
60	Total system VAr	-999999.99	999999.99	kVAr	$\frac{\$V/1000}{\div 100}$	Ieee754	Invert	Extend
62	Total system power factor	-99999999	99999999		÷ 100	Ieee754	Invert	Extend
66	Total system phase angle	-99999999	99999999	Degrees	÷ 1	Ieee754	Invert	Extend
70	Frequency of supply voltages	-99999999	99999999	Hz	÷ 10	Ieee754	Invert	Extend
72	Import Wh since last reset	-99999999	99999999	kWh/MWh	÷ 1	Ieee754	Invert	Extend
74	Export Wh since last reset	-99999999	99999999	kWh/MWh	÷ 1	Ieee754	Invert	Extend
76	Import VARh since last reset	-99999999	99999999	k/MVArh	÷ 1	Ieee754	Invert	Extend
78	Export VARh since last reset	-99999999	99999999	k/MVArh	÷ 1	Ieee754	Invert	Extend
80	VAh since last reset	-99999999	99999999	k/MVAh	÷ 1	Ieee754	Invert	Extend
82	Ah since last reset	-99999999	99999999	k/MVAh	÷ 1	Ieee754	Invert	Extend
84	Total system power demand	-999999.99	999999.99	kW	$\frac{\$V/1000}{\div 100}$	Ieee754	Invert	Extend



Please ensure all power is switched off before installing or maintaining this product.

Register	Name	Min	Max	Unit	Scaling	Item Type (Read Type = 4 - Read Input)		
Inputs								
86	Max total system power demand	-999999.99	999999.99	kW	\$V/1000 / ÷ 100	Ieee754	Invert	Extend
100	Total system VA demand	-999999.99	999999.99	kVA	\$V/1000 / ÷ 100	Ieee754	Invert	Extend
102	Max total system VA demand	-999999.99	999999.99	kVA	\$V/1000 / ÷ 100	Ieee754	Invert	Extend
104	Neutral current demand	-99999999	99999999	A	÷ 1	Ieee754	Invert	Extend
106	Max neutral current demand	-99999999	99999999	A	÷ 1	Ieee754	Invert	Extend
200	Line 1 to Line 2 volts	-99999999	99999999	V	÷ 10	Ieee754	Invert	
202	Line 2 to Line 3 volts	-99999999	99999999	V	÷ 10	Ieee754	Invert	
204	Line 3 to Line 1 volts	-99999999	99999999	V	÷ 10	Ieee754	Invert	
206	Average line to line volts	-99999999	99999999	V	÷ 10	Ieee754	Invert	
224	Neutral current	-99999999	99999999	A	÷ 1	Ieee754	Invert	Extend
234	Phase 1 L/N volts THD	-99999999	99999999	%	÷ 1	Ieee754	Invert	Extend
236	Phase 2 L/N volts THD	-99999999	99999999	%	÷ 1	Ieee754	Invert	Extend
238	Phase 3 L/N volts THD	-99999999	99999999	%	÷ 1	Ieee754	Invert	Extend
240	Phase 1 Current THD	-99999999	99999999	%	÷ 1	Ieee754	Invert	Extend
242	Phase 2 Current THD	-99999999	99999999	%	÷ 1	Ieee754	Invert	Extend
244	Phase 3 Current THD	-99999999	99999999	%	÷ 1	Ieee754	Invert	Extend
248	Avge line to neutral volts THD	-99999999	99999999	%	÷ 1	Ieee754	Invert	Extend
250	Average line current THD	-99999999	99999999	%	÷ 1	Ieee754	Invert	Extend
254	Total system power factor	-99999999	99999999	°	÷ 1	Ieee754	Invert	Extend
258	Phase 1 current demand	-99999999	99999999	A	÷ 1	Ieee754	Invert	Extend
260	Phase 2 current demand	-99999999	99999999	A	÷ 1	Ieee754	Invert	Extend
262	Phase 3 current demand	-99999999	99999999	A	÷ 1	Ieee754	Invert	Extend
264	Max phase 1 current demand	-99999999	99999999	A	÷ 1	Ieee754	Invert	Extend
266	Max phase 2 current demand	-99999999	99999999	A	÷ 1	Ieee754	Invert	Extend
268	Max phase 3 current demand	-99999999	99999999	A	÷ 1	Ieee754	Invert	Extend
334	Line 1 to line 2 volts THD	-99999999	99999999	%	÷ 1	Ieee754	Invert	Extend
336	Line 2 to line 3 volts THD	-99999999	99999999	%	÷ 1	Ieee754	Invert	Extend
338	Line 3 to line 1 volts THD	-99999999	99999999	%	÷ 1	Ieee754	Invert	Extend
340	Average line to line volts THD	-99999999	99999999	%	÷ 1	Ieee754	Invert	Extend
Parameters								
Note: - The parameters are 'Read/Write' so the 'Read' type is 3 and the 'Write' type is 16								
216	Reset Log Data	0	3		÷ 1	Ieee754	Invert	



Please ensure all power is switched off before installing or maintaining this product.

Revision History

Revision	Date	Changes
1.0	28/02/2017	First Edition.
1.1	27/09/2018	Note added to start of document regarding scaling of current transformer. Updated description "press" to "press and hold".
1.2	08/12/2018	Note added regarding current flow direction on CTs and Aux power supply
1.3	09/01/2019	Note added regarding earthing of CT secondaries. Single phase wiring diagram removed as not relevant.
1.4	18/03/2019	Update to RS485 wiring, update to RDM US office address.
1.4a	25/02/2019	Modbus table updated.
1.4b	16/08/2022	ICONS updated on Screen Start Up page.



Please ensure all power is switched off before installing or maintaining this product.

Group Offices

RDM Group Head Office
80 Johnstone Avenue
Hillington Industrial Estate
Glasgow
G52 4NZ
United Kingdom
+44 (0)141 810 2828
support@resourcedm.com

RDM USA
9441 Science Center Drive
New Hope
Minneapolis
MN 55428
United States
+1 612 354 3923
usasupport@resourcedm.com

RDM Asia
Sky Park at One City
Jalan USJ 25/1
47650 Subang Jaya
Selangor
Malaysia
+60 3 5022 3188
info@rdmasia.com.my



Visit www.resourcedm.com/support for more information on RDM solutions, additional product documentation and software downloads.

While every effort is made to ensure the information given within this document is accurate, Resource Data Management Ltd shall not be liable for errors or omissions, for incidental or consequential damages, directly or indirectly, in connection with the furnishing, performance or misuse of this product or document. All specifications are subject to change without notice.

See www.resourcedm.com for terms and conditions of sales.

Copyright © Resource Data Management