

Resource
Data Management

Mercury 3 Stepper Case Controller

Installation/User Guide
Revision 3.5



PR0740-STEP

Contents

The Mercury 3 Range	4
Hardware Variants	4
Displays and Accessories	4
Compatible Network Interfaces	4
Configuration	5
Front Display Features	5
Mercury Mk3	5
Mercury Coldroom	6
Mercury Stepper Mk3 I/O Connections.....	7
Input and Output Allocation Tables	8
Switched Resistor Values	8
Transducer Input (Optional).....	9
Ordering Information	9
Setting up the controller.....	10
Setup through front buttons.....	10
Setup Function Menu (Common to all types)	10
Recommended set-up method.....	11
rtc. Real time clock (This will automatically synchronise on network systems)	11
type. Set/view controller type	11
PArA. Set/view parameters (This can be achieved at the network front end)	11
Unit. Set/view temperature unit and Probe type	11
Display	12
Display Type	12
Parameter Tables	12
Parameter Descriptions	15
Holding Current.....	20
Half Step	20
Stepper Valve Type.....	20
Valve Wiring	21
Valve State – Overdriving	21
Stepper Valve Control Using Pressure.....	21
Direct Transducer Connection.....	21
Mercury Switch (PR0018-PHI)	21
Remote pressure Direct from a Plant Pack Controller.....	22
Maximum Operating Pressure (MOP)	22
Ref Weighting	22



Please ensure all power is switched off before installing or maintaining this product.

Relay State and functional operation	22
Relay and screen states during defrost	22
Defrost Termination	22
Fan Delay after Defrost	23
Network Configuration – RS232 comms.....	23
RS485 Legacy module	23
IP Futura module.....	24
Mercury Switch.....	25
Network Configuration – IP comms	25
Viewing IO.....	26
Input / Output Table	26
Display Messages	27
Network Alarms	27
Modifying controller states.....	28
Fans Only “FanS”	28
Case Off “CASE”	28
Lights Only “Ligt”.....	28
Probe Offset.....	28
Remote Commands	29
Specification	30
Installation & Dimensions	31
Panel Cut-out and Clearances.....	31
Fixing.....	31
Dimensions	31
Cleaning	31
Appendix 1: Defrost Cycles.....	32
Appendix 2: Trim Heater Control via Mercury/Intuitive Range	33
Appendix 3 Step Speed (Frequency Hz).....	33
Disclaimer	33
Revision History	33



Please ensure all power is switched off before installing or maintaining this product.

The Mercury 3 Range

From Resource Data Management

Important! This controller requires a 24v AC or DC power supply. If used in conjunction with an Intuitive power store (PR0627) the supply must be DC only.

The Mercury Mk3 stepper controller is primarily intended for use in refrigeration display cabinets or coldroom applications. It will control the evaporator stepper valve based on the value of its temperature and/or pressure input. It has outputs to control lights, fans, suction valve, trim heaters and defrost control. It has an analogue input (4-20mA or 0-10V) for reading a pressure transducer along with two digital inputs as well as the original Mercury switched resistor digital input feature.

The controller has many features, some of which are energy saving, such as pulsed trim heaters or the case off with lights parameter (see parameter section for further details). There are several hardware variants of the Mercury Mk3 stepper controller, the choice of serial or built in IP communications along with either a remote or integral display option (see ordering information for more details).

The controller supports PT1000, NTC2K, 470R, 700R, 3K, 5K, 6K, NTC2K25, NTC10K or NTC10K(2) temperature probes. **Note:** probe types cannot be mixed.

Hardware Variants

Description	Part Number
Mercury Mk3 Stepper Valve Case Controller, Integral Display, IP Comms.	PR0740 SD IP STEP
Mercury Mk3 Stepper Valve Case Controller, Remote Display, IP Comms.	PR0740 SR IP STEP
Mercury Mk3 Stepper Valve Case Controller, Integral Display, RS232 Comms.	PR0740 SD 232 STEP
Mercury Mk3 Stepper Valve Case Controller, Remote Display, RS232 Comms.	PR0740 SR 232 STEP

Displays and Accessories

The following optional displays and accessories are available:-

Description	Part Number
Mercury Keypad Remote Display with 5m cable	PR0326
Mercury DIN Remote Display with 5m cable	PR0327
Mercury DIN Keypad Remote Display with 5m cable	PR0328
Mercury mk2 Remote Display with 5m cable	PR0725
Mercury Coldroom Display	PR0152
Intuitive Power Store (shuts the valve in the event of a power fail)	PR0627
Stepper Filter module (should be used if the standard stepper valve cable is extended)	PR0656
Pressure Transducer -1 to 20 bar with 1/4in NTP male fitting	PR0160
Pressure Transducer -1 to 20 bar 7/16in 20UNF(F) Schrader deflator	PR0161
Pressure Transducer -1 to 65 bar with 1/4in NTP male fitting	PR0162
Pressure Transducer -1 to 65 bar 7/16in 20UNF(F) Schrader deflator	PR0163

Compatible Network Interfaces

Mercury controllers which do not have an IP interface built in are capable of connecting to either a TCP/IP local area network, an RS485 Genus compatible network or they can be used in standalone mode with no network output. To connect to a network you must add the correct communications module. Connecting to any of these communication modules will automatically be detected on power up and will affect the 'Net' menu set up screens available to you. **Note** controllers with built in IP will be able to communicate to any IP switch, including the rear ports of the RDM Mercury Hub.

Description	Part Number
IP Futura (Single Mercury to IP Interface)	PR0016
RS485 Interface (Single Mercury to RS485 Interface)	PR0026
Mercury IP Switch (IP support for 10 controllers)	PR0018
Mercury IP Switch with Pressure/Humidity Inputs	PR0018-PHI



Please ensure all power is switched off before installing or maintaining this product.

Configuration

The controller gives you up to four configuration options (see 'Type' menu):-

Display value	Controller Type
3	Remote piped case controller (LT)
4	Remote piped case controller (HT)
5	Coldroom controller (LT)
6	Coldroom controller (HT)

Front Display Features

LED's:

Valve (Stepper) 

Fans (Relay 1) 

Lights (Relay 2) 

Defrost (Relay 4) 

On-Line Status 

Off - No network attached

Flashing - Attempting to Log on to network

Steady - On-line

Service
(See Parameter  18 for setup)

Alarm 

HACCP 

Mercury Mk3



Keys

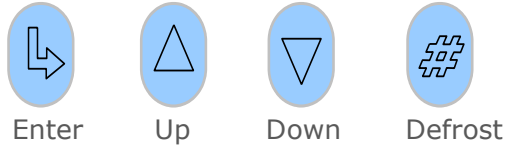

Note: Function keys illuminate when pressed, illumination is turned off 20 seconds after the key is used.

Defrost: Press and hold the defrost button to force a manual defrost

Main Display



4 character LED display, used to display temperature and status messages.









Please ensure all power is switched off before installing or maintaining this product.

Mercury Coldroom

The below display represents the remote Mercury Coldroom (PR0152) remote display

LED's:

Valve (Stepper)		
Fans		
Lights		
Defrost		
On-Line		







- Off: No network attached
- Flashing: Attempting to Log on to network
- Steady: On-line

Service 

Alarm 

HACCP 

Keys

Enter	Down	Up	Defrost Now	Not used	Not used
					

Note: Press and hold the defrost button to force a manual defrost

Main Display

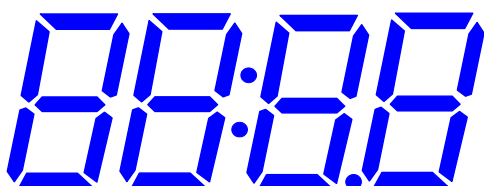

4 character blue LED display, used to display temperature and status messages.



Please ensure all power is switched off before installing or maintaining this product.

Mercury Stepper Mk3 I/O Connections

Input and Output connections are made to the back of the controller, the RS232/ Ethernet communication port is on the side. The diagram below shows the connection detail. Inputs and outputs are assigned according to the chosen configuration. See [Input/Output](#) tables for further details on connections. Below also shows you the transducer connections available.

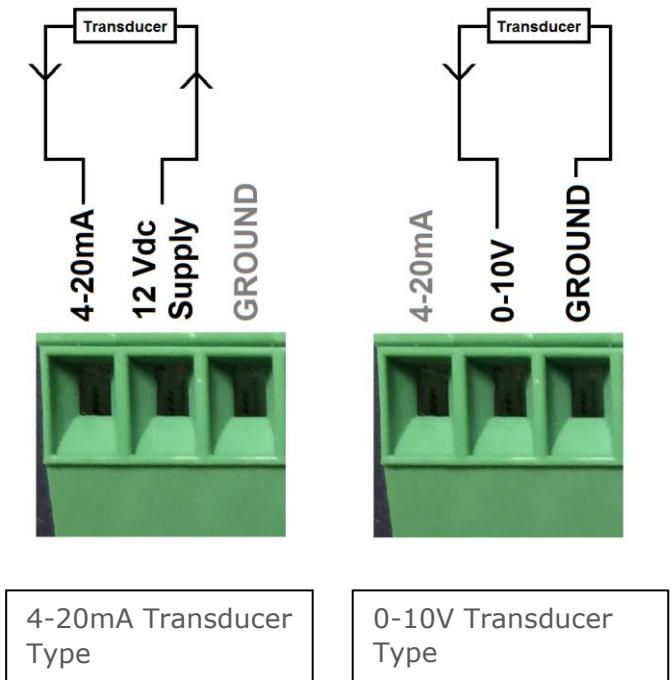
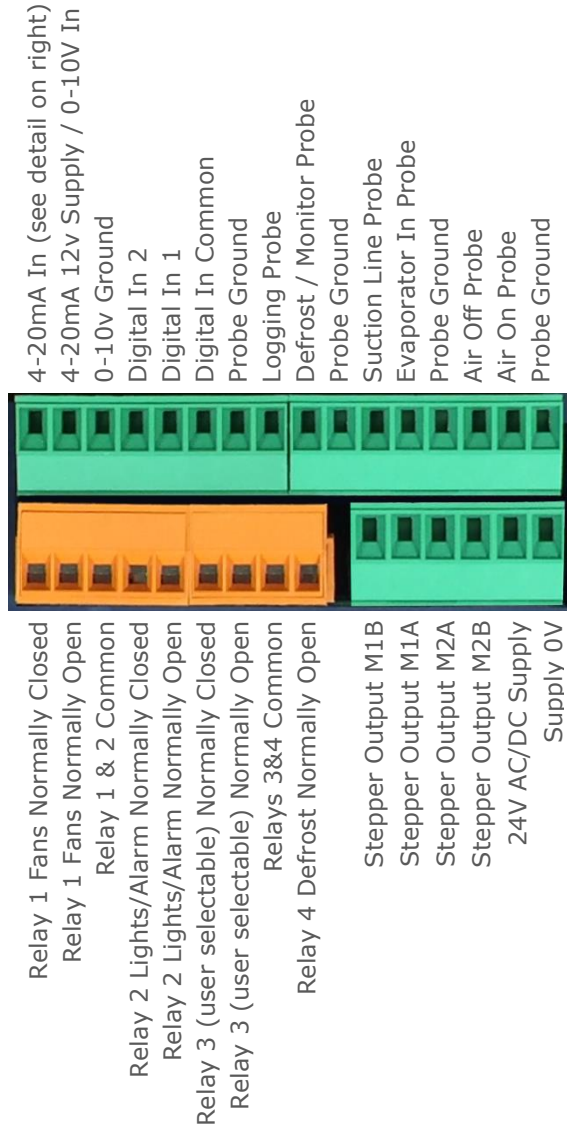

Please ensure all power is switched off before installing or maintaining this product.

Input and Output Allocation Tables

The following tables indicate; on a controller type basis, the functions of the inputs and outputs. Also shown, are the digital inputs that are derived by switching in a fixed value resistor across the input.

TYPE	Remote Case Types 3&4	Coldroom Controller Types 5&6	Alarm Action	Plant Input (Switched Resistors)
Input 1	Air on Temperature	Air on Temperature	Yes	Plant fault 3 or defrost
Input 2	Air off Temperature	Air off Temperature	Yes	Case Clean
Input 3	Evaporator Temperature	Evaporator Temperature	No	
Input 4	Suction Line Temperature	Suction Line Temperature	No	
Input 5	Defrost Termination or Monitor probe (if used)	Defrost Termination or Monitor probe (if used)	Conditional*	Door switch on types 5 & 6
Input 6	Logging Probe (If fitted)	Logging Probe (If fitted)	Conditional**	Person Trapped Alarm types 5 & 6
Variable Input	4-20mA or 0-10V Transducer	4-20mA or 0-10V Transducer	If Transducer Is Used	
Digital 1	Selectable; Plant 1 N/O, Plant 1 N/C, Case Switch, Temp Switch, Defrost, Shut Input	Selectable; Plant 1 N/O, Plant 1 N/C, Case Switch, Temp Switch, Defrost, Shut Input, Door, Person Trapped	Conditional	
Digital 2	Selectable; Plant 2 N/O, Plant 2 N/C, Case Switch, Temp Switch, Defrost, Shut Input	Selectable; Plant 2 N/O, Plant 2 N/C, Case Switch, Temp Switch, Defrost, Shut Input, Door, Person Trapped	Conditional	
Relay 1	Fans	Fans	N/A	
Relay 2	Lights or Alarm	Lights or Alarm	N/A	
Relay 3	Selectable; Suction Line Valve, Alarm Relay, Remote Relay, Liquid Line Valve.	Selectable; Suction Line Valve, Alarm Relay, Remote Relay, Liquid Line Valve.	N/A	
Relay 4	Defrost	Defrost	N/A	

* Probe will alarms if set to monitor probe in parameters.

** Probe will alarms if log probe type is set to 'Logging/Alarm' in parameters

Switched Resistor Values

If an additional digital input is required over the two dedicated digital inputs then the switched resistor function can be used, this can be turned on and off within the parameter section (P-19). When switched on, it adds the benefit of adding further digital inputs on the temperature probe inputs using fixed resistors. For wiring please see the '[Switched Resistor Wiring](#)' section. When a resistor is switched across the appropriate input, it signals to the Mercury to enable the switched resistor function (described for that input) whilst still recording the probe temperature on the input.

For the function to work, it requires specific resistors depending on the probe type used;

Probe Type	Resistor
PT1000	820Ω
NTC2K, NTC2K25, 3K	590Ω
5K, 6K	1kΩ
NTC10K	2k7Ω
NTC10K(2)	2k2Ω

The resistors used must have a tolerance of 1% or better and the resistor must have a power rating of 0.25W. For improved accuracy whilst using switched resistors RDM recommend resistors with 0.1% accuracy are used. **Note:** the switched resistor features will **not** function when using 470R or 700R probes.

The temperature range for all probe types for probe inputs which do not have a secondary function (switched resistors) is -49°C to +128°C. Inputs which have use the secondary (digital) function are restricted to -42°C to



Please ensure all power is switched off before installing or maintaining this product.

+60°C. If the full temperature range is required on all inputs and no switch resistor features are needed then please see Switch Resistor parameter P-19.

Note: switched resistors will operate in LT (Low Temperature) and HT (High Temperature) applications using PT1000, NTC2K or NTC2K25 probe types only. For all other probe types the switched resistor inputs will work in HT applications only.

Transducer Input (Optional)

There are two possible inputs that can be used for a pressure transducer, either using the 0-10v or 4-20mA input. Please consult the [I/O Connections](#) for wiring. Depending on the type of transducer (0-10v or 4-20mA) the input type can be chosen using the Evap Select parameter p-17.

Ordering Information

When ordering a Mercury Mk 3 controller the following ordering scheme can be used to purchase the desired hardware configuration.

PR0740- S **Y Z** STEP

Y	Description
D	Local/ Integral Display
R	Remote Display

Z	Description
IP	Ethernet Comms
232	RS232 Comms

Example

To order a Mercury MK3 controller with Stepper Valve, Remote display and IP comms;

PR0740 – S **R IP** STEP



Please ensure all power is switched off before installing or maintaining this product.

Setting up the controller

Access to the controller can be achieved by several ways;

Serial Communications Variant

- Through the front mounted buttons of the display
- Direct access by PC into the serial comms port. This requires a software package available on the RDM website.
- Through legacy front end panels on 485 networks.
- Through the RDM Data Manager.
- Across an IP network (Current controller IP address required).

Ethernet Communications Variant

- Through the front mounted buttons of the display.
- Across an IP network (Current controller IP address required).
- Through the Data Manager.

Setup through front buttons



To enter setup mode, hold the **Enter** and **Down** buttons together for approximately 3 seconds until the message "Ent" appears on the display. Now press the Enter button again to enter the function menu. IO will be displayed. Scroll up or down to go through the list.

Setup Function Menu (Common to all types)

Display	Option	Explained in Paragraph	Display	Option	Explained in Paragraph
IO	View Inputs / Outputs and States	Input / output table	SoFt	View software version	
PArA	Set/View Parameters	Set view parameters	FANS	Toggle Fans Only mode	Fans Only
Unit	Probe type and Celsius/Fahrenheit option	Set View Unit	CASE	Toggle Case Off mode	Case Off
diSP	Display whole units or decimal	Display	Ligt	Toggle Lights Only mode	Lights Only
dtYP	Display Type	Display Type	OFSt	Probe Offset	Probe Offset
tyPE	Set/View Controller Type	Set/view controller type	tEst*	Test Mode	See Note Below
rtc	Set/view Clock (rtc = Real Time Clock)	Real Time Clock	ESC	Exit Setup mode	
nEt	Set/view network configuration	Network Configuration			

***Note:** When first powered up the controller will have the 'tEst' option in the menu setup. This allows the user to toggle the relays for testing purposes. Upon entering the menu, the display will show r-01 (relay 1) to r-05 (relay 5), select the desired output and toggle the value from 0 to 1 (confirm by pressing enter) to switch the selected relay.

This option is only available for 30 seconds after power up. After this time, the menu setup will return to its standard options.



Please ensure all power is switched off before installing or maintaining this product.

Recommended set-up method

If you are not connecting to a network and want to set up the controller through the buttons we recommend you use the following order from the function menu.

rtc. Real time clock (This will automatically synchronise on network systems)

- a. Use the up or down buttons to scroll through the display until the display reads "rtc"
- b. Press enter. The display will show "t-1". press enter again
- c. Scroll hours up or down (0 – 23) press enter
- d. Use up button to select "t-2", press enter
- e. Scroll minutes up or down (0 – 59) press enter
- f. Repeat for t-3 (seconds 0 – 59)
- g. Repeat for t -4 (Days up to 31)
- h. Repeat for t -5 (months up to 12)
- i. Repeat for t -6 (Year up to 99)
- j. Use up button to display "ESC", press enter to display "rtc"

Time clock is now set

type. Set/view controller type

- a. From the function menu scroll to select 'type', press enter
- b. Use the up/ down buttons to scroll through case/ coldroom configuration types. (see [configuration table](#) on page 4)
- c. Press enter.
- d. Scroll to select "ESC"
- e. Press enter

Controller type configuration is now set

PArA. Set/view parameters (This can be achieved at the network front end)

- a. From the function menu, scroll to select 'PArA'
- b. Pressing Enter while PArA is displayed will enter the parameter menu.
- c. The first parameter option will be displayed as P-01. Pressing the Up or Down button will present the other parameter options P-02, P-03 etc. See the [parameter list](#) below to find what parameter number corresponds to which actual parameter.
- d. Pressing the Enter button will show the current value of the selected parameter.
- e. Press Up or Down to modify the value and press Enter again to save the value.
- f. The parameter list number will be displayed again.
- g. Two other options are present in the parameter menu – dFLt and ESC. Selecting ESC will exit the setup mode and save all changes.
- h. Selecting dFLt will reset all parameters back to the default values for the current type of controller

Unit. Set/view temperature unit and Probe type

From the function menu scroll to, and select Unit. Press enter and the value will be displayed: -

Probe Types

0 for PT1000 Celsius	10 for NTC2K25 Celsius
1 for PT1000 Fahrenheit	11 for NTC2K25 Fahrenheit
2 for NTC2K Celsius	12 for 5K Celsius
3 for NTC2K Fahrenheit	13 for 5K Fahrenheit
4 for 470R Celsius	14 for 6K Celsius
5 for 470R Fahrenheit	15 for 6K Fahrenheit
6 for 700R Celsius	16 for NTC10K Celsius
7 for 700R Fahrenheit	17 for NTC10K Fahrenheit
8 for 3K Celsius	18 for NTC10K(2) Celsius (USA NTC10K)
9 for 3K Fahrenheit	19 for NTC10K(2) Fahrenheit (USA NTC10K)

Use the up or down keys to select the units and press enter.

This function is now complete



Please ensure all power is switched off before installing or maintaining this product.

Display

From the function menu scroll to and select 'diSP'.
Press enter and one of the following values will be shown: -

- 0. Controller display will show the whole number and tenths value of a temperature reading. (Default)
- 1. Controller display will show temperatures as a whole number.

Display Type

From the function menu scroll to and select dtYP. Press enter and one of the following values will be shown: -

- 0. Controller will be set to use a Mercury display.
- 1. Controller will be set to use a Coldroom display.

Note: The software defaults to 0 for the Mercury display. If using a Mercury 1 display, changing from type 1 to 0 needs to be done through the webpage and can't be done through the display.

Parameter Tables

Not all parameters apply to all controller types. For example P-80 is the Door Alarm Delay which only applies to the types 5 & 6. This parameter will not appear if the controller is set to types 3 or 4 (Case controller). In the following table, the type columns on the right hand side will be greyed out if that parameter does not apply to that controller type.

Number	Parameter	Range °C (°F)	Step	Units	Default LT °C(°F)	Default HT °C(°F)	Type 3&4	Type 5&6
P-01	Cut-in Temp.	-42 to 30 (-43.6 to 86)	0.1	Deg	-20 (-4)	0.0 (32)	✓	✓
P-02	Diff.	0 to 10 (0 to 18)	0.1	Deg	2 (3.6)	1.5 (2.7)	✓	✓
P-03	Control Weight	0 to 100	1	%	50	50	✓	✓
P-04	Display Weight	0 to 100	1	%	50	50	✓	✓
P-05	Alarm Weight	0 to 100	1	%	0	0	✓	✓
P-08	Superheat Ref	4 to12 (7.2 to 21.6)	0.1	Deg	6 (10.8)	6 (10.8)	✓	✓
P-09	Response On	1 to 30	1		10	10	✓	✓
P-10	Response Off	1 to 30	1		10	10	✓	✓
P-11	Control Type	0 = EEV 1 = EET 2 = EEV/EET	1		0	0	✓	✓
P-51	EEV Min Opening	0 - 100%	1	%	10	10	✓	✓
P-52	Superheat Problem	0 - 12 (0 - 21.6)	0.1	Deg	0	0	✓	✓
P-53	Superheat EEV Problem Opening	0 - 100%	1		10	10	✓	✓
P-54	Superheat EEV Problem Time	00:00 to 99:00	01:00	mm:ss	03:00	03:00	✓	✓
P-56	EEV Start Opening	0 - 100%	1	%	10	10	✓	✓
P-55	Ave Valve Opening	0 - 100%	1	%	100	100	✓	✓
P-57	EEV Divide Value	0 - 100%	1		50	50	✓	✓
P-12	Relay 3 Mode (Case)	0 = Suction Line, 1 = Trim Heater, 2 = Alarm, 3 = Remote, 4 = Trim Hub, 5 = LLV	1		0	0	✓	
	Relay 3 Mode (Coldroom)	0 = Suction Line, 1 = Alarm, 2 = Remote, 3 = LLV	1		0	0		✓
P-13	Trim in Defrost	0 (Off), 1(On)			0	0	✓	
P-14	Trim Level	0 to 100	1	%	100	100	✓	
P-85	Key-switch Mode	0 = Case Off, 1 = Fans only, 2 = toggle	1		0	0	✓	✓
P-87	Control Probe type	0 = Use Air on Probe, 1 = Use Log Probe	1		0	0	✓	✓
P-90	Resistor Case Off	0 (Disabled), 1(Enabled)			0	0	✓	✓



Please ensure all power is switched off before installing or maintaining this product.

P-92	Fans temperature mode	0 = Off, 1 = Temperature, 2 = Over-temperature, 3 = Temp/OT	1		0	0	✓	✓
P-93	Fans Off Temperature	-42 to 30 (-43.6 to 86)	0.1	Deg	-10 (14)	8 (46.4)	✓	✓
P-83	Fan Control	0 = Off, 1 = Run, 2 = Pulse	1		1	1		✓
P-78	Fan Pulse On	00:00 to 99:00	01:00	mm:ss	05:00	05:00		✓
P-79	Fan Pulse Off	00:00 to 99:00	01:00	mm:ss	30:00	30:00		✓
P-15	Probe 5 Select	0 = Defrost, 1 = Monitor	1		0	0	✓	✓
P-16	Relay 2 Mode	0 = Lights, 1 = Alarm	1		0	0	✓	✓
P-17	Evap. Select	0 = Local, 1 = Rem1, 2 = Rem2, 3 = Rem3, 4 = Trans V, 5 = Trans mA	1		0	0	✓	✓
P-97	Control Fail Valve	0 to 100%	0.1	%	0	0	✓	✓
P-29	Probe 1 Resistor Function	0 = Plant fault 3 N/O, 1 = Plant fault 3 N/C, 2 = Ext Defrost	1		0	0	✓	✓
P-18	Service Int time	0 to 128	1	KHrs	60	60	✓	✓
P-19	Switch Resistors	0 (Off), 1 (On)			1	1	✓	✓
P-98	Lights Case Off	0 (Off), 1 (On), 2 (Unused)			0	0	✓	
P-77	Man Stop Valve/Fans	0 (Off), 1 (On)	1		0	0		✓
P-100	Digital Input 1 Mode	Types 3&4; 0 =Plant 1/2 N/O 1 =Plant 1/2 N/C 2 =Case Switch 3 =Temp Switch 4 =Defrost 5 = Shut Input	1		0	0	✓	✓
P-101	Digital Input 2 Mode	Types 5&6; 0 =Plant 1/2 N/O 1 =Plant 1/2 N/C 2 =Case Switch 3 =Temp Switch 4 =Defrost 5 = Shut Input 6 =Door 7 =Man Trap	1		0	0	✓	✓
P-102	Cut In Offset	-30 to 30	0.1		5.0	5.0	✓	✓
P-20	Alarm Delay	00:00 to 99:00	01:00	mm:ss	20:00	20:00	✓	✓
P-21	UT Alarm	-49 to 60 (-56.2 to 140)	0.1	Deg	-30 (-22)	-2 (28.4)	✓	✓
P-22	OT Alarm	-49 to 60 (-56.2 to 140)	0.1	Deg	-15 (5)	5 (41)	✓	✓
P-23	Log Probe Type	0 (Off), 1 (Logging), 2 (Logging/Alarm)			Off	Off	✓	✓
P-24	Slug Log Probe	0 (Off), 1 (On)			Off	Off	✓	✓
P-25	Log Alarm Delay	00:00 to 99:00	01:00	mm:ss	20:00	20:00	✓	✓
P-26	Log UT Alarm	-49 to 60 (-56.2 to 140)	0.1	Deg	-35 (-31)	-1 (30.2)	✓	✓
P-27	Log OT Alarm	-49 to 60 (-56.2 to 140)	0.1	Deg	-12 (10.4)	6 (42.8)	✓	✓
P-28	Monitor OT Alarm	-49 to 60 (-56.2 to 140)	0.1	Deg	20 (68)	20 (68)	✓	✓
P-58	Probe 2 Alarm	0 (Off), 1 (On)			Off	Off	✓	✓
P-40	Defrost Mode	0 (Local), 1 (Remote), 2 (External)			Local	Local	✓	✓
P-41	Defrost Start	00:00 to 23:59	00:01	hh:mm	01:00	01:00	✓	✓
P-42	Defrosts per Day	0 to 8	1		6	6	✓	✓
P-43	No Defrost Time	0 to 25	1	hours	12	12	✓	✓
P-44	Def Terminate Temp.	-42 to 30 (-43.6 to 86)	0.1	Deg	14 (57.2)	10 (50)	✓	✓
P-45	Def Min Time	00:00 to 99:00	01:00	mm:ss	05:00	05:00	✓	✓
P-46	Def Max Time	00:00 to 99:00	01:00	mm:ss	24:00	24:00	✓	✓



Please ensure all power is switched off before installing or maintaining this product.

P-47	Drain Down	00:00 to 24:00	00:15	mm:ss	01:30	01:30	✓	✓
P-48	Recovery Time	00:00 to 99:00	01:00	mm:ss	30:00	30:00	✓	✓
P-89	Pump Down Time	00:00 to 99:00	01:00	mm:ss	00:00	00:00	✓	✓
P-86	Fan Delay mode	0 = Time, 1 = Temp	1		0	0	✓	✓
P-49	Fan Delay Time (Cabinets)	00:00 to 99:00	01:00	mm:ss	00:00	00:00	✓	
	Fan Delay Time (Coldroom)	00:00 to 99:00	01:00	mm:ss	03:00	03:00		✓
P-88	Fan Delay Temp	-42 to 30 (-43.6 to 86)	0.1	Deg	-20 (-4)	0.0 (32)	✓	✓
P-50	Fans In Defrost	0 (Off), 1 (On)			On	On	✓	
P-91	Defrost Type	0 (Electric), 1(Gas)	1		0	0	✓	✓
P-94	Defrost Hold	0 (Off), 1 (On)			Off	Off	✓	✓
P-95	Defrost Skip	0 (Off), 1 (On)			Off	Off	✓	✓
P-96	Defrost Skip Time	00:00 to 99:00	01:00	mm:ss	12:00	12:00	✓	✓
P-120	Disp Def Button	0 (Off), 1 (On)	1		On	On	✓	✓
P-80	Door Alarm Delay	00:00 to 99:00	01:00	mm:ss	20:00	20:00		✓
P-81	Door Closes Valve	0 (No), 1 (Yes)			No	No		✓
P-82	Door Stops Fan	0 (No), 1 (Yes)			No	No		✓
P-60	Lights Mode	0 (Local), 1 (Remote), 2 (Man Off),3 (Man On)			Local	Local	✓	✓
P-61	Sun Lights On	00:00 to 23:59	00:01	hh:mm	08:00	08:00	✓	✓
P-62	Sun Lights Off	00:00 to 23:59	00:01	hh:mm	20:00	20:00	✓	✓
P-63	Mon Lights On	00:00 to 23:59	00:01	hh:mm	08:00	08:00	✓	✓
P-64	Mon Lights Off	00:00 to 23:59	00:01	hh:mm	20:00	20:00	✓	✓
P-65	Tue Lights On	00:00 to 23:59	00:01	hh:mm	08:00	08:00	✓	✓
P-66	Tue Lights Off	00:00 to 23:59	00:01	hh:mm	20:00	20:00	✓	✓
P-67	Wed Lights On	00:00 to 23:59	00:01	hh:mm	08:00	08:00	✓	✓
P-68	Wed Lights Off	00:00 to 23:59	00:01	hh:mm	20:00	20:00	✓	✓
P-69	Thu Lights On	00:00 to 23:59	00:01	hh:mm	08:00	08:00	✓	✓
P-70	Thu Lights Off	00:00 to 23:59	00:01	hh:mm	20:00	20:00	✓	✓
P-71	Fri Lights On	00:00 to 23:59	00:01	hh:mm	08:00	08:00	✓	✓
P-72	Fri Lights Off	00:00 to 23:59	00:01	hh:mm	20:00	20:00	✓	✓
P-73	Sat Lights On	00:00 to 23:59	00:01	hh:mm	08:00	08:00	✓	✓
P-74	Sat Lights Off	00:00 to 23:59	00:01	hh:mm	20:00	20:00	✓	✓
P-30	Broadcast ID	0 to 999	1	-	0	0	✓	✓
P-31	Refrigerant	0 to 27, See Refrigerant Table	1	-	0	0	✓	✓
P-110	Ref weight	0 to 100%	1	%	0	0	✓	✓
P-32	Pressure Units	0 = Absolute 1 = Gauge	1	-	0	0	✓	✓
P-33	Evap Offset**	0.0 to 5.0 (0 to 72)	0.1	-	0.0	0.0	✓	✓
P-34	Glide	0.0 to 10.0	0.1	Deg	0.0	0.0	✓	✓
P-35	Trans Span***	-3.4 to 180.0	0.1	Bar	13.8	13.8	✓	✓
P-36	Trans Offset***	-3.4 to 180.0	0.1	Bar	0.0	0.0	✓	✓
P-37	MOP Cut-in	-3.4 to 180.0	0.1	Deg	3.4	3.4	✓	✓
P-38	MOP Diff	-3.4 to 180.0	0.1	Deg	0.3	0.3	✓	✓
P-39	MOP Delay	00:00 to 02:00	00:01	mm:ss	00:05	00:05	✓	✓
P-150	Custom A1	-999 - 999	1		0	0	✓	✓
P-151	Custom B1 Hi	-999 - 999	1		-220	-220	✓	✓
P-152	Custom B1 Lo	0 - 999	1		384	384	✓	✓
P-153	Custom C1	-999.9 - 999.9	0.1		262.5	262.5	✓	✓
P-154	Custom A2	-999 - 999	1		0	0	✓	✓
P-155	Custom B2 Hi	-999 - 999	1		-220	-220	✓	✓
P-156	Custom B2 Lo	0 - 999	1		384	384	✓	✓
P-157	Custom C2	-999.9 - 999.9	0.1		262.5	262.5	✓	✓
P-120	Valve Type	0=Carel, 1=Sporlan1, 2=Sporlan2 3=Alco, 4=Other*	1	---	0	0	✓	✓
P-121	Step Max	0 to 6800 See: Valve type	1	---	480	480	✓	✓
P-122	Step Close	0 to 6800 See: Valve type	1	---	500	500	✓	✓
P-123	Step Speed	0 to 6800 See: Valve type	1	Hz	50	50	✓	✓
P-124	mA Peak	0 to 500 See: Valve Type	1	mA	450	450	✓	✓
P-125	Half Step	0 (Off),1 (On) See: Valve Type	1	---	0	0	✓	✓



Please ensure all power is switched off before installing or maintaining this product.

P-126	mA Hold	0 to 500	1		0	0	✓	✓
P-127	Shut Speed	0 to 6800	1	Hz	200	200	✓	✓
P-128	Overdrive Time	1 to 25	1	hours	8	8	✓	✓
P-129	Shut Enable	0 (Off), 1 (N/C), 2 (N/O)	1		0	0	✓	✓
P-130	Shut Time	00:00 to 99:00	01:00	mm:ss	04:00	04:00	✓	✓
dFLt	Restore defaults						✓	✓

* Transducer Span and Offset allows for the full range of the transducer to be used by the Mercury Controller. 'Span' is the full range of the transducer, 'Offset' is the value below zero.

Example: RDM PR0160 with range -1 bar to 20 bar, Span would be 21 bar, Offset would be -1 bar.

Refrigerant Table for P-31

No.	Gas	No.	Gas	No.	Gas	No.	Gas	No.	Gas
0	None	6	R401A	12	R407A	18	R507	24	R449A
1	Custom	7	R401B	13	R407B	19	R717	25	R513A
2	R32	8	R401C	14	R407C	20	R290	26	R454C
3	R134a	9	R402A	15	R500	21	R744	27	R455A
4	R142B	10	R402B	16	R502	22	R407F		
5	R227	11	R404A	17	R503	23	R410A		

Parameter Descriptions

Number	Parameter	Description
P-01	Cut-in Temp	Temperature at which the valve will switch on.
P-02	Diff	Differential temperature below the cut-in temperature. The valve switches off when below this temperature
P-03	Control Weight	Percentage of the Air-On temperature that is used to calculate the control temp. The remaining percentage will be used on the Air-Off temperature Example, P-03 set to 30% Control temp = 30% Air-on + 70% Air-off
P-04	Display Weight	As above only applied to the display temperature
P-05	Alarm Weight	Percentage of the Air-On temperature that is used to calculate the over temperature alarm.
P-08	Superheat Ref	The controller will attempt to maintain this superheat value
P-09	Response on	Allows the user to adjust the valve opening rate in relation to superheat change, with 30 providing the quickest response and 1 providing the slowest response.
P-10	Response off	Allows the user to adjust the valve closing rate in relation to superheat change, with 30 providing the quickest response and 1 providing the slowest response.
P-11	Control Type	Allows the user to select either EEV control, EET control or EEV/EET control. Note the Evaporator Temperature probe should be fitted to the coldest point in the evaporator. EEV uses the superheat as its main reference with the cabinet temperature as a secondary control. EET use the cabinet temperature as its main reference with the superheat as a secondary control. EEV/EET uses cabinet temperature as the main control until the SH gets close to the SH reference point, then it switches to EEV control, it switches back to EET control when the SH reference is satisfied.
P-51	EEV Minimum Opening	Sets the minimum valve opening level, during normal operation the valve will not go below this level. (Default 10%) If using a pressure transducer as opposed to temperature probes only, then the Minimum value opening should be set at 0%
P-52	Superheat Problem	Sets the point at which the controller will go to the "EEV Problem" state due to the superheat value. For example if this parameter is set to 0 Degrees and the Superheat value falls to 0 degrees or below, for the duration of P-54, then the controller will enter the superheat problem state which will force the valve opening to the value set in P-53.
P-53	Superheat EEV Problem Opening	Sets the valve open position when entering the "Superheat EEV Problem" state.



Please ensure all power is switched off before installing or maintaining this product.

P-54	Superheat EEV Problem Time	Sets the time the controller stays in the "Superheat EEV Problem" state.
P-56	EEV Start Opening	Sets the valve opening % which is used after a defrost or when the controller exits a problem state for, example Superheat EEV Problem state
P-55	Average Valve Opening	Normally the valve during recovery will open to the last average position. This setting allows for that value to be reduced by said percentage. For example if the average valve opening is calculated as 80% and P-55 is set to 50% then the valve will open at 40%.
P-57	EEV Divide value	This parameter takes effect when the controller is used in conjunction with a pressure transducer. When an MOP (maximum operating pressure) alarm is generated the controller reduces the maximum valve opening to this percentage. For example if this parameter is set to 50% and the MOP alarm is generated then the maximum valve opening will be limited to 50%. (When P-103 is set to "on" then the divide value will be used all the time regardless of MOP). Note P-51 EEV Minimum opening overrides the valve output operation and the valve will not open below this setting. Please see MOP note. Please note parameters P-51 through to P-57 should not be altered without first understanding the effects they may have on the case operation. If incorrectly set they may have undesired affects.
P-12	Relay 3 Mode	Relay 3 can be a Suction, Trim Heater, Alarm, Remote, Trim Hub relay or Liquid Line Valve (LLV) <ul style="list-style-type: none"> ➤ Suction – set for Suction Line Valve operation. ➤ Trim Heater – set as trim relay which pulses in accordance with P-14 or the Data Manager energy feature trim control. ➤ Alarm – The alarm relay is energised for no alarm. Use the NC and Common for "Loop make" on alarm or use the NO and Common for "Loop break" on alarm. ➤ Remote – The relay is available for remote purposes such as the Data Manager GP timer channel or Data Builder software. ➤ Trim Hub – Relay is pulsed in accordance with the Trim Control feature present in the Mercury Switch (PR0018-PHI). Please see the Mercury switch user document for further details. ➤ LLV – The relay operates a liquid line valve which is open when the stepper valve is operating and closed when the stepper valve is at 0% (during defrost for example)
P-13	Trim in Defrost	Allows the trims to be off or on during a defrost.
P-14	Trim Level	Sets a percentage level, of a 5-minute period, to pulse the trim heater relay off/on. Example: - P-14 set to 50% = 2.5 minutes on, 2.5 minutes off. If the controller is networked to a Data Manager operating the energy feature Trim Control then the Data Manager feature will override this parameter setting. Please refer to the Data Manager user document for further details. Note the trims are turned off when an over temperature alarm occurs.
P-85	Key-switch Mode	Allows the keys switch to be: - <ul style="list-style-type: none"> ➤ Single turn for case off (Case off mode) ➤ Single turn for Fans only (Fans Mode) ➤ Single turn for case off, double turn for fans only (Toggle mode)
P-87	Control Probe type	Switches between using the air-on probe and the Logging probe. Note the control and display temperature will still be a derivative of the weighted Average of the control probe + Air-off probe
P-90	Resistor Case Off	Turns on/off the switched resistor case off function
P-92	Fans temperature mode	Allows the user to set the fans to turn off when: - <ul style="list-style-type: none"> ➤ A pre-determined temperature is reached (P93) ➤ When an over-temperature alarm is present ➤ When either P93 is reached or an OT alarm is present
P-93	Fans Off Temperature	Temperature for the above (P92) operation. Note the defrost termination probe is the source of the temperature reading used in this feature. If the defrost termination probe isn't fitted then a similar process to P-44 is used.
P-83	Fan Control	This feature allows for coldroom fans to be stopped when the coldroom is down to temperature thus saving energy. <ul style="list-style-type: none"> ➤ Run – fans operate as per the normal control strategy. ➤ Pulse – When the valve closes the fans will stop when the Fan Pulse On parameter (P-78) time expires. The fans then remain off for the Fan Pulse Off time (P-79). When the parameter Fan Pulse Off time expires the fans come back on for the Fan Pulse on time. The cycle then repeats. The fans resume normal operation if the valve operates. The fans pulse on/off to ensure the circulation of air within the coldroom. ➤ Off – When the valve closes the fans stay on for the Fan Pulse On (P-78) time before going off until the LLV next operates. Placement of the temperature control probes is important when using this feature
P-78	Fan Pulse On	The duration of the fans are pulsed on in Fan Control.



Please ensure all power is switched off before installing or maintaining this product.

P-79	Fan Pulse Off	The duration of the fans are pulsed off in Fan Control.
P-15	Probe 5 Select	This input can be used as a defrost termination probe (default) or as a monitor probe with an OT alarm level (P-28)
P-16	Relay 2 mode	This changes the function of relay 3 from Lights (default) to an alarm relay. The alarm relay is energised for no alarm. Use the NC and Common for "Loop make" on alarm or use the NO and Common for "Loop break" on alarm.
P-17	Evap. Select	This allows the control algorithm to use a remote pressure input converted to temperature in place of the evaporator in value. In the event of no remote value being received, the control algorithm will revert to using the evaporator in probe value until the remote value is restored. Please see : Valve Control Using Pressure
P-97	Control Fail Valve Value	This value is used in the event of a control probe fail; In the control algorithm the valve will remain at this opening until the probe fault has been cleared. Please note the incorrect setting of this value may result in flood back causing damage to the pack compressors. Do not adjust this parameter if you are unsure of the consequences.
P-29	Probe 1 Resistor Function	Selects whether the switched resistor invokes either a Plant fault or an External Defrost.
P-18	Service Interval Time (Run Hours)	Time (in 1000 x hours) before the service icon (Spanner icon) comes on. The Run Hours timer increments based on the number of hours the controller has been powered up and running. Reset the spanner icon to off by changing this parameter to 0 and then back to the desired service interval. This process also resets the Run Hours value to 0. To view the current Run Time value refer to the I/O list.
P-19	Switch Resistors	Enables switched resistors to be used for Plant Faults, External Defrosts, Case Clean, Man Trap, Door Switch See : Switched Resistor Values
P-77	Man Stop Valve/Fans	When man trap input is activated the valve closes and fans are stopped. Normal operation resumes when the mantrap input is deactivated.
P-100 P-101	Digital 1 Mode Digital 2 Mode	Sets the status input type for the two Digital Inputs; <ul style="list-style-type: none"> ➤ Plant 1/2 – When the DI is activated, it would alarm Plant Fault 1/2 (N/O or N/C) ➤ Case Switch – Would carry out the operation set on the 'Key Switch mode' (p-85) ➤ Temp Switch – Adds temperature setpoint offset value set in P-102 ➤ Defrost – The DI activation would signal the unit to go into a defrost (must be set to remote df). ➤ Shut Input – Used in conjunction with the Intuitive power store (PR0627), closes the valve in the event of a power fail. ➤ Door – The DI activation would signal if the door is open or closed. ➤ Person Trap – If the DI signal is received, a Person Trap alarm is activated.
P-20	Alarm Delay	Delay for the over and under-temperature alarms
P-21	UT Alarm	Under temperature alarm set point. This alarm uses the control temperature.
P-22	OT Alarm	Over temperature alarm set point. This alarm uses the air-off temperature.
P-23	Log Probe Type	Allows the user to set the logging probe mode: - <ul style="list-style-type: none"> ➤ Off ➤ Logging with no alarms ➤ Logging with alarms
P-24	Slug Log Probe	Applies a damping factor. This can be used to make a standard probe have the same temperature response as a logging probe.
P-25	Log Alarm Delay	Delay for the Logging probe over and under-temperature alarms
P-26	Log UT Alarm	Logging probe under temperature alarm set point
P-27	Log OT Alarm	Logging probe over temperature alarm set point
P-28	Monitor OT Alarm	Monitor probe over temperature alarm set point
P-58	Probe 2 Alarm	Allows user to disable Probe 2 alarms if probe is not fitted.
P-40	Defrost Mode	Allows the user to set the defrost mode: - <ul style="list-style-type: none"> ➤ Local (Uses the internal parameters P-41 and P-42) ➤ Remote (Requires a defrost schedule in the front end) ➤ External (uses a switched resistor in input 1). When this signal is present a defrost is initiated. <p>Note: - If the external defrost signal is not removed then the controller will defrost according to the "No Defrost" time and a missed defrost alarm will be generated. See P-29 for external defrost signal setup.</p>
P-41	Defrost Start	When defrost mode is set to "Local", this is the start time for the 1 st defrost
P-42	Defrosts per Day	When defrost mode is set to "Local", this is the number of defrosts per day equally spaced from the start time.
P-43	No Defrost Time	If the controller misses a defrost command for any reason, a defrost will initiate after this time has elapsed from the last defrost. Normally set to 2 hours over the normal defrost period.



Please ensure all power is switched off before installing or maintaining this product.

P-44	Def Terminate	The defrost will terminate (defrost control relay off) when the temperature of the defrost termination probe reaches this value. If the "defrost termination" probe is not fitted, defrost termination will occur when: - The "coil in" probe reaches the set point (If fans are selected as "off during defrost") Or The "air off" probe reaches the set point (If fans are selected as "on during defrost"). If the "coil in" probe is not fitted, the "air off" probe will be used.
P-45	Def Min Time	Minimum time that a defrost will use (Defrost can't terminate until this time has elapsed. If termination temperature is reached during this period, the defrost control relay is turned off, but the controller will not continue the defrost cycle until the end of the defrost min period)
P-46	Def Max Time	Time period after defrost minimum that defrosts are allowed to terminate
P-47	Drain Down	A period after defrost max to allow the draining of any surplus water
P-48	Recovery Time	The valve is opened at the start of this period to allow the temperature to recover to the normal operating point. This period also inhibits the OT alarm. Note that if the air-off temperature is still above the OT alarm setpoint when this period expires, an immediate OT alarm occurs; there is not a further alarm delay.
P-89	Pump Down Time	Time period before the defrost min period to allow for a pump down
P-86	Fan Delay mode	This parameter allows the fans start after a drain-down period to be delayed, either by time (P-49) or when the temperature point (P-88) is reached. This parameter uses the same probe strategy as the defrost terminate.
P-49	Fan Delay	Time after a drain-down period before the fans start if P-86 is set to time
P-88	Fan Delay Temp	Temperature at which the fans start after a drain-down period when P-86 is set to temperature.
P-50	Fans In Defrost	Allows the user to set the fans on or off in defrost. Note if the fans are set to on in defrost, they will go off for the drain-down period and then follow the P-86 rules.
P-94	Defrost Hold	Turns the defrost hold feature on and off. When switched on, the controller can be held in defrost until a remote command from the front end starts the recovery process.
P-95	Defrost Skip	Allows user to enable/disable defrost skip. This feature allows the controller to skip defrosts. If the current defrost terminates on temperature then the controller will skip the next scheduled defrost providing the previous defrost terminated before the defrost skip time (P-96). Operates only when the controller is set to local defrost scheduling.
P-96	Defrost Skip Time	Time factor used in defrost skip. The previous defrost has to terminate before this value expires to allow the controller to skip a defrost.
P-120	Disp Def Button	Allows to option to turn off the local defrost button (#) on the controller display.
P-80	Door alarm delay	Delay after the door open input is activated before the alarm occurs.
P-81	Door Closes Valve	This parameter is used to close the stepper valve if the door opens. If the door remains open then the valve will resume normal operation on the expiry of the door alarm delay (P-80).
P-82	Door Stops Fan	This parameter is used to stop the fans if the door opens. If the door remains open then the fans will resume normal operation on the expiry of the door alarm delay (P-80).
P-60	Lights Mode	Allows the user to set the lights mode: - <ul style="list-style-type: none"> ➤ Always off ➤ Always on ➤ Use a local schedule P-61 to P-74) ➤ Use a remote schedule (Set up in the system front end)
P-61	Sun Lights On	When P-60 is set to Local, Sunday on time
P-62	Sun Lights Off	When P-60 is set to Local, Sunday off time
P-63	Mon Lights On	When P-60 is set to Local, Monday on time
P-64	Mon Lights Off	When P-60 is set to Local, Monday off time
P-65	Tue Lights On	When P-60 is set to Local, Tuesday on time
P-66	Tue Lights Off	When P-60 is set to Local, Tuesday off time
P-67	Wed Lights On	When P-60 is set to Local, Wednesday on time
P-68	Wed Lights Off	When P-60 is set to Local, Wednesday off time
P-69	Thu Lights On	When P-60 is set to Local, Thursday on time
P-70	Thu Lights Off	When P-60 is set to Local, Thursday off time
P-71	Fri Lights On	When P-60 is set to Local, Friday on time
P-72	Fri Lights Off	When P-60 is set to Local, Friday off time
P-73	Sat Lights On	When P-60 is set to Local, Saturday on time
P-74	Sat Lights Off	When P-60 is set to Local, Saturday off time
P-30	Broadcast ID	ID of Plant Controller being used to broadcast Suction Pressure The Broadcast ID is derived from the Rotary Switch positions set on the Plant controller which is providing the remote suction pressure. Note: No two Plant controllers on a local area network can have the same rotary switches positions set. This will have adverse effects on control.



Please ensure all power is switched off before installing or maintaining this product.

P-31	Refrigerant	Type of refrigerant gas used in the system. See: Refrigerant Table above
P-110	Ref weight	When using a local pressure transducer or a transmitted pressure from a pack controller is used to calculate superheat, the Mercury controller can use a weighted average of liquid pressure and vapour pressure to calculate the temperature. When the refrigerant weight parameter is set to 0% then the liquid pressure is used (bubble), when set to 100% the vapour pressure is used (dew). For example, when the Ref Weight parameter is set to 50%, then the controller will use a weighted average of 50% liquid pressure and 50% vapour pressure. Any percentage from 1 to 99% will give an appropriate weighted average between the two pressures.
P-32	Pressure Units	Absolute or Gauge
P-33	Evap Offset	Offset to allow for pressure drop over distance
P-34	Glide	Allows a glide value to be applied for a particular refrigerant mix where the component gases have different boiling points (at the same pressure).
P-35	Trans Span	Total range of the transducer
P-36	Trans Offset	Value below zero
P-37	MOP Cut-in	If the pressure exceeds this value, then the controller's valve will close or be reduced to a predetermined percentage. A MOP alarm is also created. (See Maximum Operating Pressure (MOP)). If the controller is connected to a Mercury switch (PR0018-PHI) with a pressure transducer connected fitted then the MOP parameters are contained within the switch, MOP parameters in the Mercury controller do not apply.
P-38	MOP Diff	When the pressure reduces below this value, the controllers valve will recover to their normal operational
P-39	MOP Delay	Delay after the MOP value has been exceeded before the MOP actions and alarm occurs.
P-150	Custom A1	For more information regarding the setting up of custom refrigeration, please contact RDM Technical Support.
P-151	Custom B1 Hi	
P-152	Custom B1 Lo	
P-153	Custom C1	
P-154	Custom A2	
P-155	Custom B2 Hi	
P-156	Custom B2 Lo	
P-157	Custom C2	
P-120	Valve Type	Choose from four preconfigured stepper valve types or select "Other" to enter Stepper characteristics for a valve which is not listed. See Valve Type
P-121	Step Max	Number of steps controller will send to open valve to 100%. Consult the valve manufacturer to obtain the required number of steps. (Has no effect if Valve Type 0, 1, 2 or 3 selected at P-120). See Valve Type
P-122	Step Close	Number of steps controller will send to close valve fully to 0% and overdrive the valve. The Steps required when overdriving the valve can vary. Please consult the valve manufacturer to obtain the required number of steps (Has no effect if Valve Type 0, 1, 2 or 3 selected at P-120) See Valve Type
P-123	Step Speed	Increases and decreases the rate of step change. Enter a value in Hz. Valve Manufacturers specification must be followed. (Has no effect if Valve Type 0, 1, 2 or 3 selected at P-120) See Valve Type and Appendix 3 Step Speed .
P-124	mA Peak	Current requirement of motor. Care should be taken when setting this parameter as too high a setting could damage the valve motor. Valve Manufacturers specification must be followed. (Has no effect if Valve Type 0, 1, 2 or 3 selected at P-120) See Valve Type
P-125	Half Step*	Allows the stepper motor to be rotated in half step increments when used in conjunction with a half step compatible valve. The parameter has no effect if the Valve Type (P-120) is set to 0, 1, 2 or 3 (See Valve type). To allow for half stepping P-120 must be set to '4' (other). *Important: From Software V3.5 by selecting half step, the Step Max and Step Close parameters (P-121 & 122) will automatically be doubled. In versions prior to this these parameters should be set to double the normal values when Half Stepping is enabled. Note: When using a Carel E ² V valve with this controller it is advisable to use half stepping.
P-126	mA Hold	Current supplied to valve when it is stationary, to prevent any drift in valve position See: Holding Current
P-127	Shut Speed	This is the speed in Hz that the valve will shut at if the shut input (probe 7) becomes open circuit.



Please ensure all power is switched off before installing or maintaining this product.

P-128	Overdrive Time	This is the period in hours that the valve will close fully to allow the controller to re calibrate the valve position, this is required as there is no feedback to the controller from the valve in regards to it's position. See: Valve State – Overdriving
P-129	Shut Enable	Enables the shut input from the Intuitive Power Store, set to N/C. Will only work if valve type P-120 is set to "Other"
P-130	Shut Time	Once the shut input has been activated the valve will stay closed for this period even if the shut input is removed.01:00
dFLt	Restore default values	Restores all of the parameters to their default values

Holding Current

If using a type of valve that requires a holding current you must select "Other" at P-120 and make sure parameters P-121, P-122, P-123, P-124 and P-125 are all set to the correct values.

Warning: Not all valves require a holding current and applying a holding current to valves that do not require one could result in damage to the valve and/or controller. **Refer to Manufacturers Data Sheet for information on holding current.**

Half Step

Parameter P-125 allows the stepper motor to be rotated in half step increments when used in conjunction with a half step compatible valve. The parameter has no effect if the Valve Type (P-120) is set to 0, 1, 2 or 3 (See [Valve type](#)). To allow for half stepping P-120 must be set to '4' (other).

***Important:** From Software V3.5 by selecting half step, the Step Max and Step Close parameters (P-121 & 122) will **automatically** be doubled. In versions prior to this these parameters should be set to double the normal values when Half Stepping is enabled.

For example when using a Carel E²V valve, which requires half stepping to be enabled, although it is similar to the E³V Carel valve whereby "Step speed" and "mA Peak" match, P-120 (valve type) must be set to "Other" for half stepping to be used.

Note: When using a Carel E²V valve with this controller it is advisable to use half stepping.

Stepper Valve Type

Parameters P-121, P-122, P-123, P-124 and P-125 only have an effect if "Other" is selected when configuring parameter P-120. Other allows the user to map in the requirements the stepper valve.

Selecting option 0, 1, 2 or 3 at parameter P-120 sets the controller for use with the factory set values for the type of valve selected. The controller will override any values set in parameters P-121, P-122, P-123 and P-125. **Note** the parameters relating to the Stepper Valve type should be configured prior to wiring the Stepper Valve to the Mercury 2 Stepper controller. If one of the three default valve types is selected then changing P-121, P-122, P-123, P-124 and P-125 will have no effect.

Manufacturer	Model	Step Max	Step Close	Step Speed (Hz)*	mA Peak	mA Hold	Half Step	Overdrive (Hours)
Carel	E ³ V	480	500	50	450	0	Off	8
Sporlan 1	SER A/B/C/D	2500	3500	200	80	0	Off	24
Sporlan 2	SER 1.5 to 20, SEI 6	1596	1756	200	80	0	Off	24
Alco	EX4/5/6	750	825	500	500	0	Off	8
Other	Various	2500	3500	200	80	0	Off	8

See [Appendix 3 Step Speed](#) also.



Please ensure all power is switched off before installing or maintaining this product.

Valve Wiring

Manufacturer	Model	Wiring (Colours)	Connection Description (See Stepper Output)
Carel	E ³ V / E ² V	Yellow	M1B
		White	M1A
		Green	M2A
		Brown	M2B
Sporlan	SER 1.5 - 20 SER B/C/D SEI 6	Green	M1B
		Red	M1A
		White	M2A
		Black	M2B
Alco	EX4/EX5/EX6	White (A)	M1B
		Black (B)	M1A
		Blue I	M2A
		Brown (D)	M2B

Important – Our information is taken from 3rd party data sheets at the time our document is created, any changes since will not be incorporated in our document. Review the manufacturer's datasheet for the selected valve before installation. If you are unsure regarding any of the above steps please contact RDM Technical Support for further assistance.

Valve State – Overdriving

Each time the controller is powered on the control valve state has to initialise as the controller will have no knowledge of the current valve opening position for the stepper motor attached. During this process the controller will close the valve by a number of steps greater than the total number of steps for the valve configured. This is achieved using the Step Close parameter and is referred to as "overdriving" the valve. This process will synchronize the controller with the stepper valve output. This ensures the stepper valve is at the 0 steps position, fully closed and the control algorithm will use this for future control operations. The overdrive parameter (P-128) will overdrive the Stepper motor output by 10% of the step max value at the pre-set period (24 hours for example), this provides an automatic re-synchronisation of the valve position.

Please consult the stepper valve manufacturer's data sheet to obtain the number of steps required to overdrive the valve.

Stepper Valve Control Using Pressure

There are several ways to use the suction pressure to calculate the evaporator in temperature.

Direct Transducer Connection

(P-17 set to Trans V or Trans mA) A suction transducer can be connected directly to the controller, the controller will calculate the evaporator temperature from the suction pressure, and along with the suction temperature probe local to the controller, the superheat is calculated. Please note that RDM recommend that the evaporator in temperature probe is fitted as the controller will use this to calculate the superheat in the event of a transducer fault

(Parameters P58/59/75/76/84/91/99) will need to be set accordingly

Mercury Switch (PR0018-PHI)

(P-17 set to Rem1) The Mercury Switch can be used for superheat control on an island by island basis. In the application the evaporator in temperature probe reading for a case controller can be obtained from the Mercury switch on which the controller is connected. A suction pressure transducer is connected from the case Island to the 4-20mA input of the Mercury Switch and the pressure read from this transducer is converted to a temperature based on the gas type being used by the system. This temperature is transmitted to each controller connected to the switch and, along with the suction temperature probe local to the controller, the superheat is calculated. Please note that RDM recommend that the evaporator in temperature probe is fitted as the controller will use this to calculate the superheat in the event of a communication loss with the Mercury Switch. (P-17) allows for the use of this remote temperature provided by the Mercury Switch. Please see the Mercury Switch user document (PR0018-PHI) for further details.



Please ensure all power is switched off before installing or maintaining this product.

Remote pressure Direct from a Plant Pack Controller

Using IP Module

(P-17 set to Rem1, Rem2 or Rem3 depending on which input the suction transducer is connected to on the plant controller, transducer input 1, 2 or 3). Set the broadcast ID (P-58) to the ID of Plant Pack Controller (Rotary Switch Setting), (P-59) set to refrigerant type, (P-75) set to pressure units absolute or gauge

Maximum Operating Pressure (MOP)

The Mercury controller can calculate it's superheat using a pressure value. This pressure value can be obtained in 3 different ways: transmitted from an RDM pack controller, from a pressure transducer fitted to a local Mercury Switch or a pressure transducer connected directly to the Mercury controller (via an appropriate daughter card). If the MOP cut-in value is exceeded then the stepper valve opening is reduced by the "Div Value" parameter and an MOP alarm generated. For example if the "Div Value" parameter is set to 50% and the MOP alarm is generated then the maximum valve opening will be limited to 50%.

Ref Weighting

When using a local pressure transducer to calculate superheat, the Mercury controller can use a weighted average of liquid pressure and vapour pressure to calculate the temperature. For example, when the Ref Weight parameter is set to 50%, then the controller will use a weighted average of 50% liquid pressure and 50% vapour pressure. Any percentage from 1 to 99% will give an appropriate weighted average between the two pressures.

Relay State and functional operation

Relay State	Function State	Wired contact	Relay State	Function State	Wired contact
Relay 1 off	Fans on	N/C	Relay 3 off	LLV = Open	N/C
Relay 1 on	Fans off	N/C	Relay 3 on	LLV = Closed	N/C
Relay 2 off	Lights on	N/C	Relay 4 off	Alarm Relay = Alarm	N/C
Relay 2 on	Lights off	N/C	Relay 4 on	Alarm Relay = OK	N/C
Relay 3 off	Suction or Trims off	N/C	Relay 4 off	Defrost Control off	N/O
Relay 3 on	Suction or Trims on	N/C	Relay 4 on	Defrost Control on	N/O
Relay 3 off	Alarm Relay = Alarm	N/C			
Relay 3 on	Alarm Relay = OK	N/C			

Relay and screen states during defrost

State:	Pump Down	Defrost Min	Defrost Max	Drain Down	Fan Delay	Recovery
Screen:	DEF	DEF	DEF	DEF	DEF	REC
Def LED:	On	On	On	Off	Off	Off
Stepper Valve	Closed	Closed	Closed	Closed	Open	Open
RLY 1 Fans (On in DF)	On	On	On	On	Off	On
RLY 1 Fans (Off in DF)	On	Off	Off	Off	Off	On
RLY 2 Lights relay	On	On	On	On	On	On
RLY 3 Suction Line	Off	On	On	On	Off	Off
RLY 3 Trim on in defrost	On	On	On	On	On	On
RLY 3 Trim off in defrost	Off	Off	Off	Off	Off	On
RLY 3 Suction LLV	Off	Off	Off	Off	On	On
RLY 4 Defrost Relay	Off	On	On	Off	Off	Off

Defrost Termination

Defrost termination will be when the temperature parameter "def terminate" has been reached on the "defrost termination" probe. If the "defrost termination" probe is not fitted, defrost termination will occur when: -

- The "coil in" probe reaches the set point (If fans are selected as "off during defrost")
 Or The "air off" probe reaches the set point (If fans are selected as "on during defrost")

If the "coil in" probe is not fitted, the "air off" probe will be used. If the "air off" probe is faulty termination will occur when the time-out period has elapsed.



Please ensure all power is switched off before installing or maintaining this product.

Fan Delay after Defrost

The fans will come back on when: -

- The fan delay time has elapsed if the "fan delay mode" is set to time
- Or If the fan delay mode is set to "temp", the fans will come on when the defrost termination probe reaches the fan delay set point, or on the time parameter, whichever occurs first.

If the "defrost termination" probe is not fitted, the fans will come on when: -

- The "coil in" probe reaches the control set point (If fans are selected as "off during defrost")
- Or The "air off" probe reaches the control set point (If fans are selected as "on during defrost")

Network Configuration – RS232 comms

The final section to setup is the network address. In all instances, this must be done before the controller is connected to the site network.

When logging a Mercury 3 with an RS232 interface onto a network you must first connect the controller to a communications module, this is either a 485 Legacy, IP Futura, Mercury Switch or Wireless Mesh Interface. For Mercury 3's with the IP interface please refer to the [Network Configuration – IP comms](#) section for details of networking.

RS485 Legacy module

Using RS485, the controllers have an auto-initialise function, which will automatically log the device onto the site network. If the wrong address has been entered onto the network, you will have to reset the controller address by setting the address to 00-0, and then re-enter the correct address (you may have to deregister the wrong address from the home system as well).

Connecting an RS485 legacy Module to the controller will govern which set-up screens are made available in the 'Net' menu. The module will support the "Genus" protocol only. Using RS485 will show the below;

Display	Option
485t	485 Network Type
485A	485 Address/ Name
gAdd	Show underlying network address assigned to controller
rLog	Re-log the controller back onto the network
ClrA	Clear the address/name from the controller
ESC	Exit network menu. N.B. this option must be selected to save any changes made in this menu

The **485t** option shows a value representing the network type. The possible values are:

Value	Network Type
1	Genus compatible (all versions)
2	RDM Wireless Mesh System (Wireless Mesh)

Ensure option '1' is selected (for RS485).

The **485A** option shows a value representing the name of the controller in a Genus compatible network. For example, if the value shown in 485A is shown as "05-6". The controller would try to log onto a Genus compatible network using the name 'RC05-6'.

The **gAdd** option displays (in hexadecimal format) the underlying network address assigned to the controller when it was logged onto the network. Note: this is automatically assigned by the Data Manager.

The **rLog** option allows the controller to be logged back onto the network with its current name. The 'rLog' message will flash, waiting for confirmation. To confirm, press the Enter button to execute the command, Up or Down buttons to cancel.

The **ClrA** option will clear out the network address and name in the controller. The 'ClrA' message will flash for confirmation. Press the Enter button to execute the command, Up or Down buttons to cancel.



Please ensure all power is switched off before installing or maintaining this product.

Fast Network Address Reset

To enter this mode, hold the Enter, Up and Down buttons together for approximately 3 seconds until the message ClrA appears on the display. ClrA is the first option in the menu consisting of the following options:

Display	Option
ClrA	Clear the address/name from the controller
ESC	Exit Setup mode

Pressing the Enter button to select the ClrA option will cause the 'ClrA' message to flash for confirmation, if the network type is set to Genus compatible. Press the Enter button to execute the command, Up or Down buttons to cancel. If the network type is not set to Genus compatible then the ClrA message will not flash and the ESC option can be used to exit the menu.

IP Futura module

In an IP system there are two options;

- IP-L
- IP-r

IP-L allows you to fix a static IP address into the controller, which you would use when you are connecting the controllers onto a customer's local area network. This would allow the customer to view each controller using a generic Internet browser.

IP-r allows you to give each controller on the system a unique number (using the rotary switches). This number is then allocated a dynamic IP address by the system's DHCP server (such as the RDM Data Manager).

IP-L

To configure the communication module, set all three rotary switches to zero. The module should then be connected to the controller.

- From the function menu you can now select 'nEt'.
- Press enter and the display will show "IP-L", press enter once more.
- You can now set the IP network settings by using the table below

Display	Option
IP-1	IP Address byte 1
IP-2	IP Address byte 2
IP-3	IP Address byte 3
IP-4	IP Address byte 4
nL	Network Mask Length (see table below)
gt-1	Gateway Address byte 1
gt-2	Gateway Address byte 2
gt-3	Gateway Address byte 3
gt-4	Gateway Address byte 4
ESC	Exit network menu. N.B. this option must be selected to save any changes made in this menu

IP-r

To configure the communication module for IP-r, set the three rotary switches to give each controller a unique identifier. The module should then be connected to the controller and the network. The controller should then be powered on to connect to the network.

- From the function menu you can now select 'nEt'
- Press enter and the display will show "IP-r", press enter once more.
- You can now view (only) the address given by the DHCP server



Please ensure all power is switched off before installing or maintaining this product.

Network Mask Length

To ease setup, a single network mask length value is used. If the address has been specified with a network mask value in dotted IP format e.g. 255.255.255.0 then the table below gives the conversion:

Mask	Length	Mask	Length	Mask	Length
		255.255.254.0	23	255.254.0.0	15
255.255.255.252	30	255.255.252.0	22	255.252.0.0	14
255.255.255.248	29	255.255.248.0	21	255.248.0.0	13
255.255.255.240	28	255.255.240.0	20	255.240.0.0	12
255.255.255.224	27	255.255.224.0	19	255.224.0.0	11
255.255.255.192	26	255.255.192.0	18	255.192.0.0	10
255.255.255.128	25	255.255.128.0	17	255.128.0.0	09
255.255.255.0	24	255.255.0.0	16	255.0.0.0	08

Mercury Switch

The method of logging on the Mercury 3 (RS232 comms) will be similar to that of the IP Futura however please refer to the Mercury Switch user guide, which can be obtained from the RDM website, for information regarding connecting a controller to a network.

Network Configuration – IP comms

Mercury 3 controllers with the IP interface as standard does not require any communications module and will already communicate on the IP network protocol. When networking the Ethernet variant, the 'Net' menu will have the following menus;

Display	Option
IP-L / IP-r	Read/ Write Static IP address / Read Only DHCP IP address
Id	The 3 digit network address
AtyP	IP-r / IP-L selection
ESC	Exit Menu

Similar to the IP Futura / switch setup IP-L allows you to fix a static IP address into the controller and IP-r allows you to give each controller on the system a unique network number (using the Id).

- To firstly select between IP-L and IP-r navigate to 'AtyP'.

IP-r

Once IP-r is selected the controller must be given a unique 3 digit 'network address' that no other device on the network has (note if logging on to a Data Manager, this will be the device ID). Once the ID has been set connect the controller to the IP network for it then to be given an IP address by the DHCP server. To view the IP address given, within the Net menu, navigate to 'IP-r'.

IP-L

If IP-L has been selected from the 'AtyP' menu the IP address must be given to the controller by navigating to 'IP-L' within 'Net'. The following menu will be available;

Display	Option
IP-1	IP Address byte 1
IP-2	IP Address byte 2
IP-3	IP Address byte 3
IP-4	IP Address byte 4
nL	Network Mask Length (see the network mask length table above)
gt-1	Gateway Address byte 1
gt-2	Gateway Address byte 2
gt-3	Gateway Address byte 3
gt-4	Gateway Address byte 4
ESC	Exit network menu. N.B. this option must be selected to save any changes made in this menu

Once the IP address has been entered, the controller can be connected to the IP network.



Please ensure all power is switched off before installing or maintaining this product.

Viewing IO

Apart from setting up the controller, you can also view the status of the inputs and outputs and controller states. From the function menu, select "I/O", press enter. You can now scroll through the IO table as set out below. Inputs and outputs that do not apply to a particular controller type will be greyed out.

Input / Output Table

Number	IO	Range* °C (°F)	Step	Units	Case	Coldroom
I-01	Control Temp.	-42 to 60 (-43.6 to 140)	0.1	Deg	✓	✓
I-02	Display temp	-42 to 60 (-43.6 to 140)	0.1	Deg	✓	✓
I-03	Air on Probe	-42 to 60 (-43.6 to 140)	0.1	Deg	✓	✓
I-04	Air off Probe	-42 to 60 (-43.6 to 140)	0.1	Deg	✓	✓
I-05	Evaporator Probe	-49 to 60 (-56.2 to 140)	0.1	Deg	✓	✓
I-06	Suction Line Probe	-49 to 60 (-56.2 to 140)	0.1	Deg	✓	✓
I-07	Superheat	-30 to 60 (-54 to 108)	0.1	Deg	✓	✓
I-08	Logging Probe	-49 to 60 (-56.2 to 140)	0.1	Deg	✓	✓
I-09	Defrost Probe	-49 to 60 (-56.2 to 140)	0.1	Deg	✓	✓
I-10	Alarm Temp	-49 to 60 (-56.2 to 140)	0.1	Deg	✓	✓
I-11	Case Clean	0 (Off), 1 (On)			✓	✓
I-12	Door Sensor	0 (Closed), 1 (Open)				✓
I-13	Person Trapped	0 (OK), 1 (Alarm)				✓
I-14	External Defrost	0 (Off), 1 (On)			✓	✓
I-15	Monitor Probe	-49 to 60 (-56.2 to 140)	0.1	Deg	✓	✓
I-16	Remote Evaporator Temp	-49 to 60 (-56.2 to 140)	0.1	Deg	✓	✓
I-17	MOP	0 (Off), 1 (On)			✓	✓
I-18	Hub Trim Level	0 to 100	1.0	%	✓	
I-19	Divide Input	0 to 100	1.0	%	✓	✓
I-20	Remote Pressure	-3.4 to 100.0	0.1	Bar	✓	✓
I-21	Local Pressure	-3.4 to 100.0	0.1	Bar	✓	✓
I-22	Local Calculated Temp.	-49 to 60 (-56.2 to 140)	0.1	Deg	✓	✓
I-25	Shut Input	0 (Off), 1 (On)			✓	
O-01	Liquid Line Valve	0 (Open), 1 (Closed)			✓	✓
O-02	Suction Line / Trims	0 (Open), 1 (Closed)			✓	✓
O-05	Defrost Control	0 (Off), 1 (On)			✓	✓
O-06	Lights	0 (Off), 1 (On)			✓	✓
O-07	Case Fans	0 (Off), 1 (On)			✓	✓
O-09	Valve Opening	0 to 100	0.1	%	✓	✓
O-10	Last Def. Time	00:00 to 23:59		hh:mm	✓	✓
O-11	Last Def. Length	00:00 to 03:00		hh:mm	✓	✓
O-12	Last Def. Ctrl Temp.	-49 to 60 (-56.2 to 140)	0.1	Deg	✓	✓
O-13	Last Def. Type	0 (None), 1 (Internal), 2 (External), 3 (Network), 4 (Display), 5 (Timed) 6 (Forced), 7 (Skipped)			✓	✓
O-15	Alarm 1 Relay	0 (Unused), 1 (OK), 2 (Alarm)			✓	✓
O-16	Alarm 2 Relay	0 (Unused), 1 (OK), 2 (Alarm)			✓	✓
O-17	Remote Relay	0 (Off), 1 (On)			✓	✓
O-18	Run Time	0 – 128 K Hours	1		✓	✓
O-19	Valve Step	0-6400	1		✓	✓
O-20	Door Open Time	00:00 to 23:59		hh:mm		✓
O-21	Door Open Length	00:00 to 03:00		hh:mm		✓
O-30	Set Point Offset	-49 to 60 (-56.2 to 140)	0.1	Deg.	✓	✓
O-31	Trim Off Period	00:00 to 05:00	00:01	mm:ss	✓	



Please ensure all power is switched off before installing or maintaining this product.

S-01	Control State	0 (Stabilise), 1 (Normal), 2 (Defrost Min), 3 (Defrost Max), 4 (Drain Down), 5 (Fan Delay), 6 (Recovery), 7 (OT Alarm), 8 (UT Alarm), 9 (Fans Only), 10 (Lights Only), 11 (Case Off), 12 (Pump Down), 13 (Defrost Hold), 14 (Shut)			✓	✓
S-02	Valve State	0 (Off), 1 (Start), 2 (Run), 3 (Problem), 4 (Fail), 5 (Initial)			✓	✓

* Range is dependent on probe type

Display Messages

The following alarms and messages can appear on the Mercury display.

Display Message	System status	Display Message	System status
Ft	Control Fault	Plt3	Plant Fault 3
Prb1	Probe 1 Fault	Plt4	Plant Fault 4
Prb2	Probe 2 Fault	FanS ONLY	Controller in Fans Only
Prb3	Probe 3 Fault	LitS ONLY	Controller in Lights Only
Prb4	Probe 4 Fault	CASE OFF	Controller in Case Off
Prb5	Probe 5 Fault	Ot	Over Temperature Alarm
Prb6	Probe 6 Fault	Ut	Under Temperature Alarm
rEC	Control State in Recovery	door	Door Open Alarm
dEF	Control State in Defrost	TrAP	Person Trapped Alarm
AL	Control State in Alarm	LgOt	Log Probe Over Temperature
Plt1	Plant fault 1	LgUt	Log Probe Under Temperature
Plt2	Plant Fault 2		

Network Alarms

The table below shows the text and associated type number that is sent to the system "front end". The type number is normally used to provide different alarm actions.

Alarm text	Type # (index)	Alarm text	Type # (index)
Missed defrost	15	Product under temperature	9
Plant Fault 1,2,3 or 4	3	Person Trapped	1
Case over temperature	4	Monitor Probe OT	12
Case under temperature	5	Case Clean	29
Probe 1,2,3,4,5 or 6 Faulty	6	Remote evap temperature	6
Door Left Open	2	Transducer Fault	6
Product over temperature	8	Load Shedding	7
MOP Alarm	3	Lights Only	29
Valve Shut	2	Stepper Fault	3



Please ensure all power is switched off before installing or maintaining this product.

Modifying controller states

During normal operation you can change the following states from the function menu

Fans Only "FanS"

Selecting the Fans Only option will put the controller into the Fans Only state if the current state is not Fans Only. If the current state is Fans Only then the controller will change to the Normal state. Selecting this option will exit the setup menu automatically. The display will show "FanS OnLy"

If a remote display with key switch is being used, this function can be invoked by turning the key switch to the fans only position (90 degrees clockwise) with parameter P85 set to "fans"

Case Off "CASE"

Selecting the Case Off option will put the controller into the Case Off state if the current state is not Case Off. If the current state is Case Off then the controller will change to the Normal state. Selecting this option will exit the setup menu automatically. The display will show "CASE OFF". An alarm is generated, fixed delay of 1 minute, when the controller is placed into the Case Off state.

If a remote display with key switch is being used, this function can be invoked by turning the key switch to the case-off position. (Clockwise 90 degrees) with parameter P85 set to "case".

Lights Only "Ligt"

Selecting the Lights Only option will put the controller into the Lights Only state if the current state is not Lights Only. If the current state is Lights Only then the controller will change to the Normal state. Selecting this option will exit the setup menu automatically. The display will show "LitS OnLy". An alarm is generated, fixed delay of 1 minute, when the controller is placed into the Lights Only state.

Note. When lights are being used in "Remote" mode with a timing channel: -

If the controller goes offline, the lights are turned ON after a delay of 5 minutes. The lights will stay on until the controller comes back on-line where they will revert to the state of the timing channel being used.

Probe Offset

This feature allows each probe value to be modified by an "offset". Offset values are from -10°C (-18°F) to +10°C (+18°F) and on a channel basis. Example C1 = Probe 1.



Please ensure all power is switched off before installing or maintaining this product.

Remote Commands

The following commands can be used by a Data Builder program:

Command	Value to send	Description	Conditions
Defrost Command	1	Initiates a defrost cycle	Defrost mode: remote
Defrost Command	3	Terminates the defrost	Defrost mode: remote Defrost hold: On Defrost min state complete
Trim Command	0 to 100%	Sets the trim level to this value (Trim period is 5 min)	Relay 4 mode: Trim Heater
Setpoint Command	+/-18	Is added to or subtracted from the setpoint	
Case Off Command	5 8 0	Sets the controller to Case Off Sets the controller to Lights Only Restores the controller from Case Off to Normal	
Haccp Command	0 1 2	HACCP LED OFF HACCP LED On HACCP LED Flashes	
Button Command	0 1	Buttons backlights Off Buttons backlights On	
EEV Command	2 1	Shuts the valve off Restores the valve to normal operation	
Divider Command	0 to 100%	Sets the maximum valve opening to this percentage.	MOP input from Merc PHI hub must be 'Off'.

Use an "Analogue Out" block configured to the controller name and in the value field type in the command you require. Use a "Setting block" as the input to the "Analogue Out" block to send the Value.

See Example on the right, which sets the Trim Heater on BY10-1 at 40%.

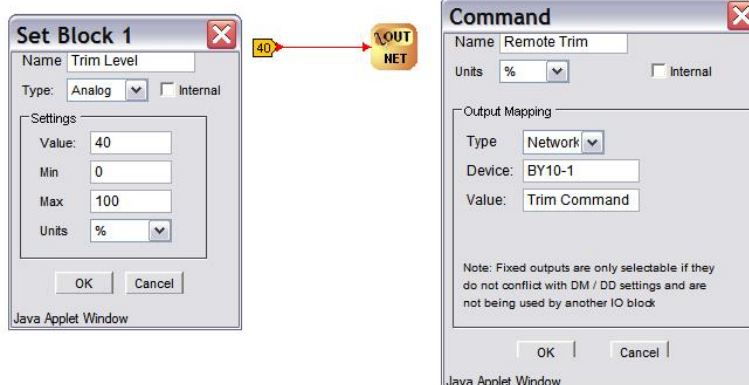

Please ensure all power is switched off before installing or maintaining this product.

Specification

Mercury Mk3 Controller PR0740 xxx STEP	
Power Requirements	
Supply Voltage Range	24 Vac or 24Vdc $\pm 10\%$ (DC only if using a power store PR0627)
Supply Frequency	50 – 60 Hz
Typical supply current	<1 Amp
General	
Operating temperature range	-10°C to 60°C (14°F to 140°F)
Storage temperature range	-20°C to 65°C (-4°F to 149°F)
Environmental	Indoor use at altitudes up to 2000m, pollution degree 2, installation category II. Voltage fluctuations not to exceed $\pm 10\%$ of nominal voltage.
Size	78mm (W) x 36mm (H) x 110mm (D)
Approx. Weight	177 grams
Safety	EN61010
EMC	EN61326:2013
Ventilation	There is no requirement for forced cooling ventilation
Class 2 Insulation	No protective Earth is required and none should be fitted
Supply Fuse	The host equipment must provide a suitable external over-current protection device such as: - Fuse: 2A Anti-surge (T) HRC conforming to IEC 60127
Or MCB	2A, Type C conforming to BS EN 60898
Connections	All relay and power connections are plug in with screw terminals, maximum 1.5mm ² CSA wire size (16 AWG 30pprox..).
Relay Specification	
Relays 1 – 3 Changeover, Shared Common	
Max current	6A Resistive (Cos ϕ = 1) 2A Inductive (Cos ϕ = 0.4)
Max voltage	250Vac, 30V dc
Relay 4 – Single Throw (normally open), Shared Common	
Max current	3A (non-inductive), COS ϕ =0.4 2A (inductive load)
Max voltage	250Vac
Mechanical Relay Operational Life	
Switching 3A load (non-inductive)	350,000 operations
Switching 500mA load (non-inductive)	2,000,000 operations
For compliance with the LVD, All relay commons must be at the same potential as the supply voltage	
Valve Output	
Bipolar Stepper Motor 24V 8W, Maximum current cannot exceed 825mA, Chopper Drive. Maximum settable peak current per motor coil 500mA.	
Inputs	
Probe Input resistance	3.01K Ohms (for PTC or NTC type probes)
Probe Input type	Selectable. See: Units
Transducer 0-10V	Connect a 0-10v signal
Transducer 4-20mA	4-20mA current loop, provides a 12 Vdc output to power the pressure transducer. See wiring
Digital Inputs	Volt Free
Comms	
Serial Variant	RS232 with flow control
Ethernet Variant	IP comms



Please ensure all power is switched off before installing or maintaining this product.

Switched Resistor Example Wiring

Example of resistor fitted on a probe input.

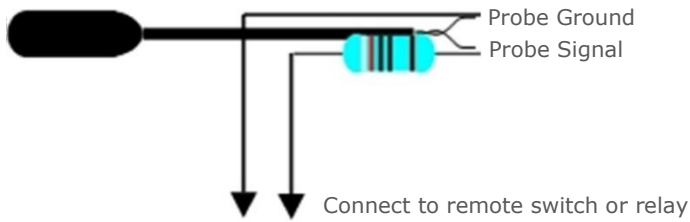

Installation & Dimensions

Panel Cut-out and Clearances

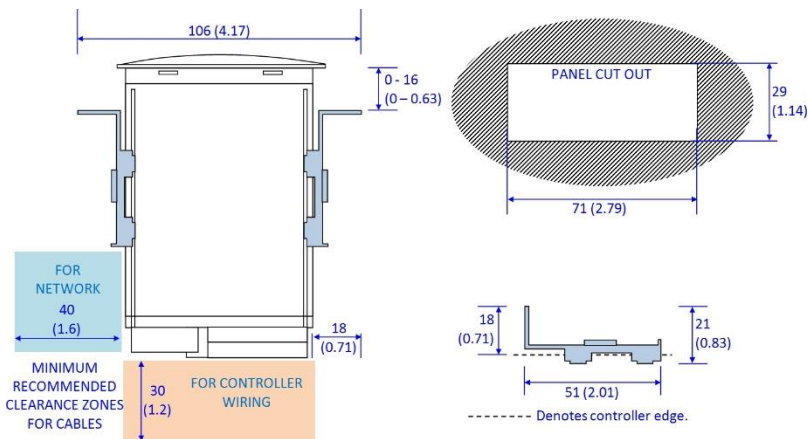

Fixing

The controller is fixed by sliding the 2 plastic retaining clips up to rear of the panel. These clips have a ratchet action and can be removed by holding in the clip sides and sliding back.

There is no requirement for forced cooling ventilation

Dimensions

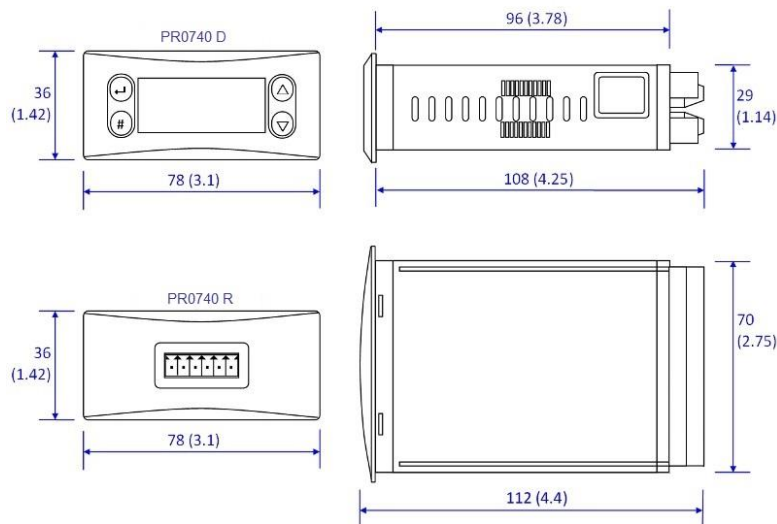

Cleaning

Do not wet the controller when cleaning. Clean the front by wiping with slightly dampened lint free cloth.



Please ensure all power is switched off before installing or maintaining this product.

Appendix 1: Defrost Cycles

Fans On in Defrost

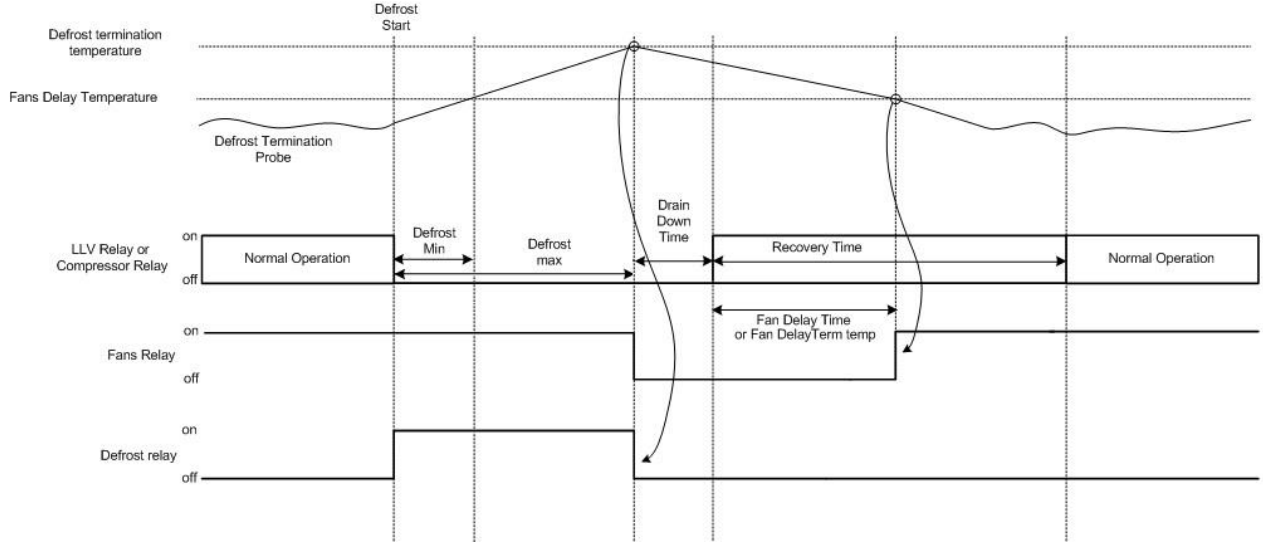

Fans Off in Defrost

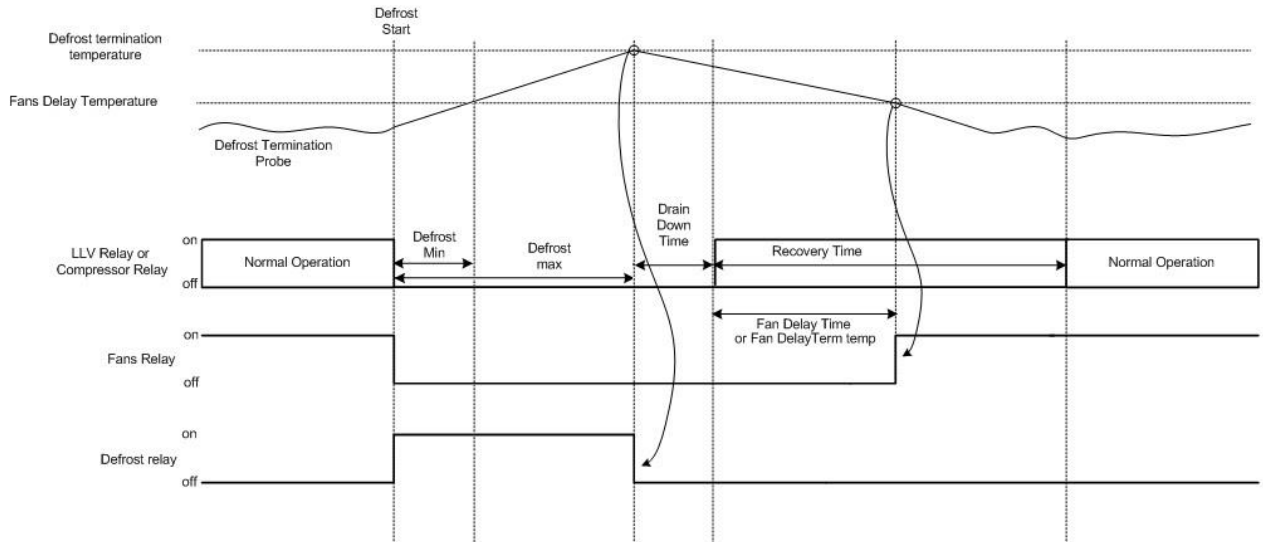

Please ensure all power is switched off before installing or maintaining this product.

Appendix 2: Trim Heater Control via Mercury/Intuitive Range

Energy savings via the RDM's range of case controllers can be achieved in a number of ways. One of which is pulsing the trim heater relay off for a given period of time. One way to pulse the trim heater is by configuring P-14. For greater energy savings the Data Manager Energy feature trim control or the Mercury Switch trim control feature can be used. These two options pulse the trim relay dependant on the actual shop floor humidity levels. Thus if the shop floor humidity is relatively low the trim heaters can be pulsed off for longer durations. Please see the relevant user guides for further details.

Due to the high switching rate, trim heaters must not be switched directly from the Mercury trim heater relay and a Trim Heater Pulse Module (PR0723) must be used in all instances of trim control. This module is fitted in between the trim heater of the case and the relay output of the Controller which is pulsing the heater. The trim heater module output provides a smoother power distribution, compared to using the relay output directly, as it switches at the zero voltage crossover point. Switching the trim heater on and off via a normal relay, without using the RDM trim heater pulse module, may damage the trim heater and reduce the operational life of the heater.

Please see the Trim Heater Pulse Module user guide for further details.

Appendix 3 Step Speed (Frequency Hz)

When setting the Step Speed, P-33, the following table applies.

Step Speed Entered	Actual Speed Set (Hz)	Step Speed Entered	Actual Speed Set (Hz)
500 and above	500	86 to 90	90
251 to 333	333	81 to 85	85
201 to 250	250	76 to 80	80
167 to 200	200	71 to 75	75
144 to 166	166	66 to 70	70
126 to 143	143	61 to 65	65
112 to 125	125	56 to 60	60
101 to 111	111	51 to 55	55
96 to 100	100	50 and below	50
91 to 95	95		

Please confirm with the Stepper valve manufacturer datasheets to select the correct step frequency.

Disclaimer

The specifications of the product detailed in this document may change without notice. RDM Ltd shall not be liable for errors or omissions, for incidental or consequential damages, directly or indirectly, in connection with the furnishing, performance or misuse of this product or document.

Revision History

Revision	Date	Changes
3.1	09/08/2018	Introduction of Mercury 3 Stepper
3.1a	08/10/2018	Duplicate parameter numbers P-100 & P-101 corrected in user guide.
3.1b	02/11/2018	Power store details updated.
3.1c	22/11/2018	Parameter table amended.
3.1d	29/11/2018	Parameter number P-05 corrected to P-128 in overdrive description.
3.1e	29/11/2018	I/O Table Updated, Appendix 3 added
3.1f	31/05/2019	I/O Table updated. Contact details updated.
3.3	20/08/2019	Support added for R454C and R455A. Ability to use a custom Refrigerant table added.
3.5	17/10/2019	Selecting Half Steps will automatically double the steps



Please ensure all power is switched off before installing or maintaining this product.

Group Offices

RDM Group Head Office

80 Johnstone Avenue
Hillington Industrial Estate
Glasgow
G52 4NZ
United Kingdom

+44 (0)141 810 2828
support@resourcedm.com

RDM USA

9441 Science Center Drive
New Hope
Minneapolis
MN 55428
United States

+1 612 354 3923
usasupport@resourcedm.com

RDM Asia

Sky Park at One City
Jalan USJ 25/1
47650 Subang Jaya
Selangor
Malaysia

+60 3 5022 3188
asiatech@resourcedm.com

Visit www.resourcedm.com/support for more information on RDM solutions, additional product documentation and software downloads.

While every effort is made to ensure the information given within this document is accurate, Resource Data Management Ltd shall not be liable for errors or omissions, for incidental or consequential damages, directly or indirectly, in connection with the furnishing, performance or misuse of this product or document. All specifications are subject to change without notice.

See www.resourcedm.com for terms and conditions of sales.

Copyright © Resource Data Management